

Granterra

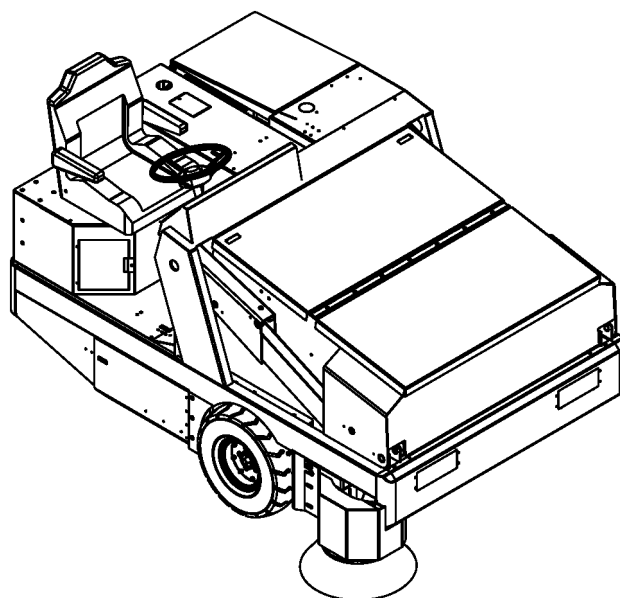

OPTIONS PARTS LIST

Models 56516904(Gas), 56516905(LPG), 56516906(Diesel)

Granterra

Item	Ref. No.	Qty	Description
			Factory Installed Option
*	0880-369	1	Safety Air Cleaner Option
*	0880-392	1	Back-Up Alarm Option
*	0780-683	1	Foam Filled Tire Option
*	0780-684	1	Soft Shoe HP Tire Option
*	0880-639	1	Fire Extinguisher Option
*	0880-351	1	Light Package Option (Head, Tail & Instrument)
*	0880-355	1	Light Package Option (Head, Tail, Brake, Instrument, Turn Signal & 4-Way Flasher)
*	0880-361	1	Curb Light Option NOTE 1
*	56516756	1	Overhead Guard Option
*	0880-406-1	1	Rotating Light Option
*	0880-359-1	1	Flashing Light Option
*	0880-408-1	1	Rotating Light Option (w/Overhead Guard)
*	0880-360-1	1	Flashing Light Option (w/Overhead Guard)
*	0880-391	1	Rear Work Light Option
*	56516865	1	Front Wheel Guards Option
*	0880-720	1	Retractable Seat Belt Option
*	56516764	1	Timed Filter Shaker Motors Option
*	56516861	1	Left Side Broom Option
*	56516765	1	Vacuum Wand Option
*	0880-353	1	Wet Sweep Bypass Option
*	0880-523	1	Clogged Filter Indicator Option
*	56516847	1	Four Corner Bumper Option
*	56516860	1	Stainless Steel Hopper Option
*	0780-694	1	Hopper High Temp Shutdown Option
*	56516867	1	SE Air Cleaner with Overhead Guard Option (Gasoline/LPG)
*	56100840	1	SE Air Cleaner with Overhead Guard Option (Diesel)
*	56516873	1	SE Air Cleaner with Amber Strobe Option (Gasoline/LPG)
*	56100841	1	SE Air Cleaner with Amber Strobe Option (Diesel)
*	56516881	1	Cab Option W/Pressurizer
*	0780-692	1	Cab A/C Option-Diesel
*	0880-762	1	Cab A/C Option-GM 3.0L
*	56516902	1	Cab Heater Option – Gasoline / Petrol
*	56516901	1	Cab Heater Option – LPG
*	56516900	1	Cab Heater Option – Diesel
*	0880-615	1	Cab Fan Option
*	0880-388	1	Cab Wiper Option
*	0880-616	1	Cab Dome Light Option

* = Optional, Not Included

NOTE 1: HEADLIGHTS REQUIRED TO ACCOMPANY THIS OPTION

DESCRIPTION	PAGE
Safety Air Cleaner Option.....	4
Broom Options	5
Back-up Alarm Option	6
Tire Options.....	7
Fire Extinguisher Option.....	8-9
Light Package Option – 0880-351	10-11
Light Package Option – 0880-355	12-13
Curb Light Option.....	14-15
Overhead Guard Option.....	16-17
Warning Light Options (W/O Overhead Guard)	18-19
Warning Light Options (W/ Overhead Guard).....	20-21
Rear Work Light Option.....	22
Front Wheel Guards Option	23
Retractable Seat Belt Option.....	24
Timed Shaker Filter Motors Option	25
Left Side Broom Option.....	26-27
Vacuum Wand Option	28-29
Wet Sweep Bypass Option	30-31
Clogged Filter Indicator Option	32-33
Four Corner Bumper Option.....	34-35
Stainless Steel Hopper Option.....	36
Hopper High Temperature Shutdown Option	37
SE Air Cleaner Option (with Overhead Guard)	38-39
SE Air Cleaner Option (with Amber Strobe Option).....	40-41
Cab Assembly	42-43
Cab Assembly w/Pressurizer	44-45
Cab A/C Option (Diesel).....	46-47
Cab A/C Option (GM 3.0 L).....	48-49
Cab Heater Option	50-51
Cab Fan Option.....	52
Cab Wiper Option.....	53
Cab Dome Light option	54

WHEN ORDERING PARTS

- * Use the part numbers from the "Ref. No." columns in this parts list.
- * Specify the model and serial number of the machine.
- * Use the space below to record the model and serial number for future reference.

Model _____ Serial No. _____

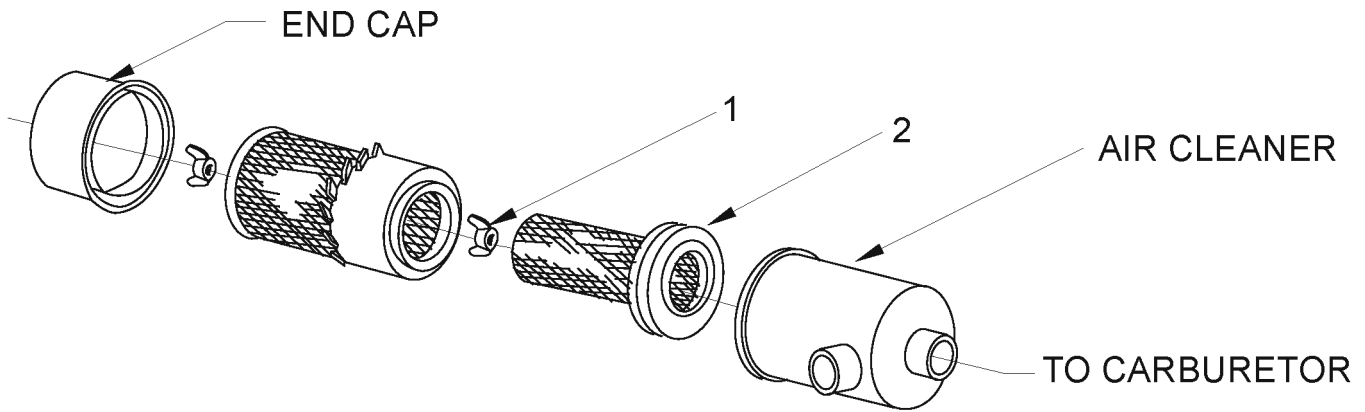

Item	Ref. No.	Qty	Description
	0880-369	1	Safety Air Cleaner Option
1	8-23-03064	1	Wing Nut Assembly
2	8-24-04111	1	Filter Element
3	8-24-04106	1	Filter Element

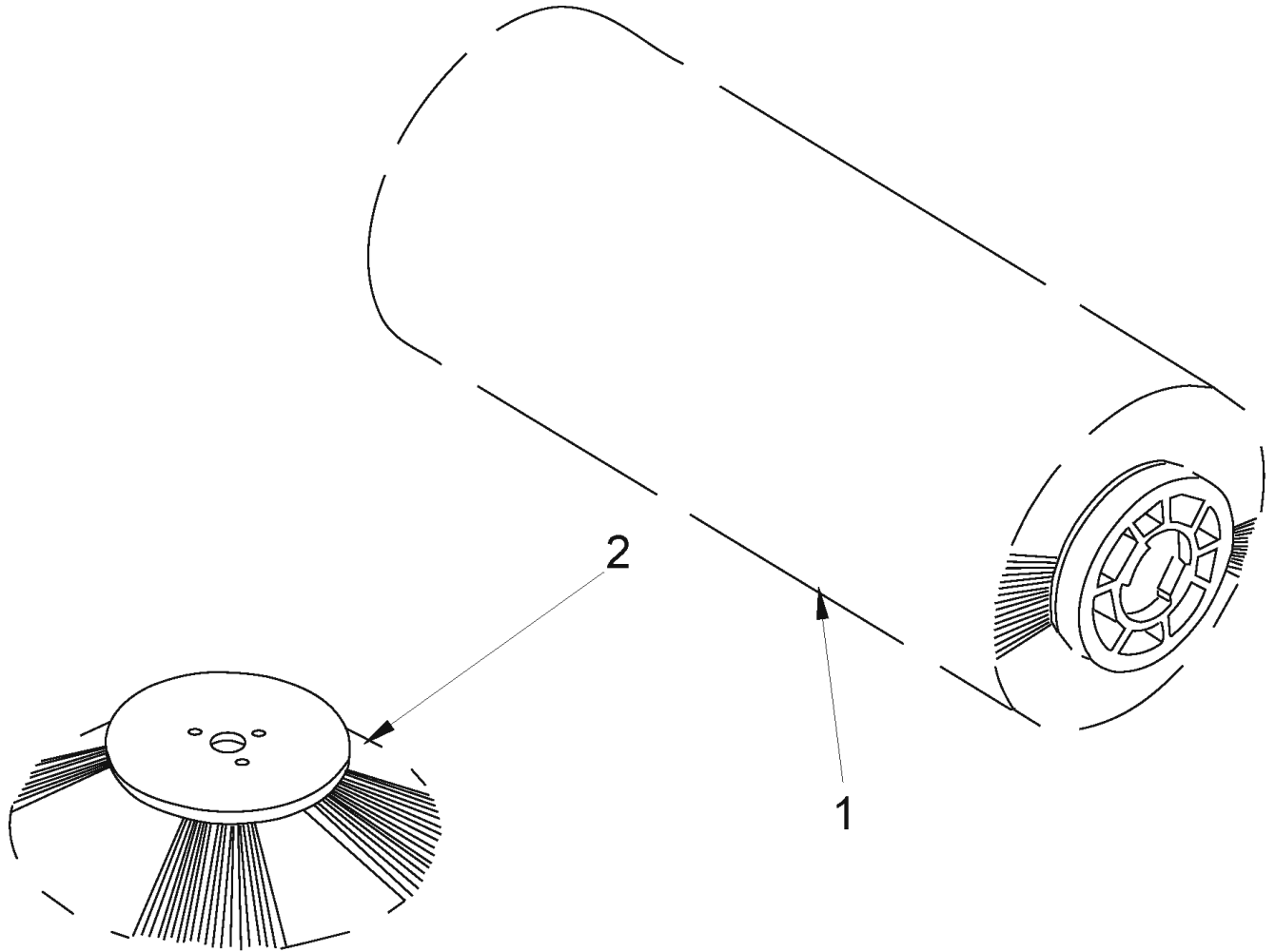

Item	Ref. No.	Qty	Description
1	8-08-03202	1	Proex and Wire
	8-08-03204	1	Proex
	8-08-03207	1	Nylon
	8-08-03209	1	Polypropylene
	8-08-03210	1	Fiber and Wire, High Density
	8-08-03214	1	Poly and Wire
	2	8-08-03212	1
8-08-03211		1	Nylon
0880-439		1	Wire Broom

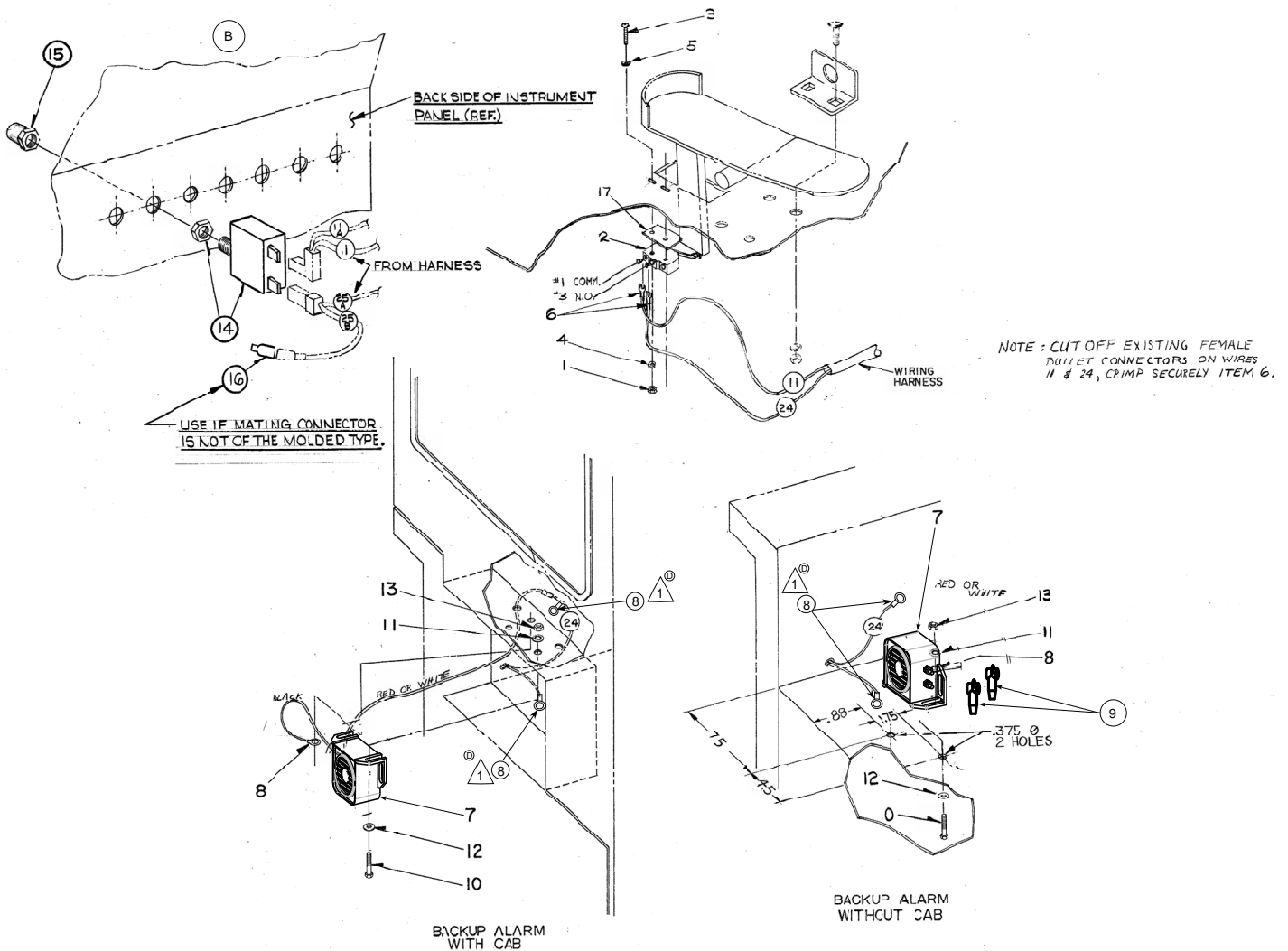

Item	Ref. No.	Qty	Description
	0880-392	1	Back-Up Alarm Option
1	2-00-00624	2	Nut, Hex MS #6-32 x .312 x .109
2	7-82-00009	1	Mechanical Switch
3	2-00-05060	2	Screw, #6-32 x 1.250 RHM
4	2-00-01499	2	Lock Washer, Helical Spring #6 Med
5	2-00-00455	2	Flat Washer, .375 x .156 x .046
6	2-00-04808	2	Terminal, #8 Screw
7	56409232	1	Backup Alarm
8	2-00-00828	1	Terminal
9	56409538	2	Insultaor-Terminal
10	2-00-00213	2	Screw, 5/16 - 18 x .625 HHC
11	2-00-02303	2	Lock Washer, 5/16 Int.
12	2-00-00409	2	Flat Washer, .687 x .343 x .062
13	2-00-00585	2	Nut, Hex 5/16 - 18 x .500 x .265
14	8-64-00008	1	Circuit Breaker
15	8-11-00044	1	Boot
16	8-11-00015	1	Terminal
17	7-35-00013	1	Insulation

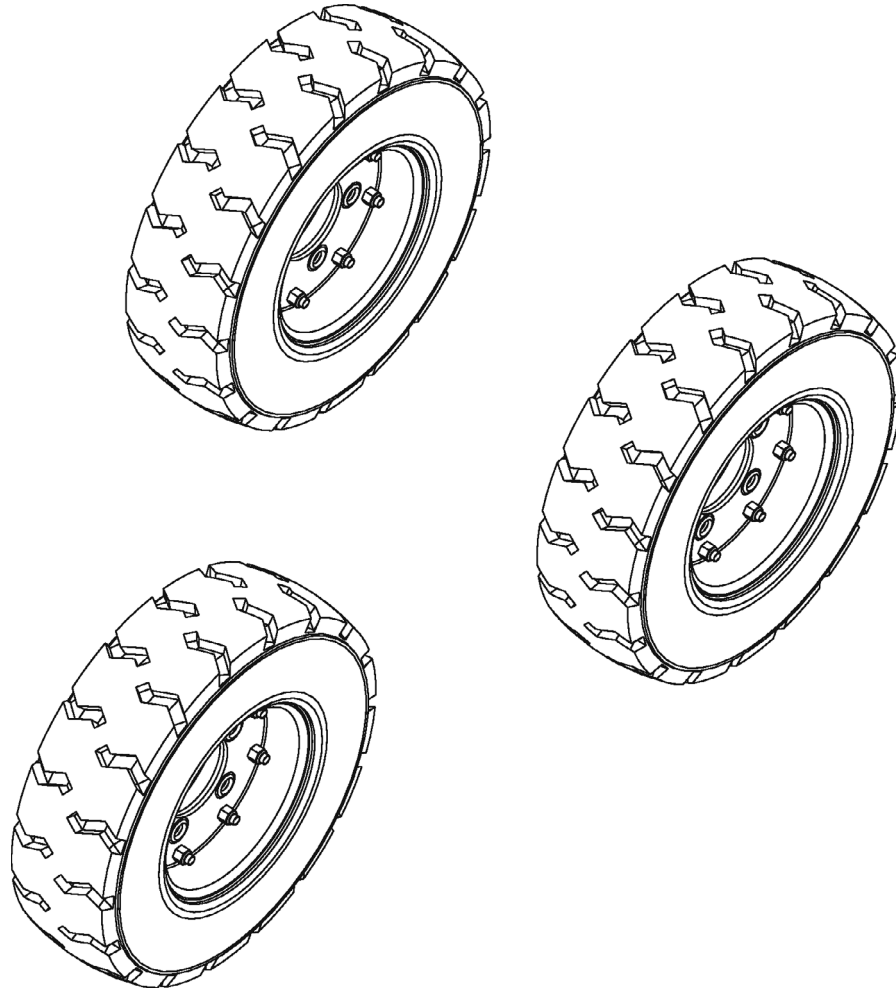

Item	Ref. No.	Qty	Description
	0780-683	1	Foam Filled Tire Option
1	7-89-08273	1	Wheel Assy. - Pneumatic Foam-Fill - Rear
2	8-89-08056	2	Wheel Assy. - Pneumatic Foam-Fill - Front

Item	Ref. No.	Qty	Description
	0780-684	1	Soft Shoe HP Tire Option
1	8-89-08060	1	Solid Pneumatic Soft Shoe Lug Tread - Rear
2	8-89-08055	2	Solid Pneumatic Soft Shoe Lug Tread - Front

Service Parts

Rim Assy.	8-65-05016(front)
Tire Only	8-85-06019 (front & rear)

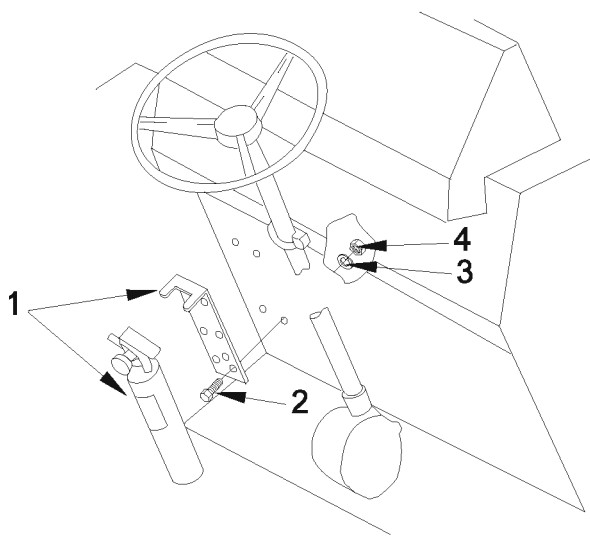

FIRE EXTINGUISHER
IN DRIVER COMPARTMENT

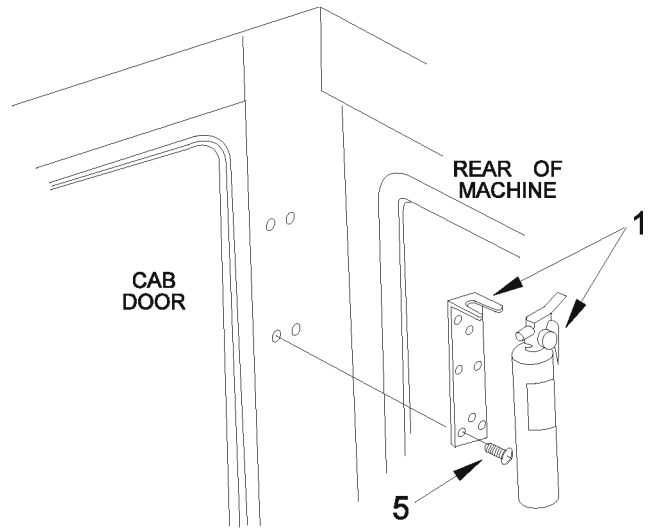

FIRE EXTINGUISHER
IN CAB

09-5

FIRE EXTINGUISHER OPTION

Granterra

9

Item	Ref. No.	Qty	Description
	0880-639	1	Fire Extinguisher Option
1	8-83-04033	1	Fire Extinguisher
2	2-00-00221	4	Screw, 1/4 - 20 x .750 HHC
3	2-00-00518	4	Lock Washer, Helical Spring 1/4 Med
4	2-00-00594	4	Nut, Hex MS 1/4 - 20 x .437 x .187
5	2-95-01998	4	Screw, #1/4 - 10 x .750 T/F RH

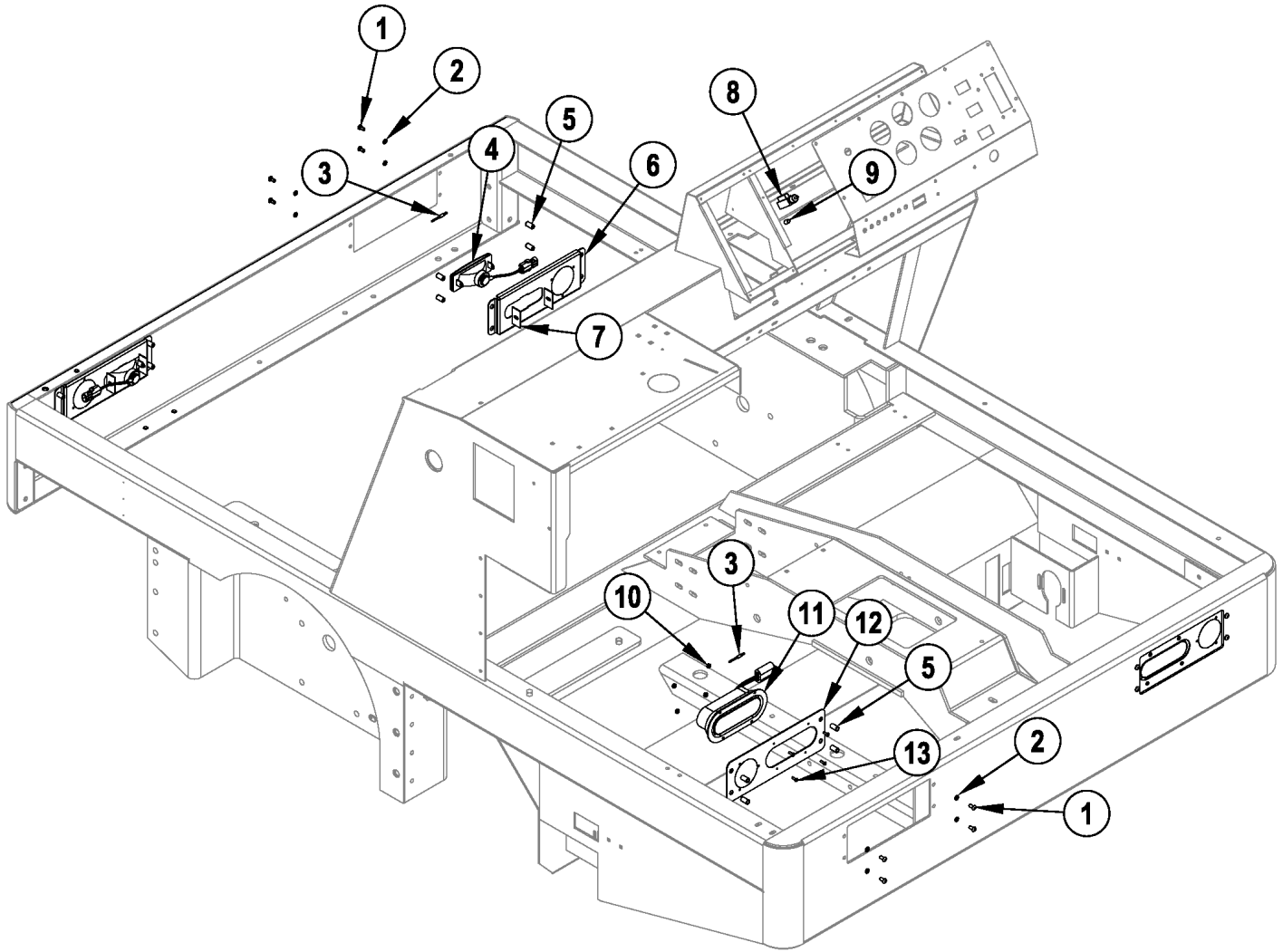

Item	Ref. No.	Qty	Description
	0880-351	1	Light Package Option
1	2-00-04876	16	Screw, 1/4-20 x .50 RHS Nylok
2	2-00-00501	16	Washer, 1/4 Int. Lock
3	2-00-04578	4	Terminal-Male Bullet
4	7-40-05046	1	Headlight-1 Pair 12v-55w
5	2-00-05261	16	Threaded Insert-1/4-20
6	56514886	2	Bracket-Front Light
7	7-08-01174	4	Bracket-Headlight Mount
8	8-82-00027	1	Switch-Push/Pull Light
9	2-00-04588	1	Wire Nut
10	56003309	8	Nut-Hex Nyl Loc-Thin SS 8-32
11	7-40-05047	2	Light-Tail/Brake/Turn-Red
12	56514885	2	Bracket-Rear Light
13	56002876	8	Scr-Pan Phil SS 8-32 x .50
[]	8-40-05030	3	Light, Instrument
[]	8-90-07358	4	Wire (Ground for Lights)

[] = Not Shown

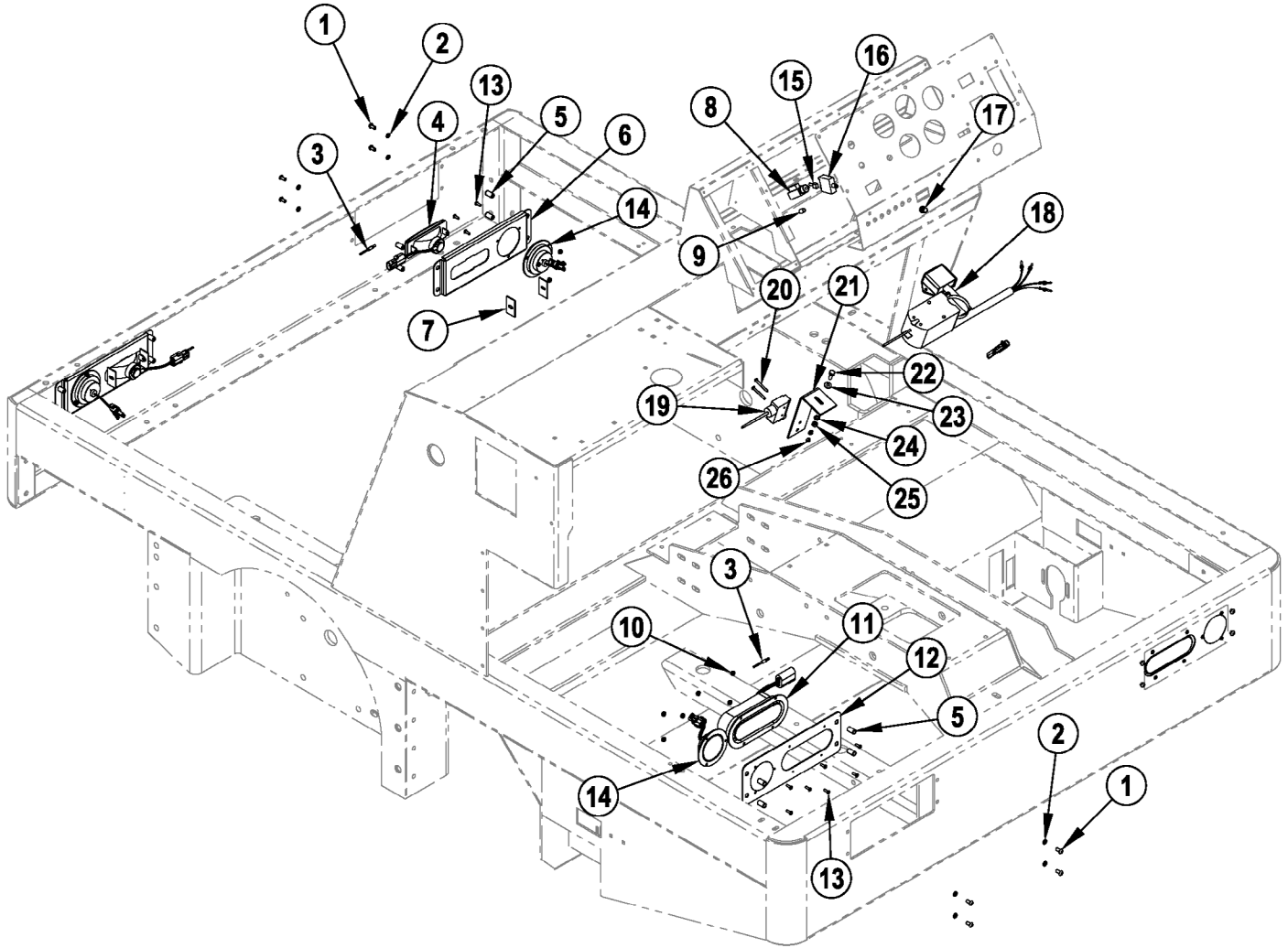

Item	Ref. No.	Qty	Description
	0880-355	1	Light Package Option
1	2-00-04876	16	Screw, 1/4-20 x .50 RHS Nylok
2	2-00-00501	16	Washer, 1/4 Int. Lock
3	2-00-04578	4	Terminal-Male Bullet
4	7-40-05046	1	Headlight-1 Pair 12v-55w
5	2-00-05261	16	Threaded Insert-1/4-20
6	56514886	2	Bracket-Front Light
7	7-08-01174	4	Bracket-Headlight Mount
8	8-82-00027	1	Switch-Push/Pull Light
9	2-00-04588	1	Wire Nut
10	56003309	20	Nut-Hex Nyl Loc-Thin SS 8-32
11	7-40-05047	2	Light-Tail/Brake/Turn-Red
12	56514885	2	Bracket-Rear Light
13	56002876	20	Scr-Pan Phil SS 8-32 x .50
14	7-40-05048	4	Light, Side Marker (Amber)
15	8-11-00015	1	Terminal
16	8-64-00008	1	Circuit Breaker (15 amp)
17	8-11-00044	1	Boot
18	8-82-00025	1	Switch, Turn Signal
19	8-82-00058	1	Switch, Brake
20	2-00-00090	2	Screw, #8-32 x 1.50 RH
21	8-08-00865	1	Bracket, Brake Switch Mount
22	2-00-00221	1	Screw, 1/4-20 x .75 HHM
23	2-00-03702	1	Flat Washer, 1/4
24	2-00-00518	1	Lock Washer, 1/4 Helical Spring
25	2-00-00594	1	Nut, 1/4-20 Hex
26	2-00-01372	2	Nut, #8-32 Hex
[]	8-40-05030	3	Light, Instrument
[]	8-90-07358	4	Wire (Ground for Lights)
[]	7-90-07229	1	Wire

[] = Not Shown

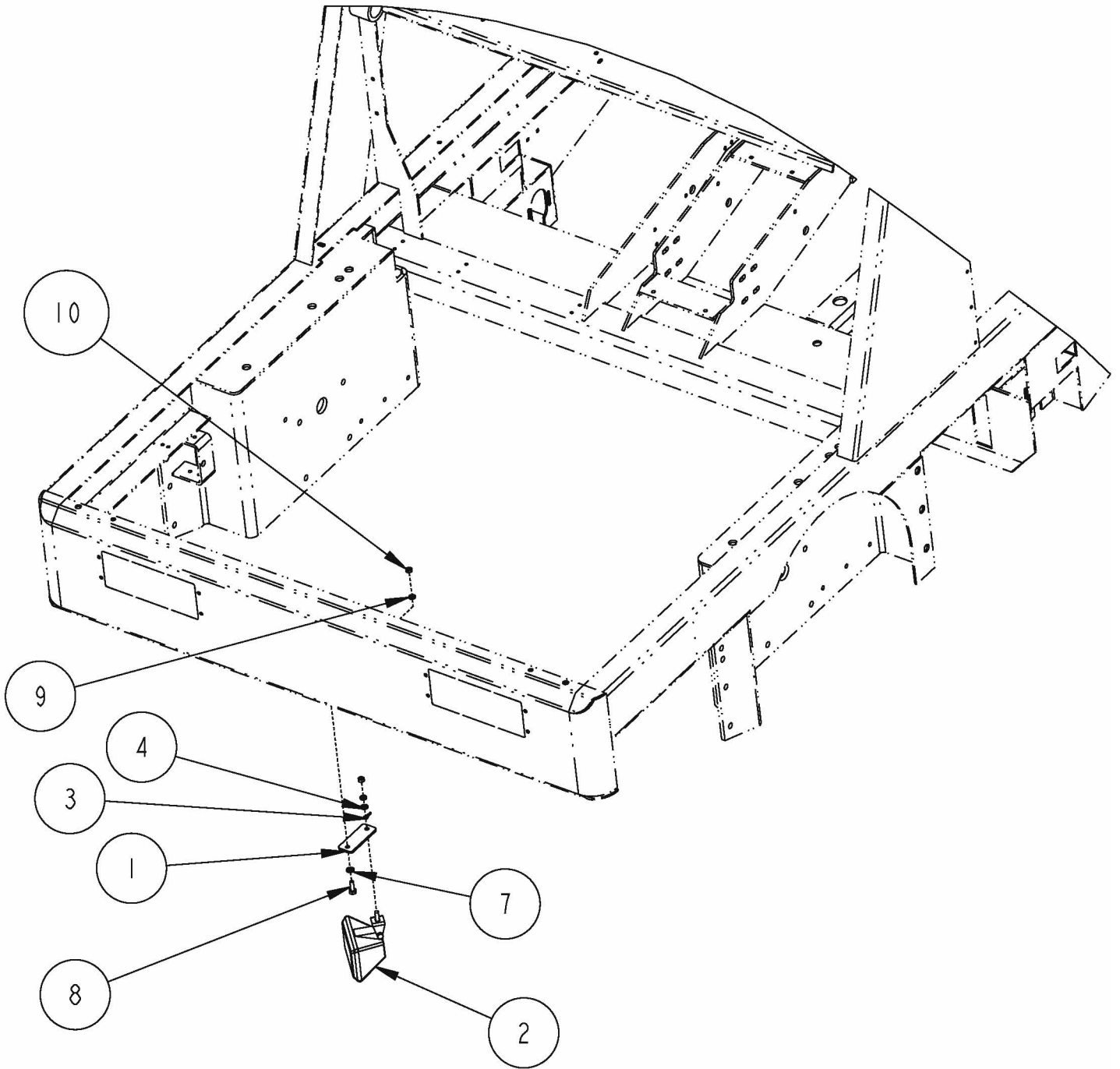

Item	Ref. No.	Qty	Description
	0880-361	1	Curb Light Option NOTE 1
1	7-08-01286	1	Bracket, Side Broom Light
2	56304768	1	Lamp-12V
3	2-00-04282	1	Ring Terminal
4	2-00-02303	1	Lock Washer, 5/16 HS Med.
5	2-00-04578	1	Terminal (.156 Male)
6	8-90-07358	1	Ground Wire
7	2-00-00409	1	Flat Washer, .687 x .344 x .062
8	2-00-02708	1	Screw, 5/16-18 x 1.0 Hex Head
9	2-00-00530	1	Lock Washer, 5/16
10	2-00-00585	1	Nut, 5/16-18 Hex

NOTE 1: HEADLIGHTS REQUIRED TO ACCOMPANY THIS OPTION

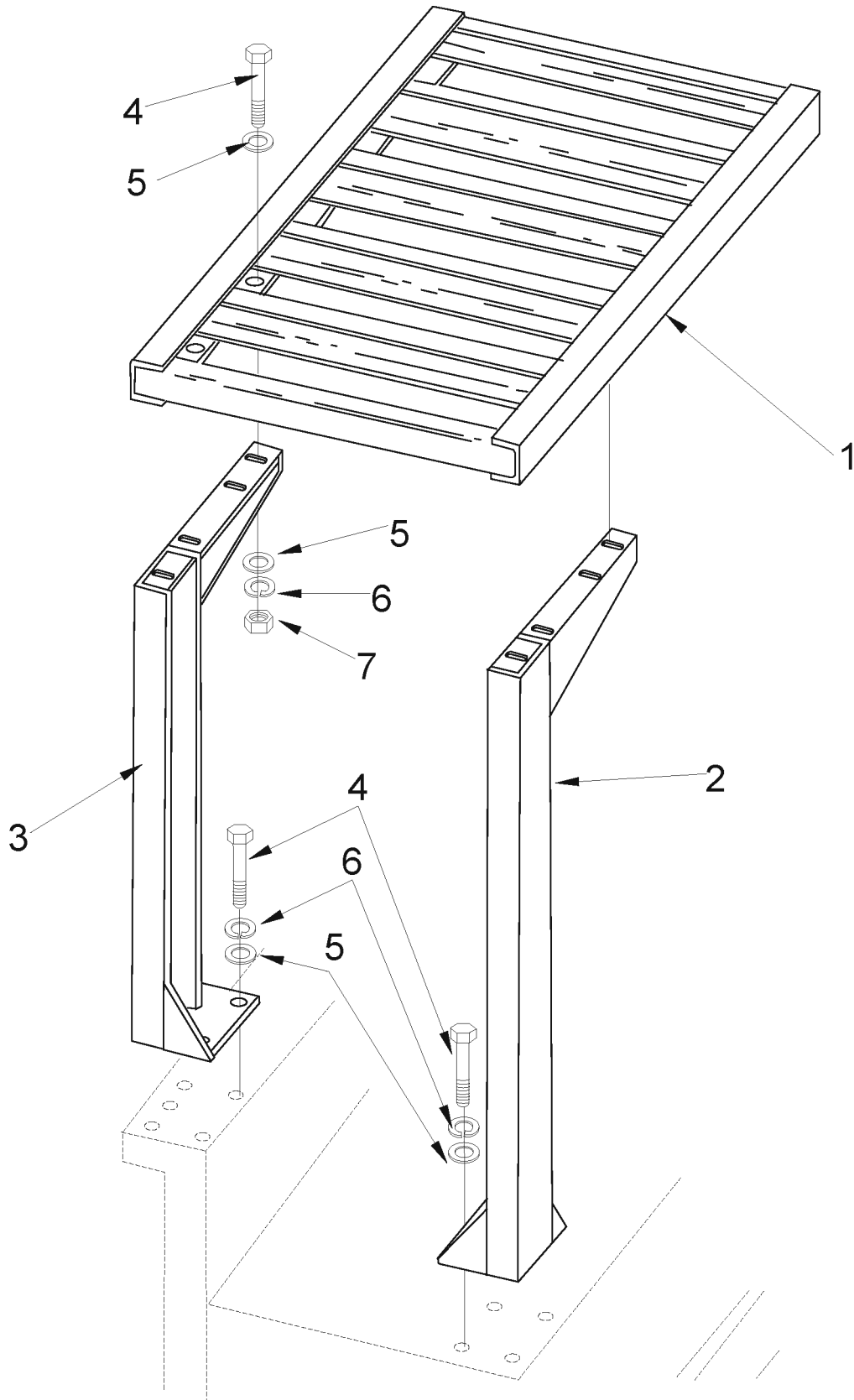

Item	Ref. No.	Qty	Description
	56516756	1	Overhead Guard Option
1	56514900	1	Guard
2	56516762	1	Right Hand Upright Guard
3	56516759	1	Left Hand Upright Guard
4	2-00-00240	16	Screw, 1/2-13 x1.250 HHC
5	2-00-00420	4	Flat Washer, 1.000 x .515 x .0622
6	2-00-02312	16	Lock Washer, Helical Spring 1/2 Med
7	2-00-00596	8	Nut, Hex 1/2-13 x.750 x .515

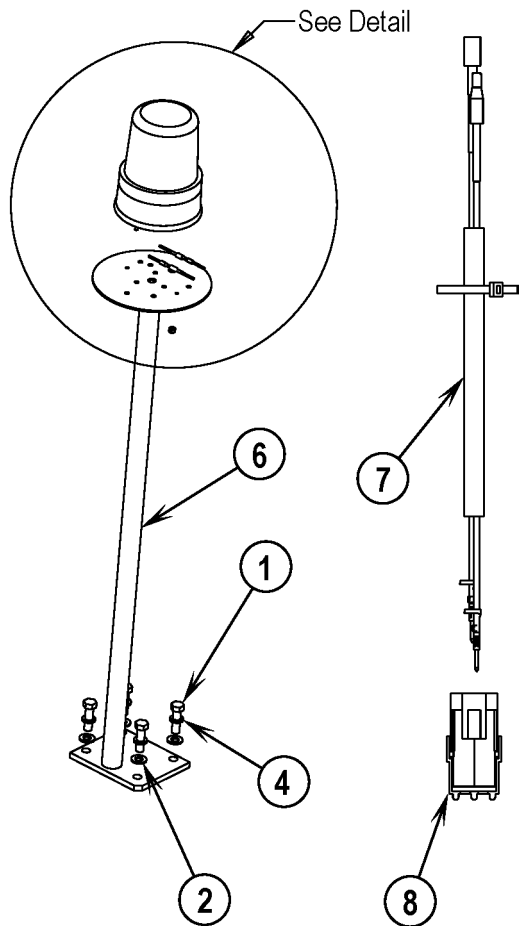
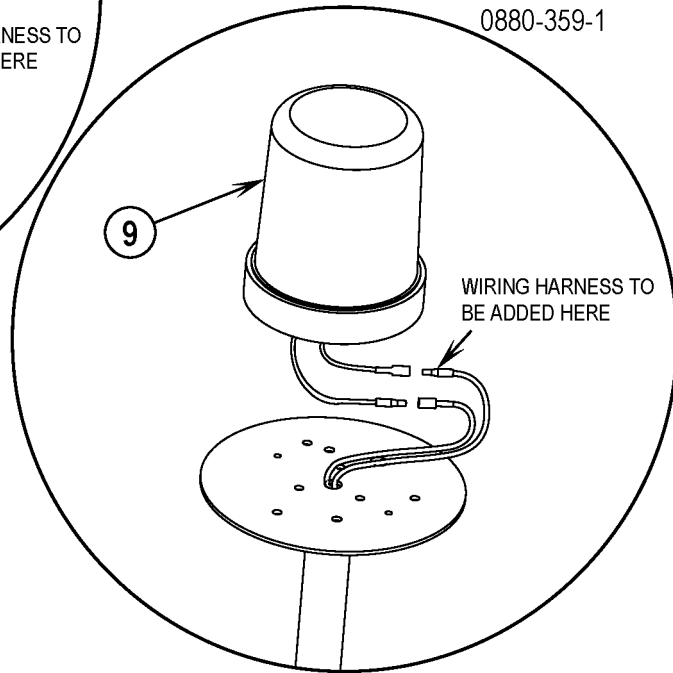
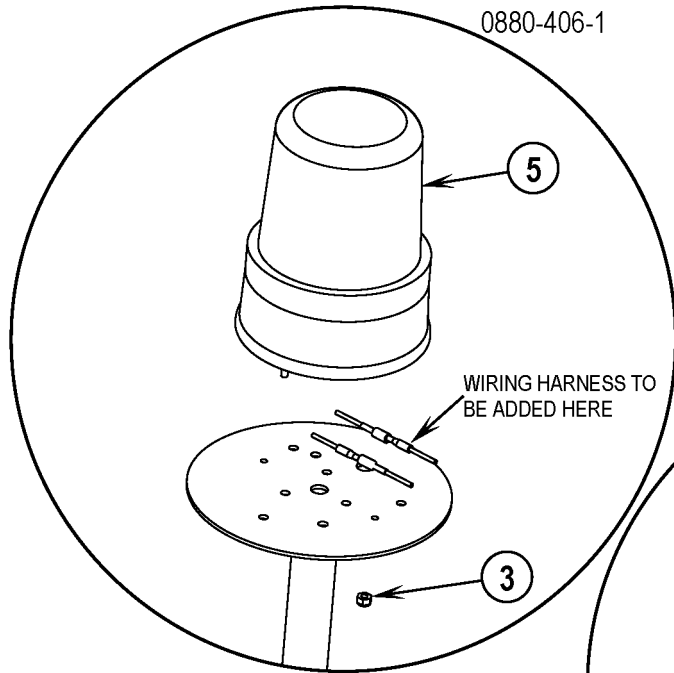

Item	Ref. No.	Qty	Description
	0880-406-1	1	Rotating Light Option
1	2-00-00241	4	Bolt 1/2-13 X 1-3/4 LG
2	2-00-00405	4	Flat Washer, 1.063 x .531 x .094
3	2-00-01246	2	Nut-#10-24 Elastic Stop Nut
4	2-00-02312	4	Washer, 1/2" Lock
5	8-40-05039	1	Warning Light, Amber Revolving
6	56514904	1	Pole, Light
7	56109254	1	Harness, Warning Light
8	56462360	1	Connector, 2-Way

Item	Ref. No.	Qty	Description
	0880-359-1	1	Flashing Light Option
1	2-00-00241	4	Bolt 1/2-13 X 1-3/4 Lg
2	2-00-00405	4	Flat Washer, 1.063 x .531 x .094
4	2-00-02312	4	Washer, 1/2" Lock
6	56514904	1	Pole, Light
7	56109254	1	Harness, Warning Light
8	56462360	1	Connector, 2-Way
9	8-40-05041	1	Light, Emergency, Amber

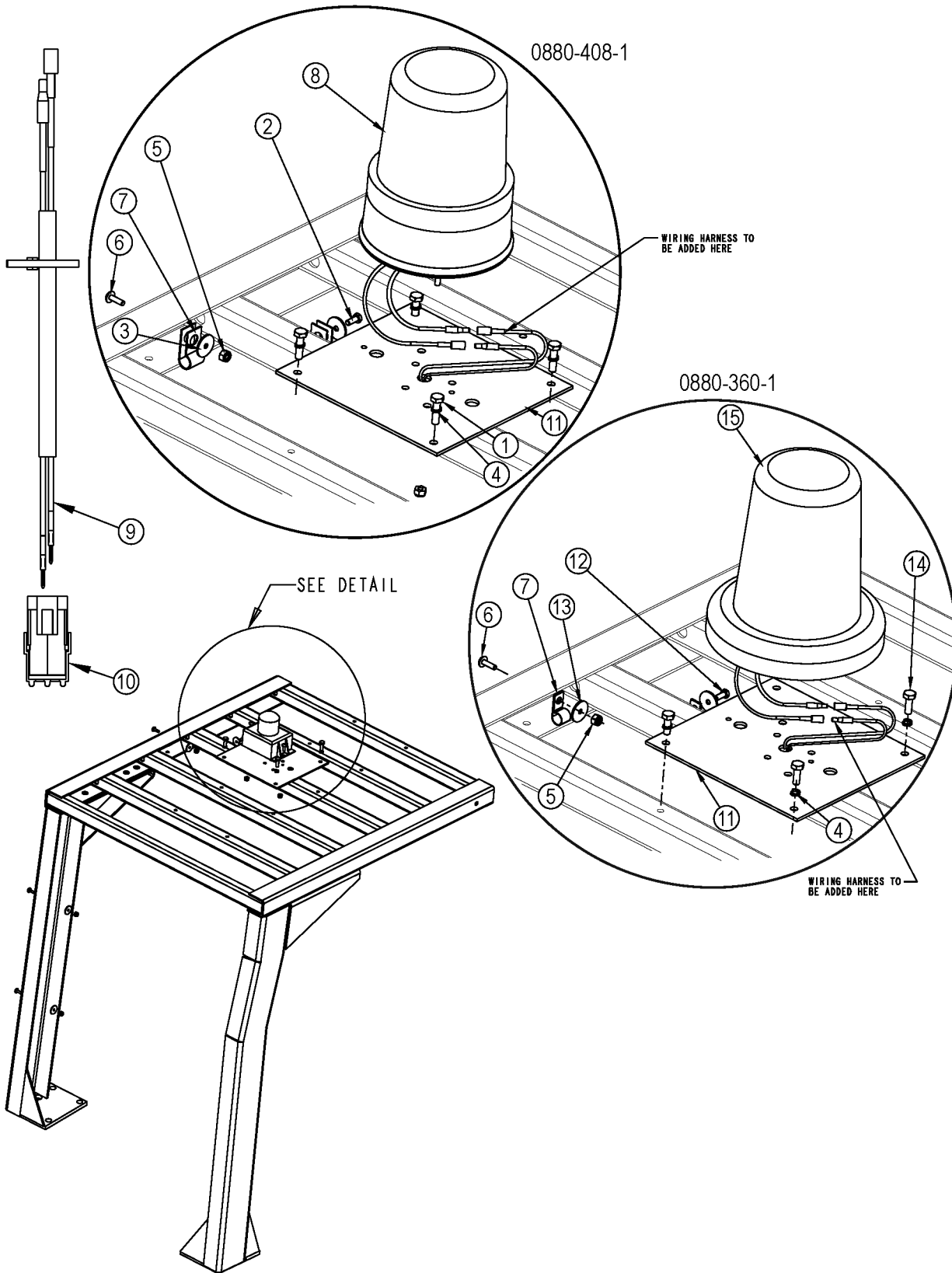

Item	Ref. No.	Qty	Description
	0880-408-1	1	Rotating Light Option
1	56002883	4	Scr, Hex SS 1/4-20 x 1.00
2	56009039	1	Scr, Hex Thd Form 10-24 X .50
3	56009096	4	Wsh, Flt .193 X .875 X .060
4	2-00-00548	4	1/4" Lock Washer
5	2-00-01246	5	Nut-#10-24 Elastic Stop Nut
6	2-00-03062	3	Screw, #10-24 X 5/8 LG
7	2-00-04602	4	Clamp
8	8-40-05039	1	Warning Light, Amber Revolving
9	56109253	1	Harness, Warning Light
10	56462360	1	Connector, 2-Way
11	56514906	1	Plate, Flasher
Item	Ref. No.	Qty	Description
	0880-360-1	1	Flashing Light Option
4	2-00-00548	4	1/4" Lock Washer
5	2-00-01246	3	Nut-#10-24 Elastic Stop Nut
6	2-00-03062	3	Screw, #10-24 X 5/8 LG
7	2-00-04602	4	Clamp
9	56109253	1	Harness, Warning Light
10	56462360	1	Connector, 2-Way
11	56514906	1	Plate, Flasher
12	56009039	1	Scr, Hex Thd Form 10-24 X .50
13	56009096	4	Wsh, Flt .193 X .875 X .060
14	2-00-00221	4	Bolt-Hex Head, Finished, 1/4-20x3/4 LG
15	8-40-05041	1	Light, Emergency, Amber

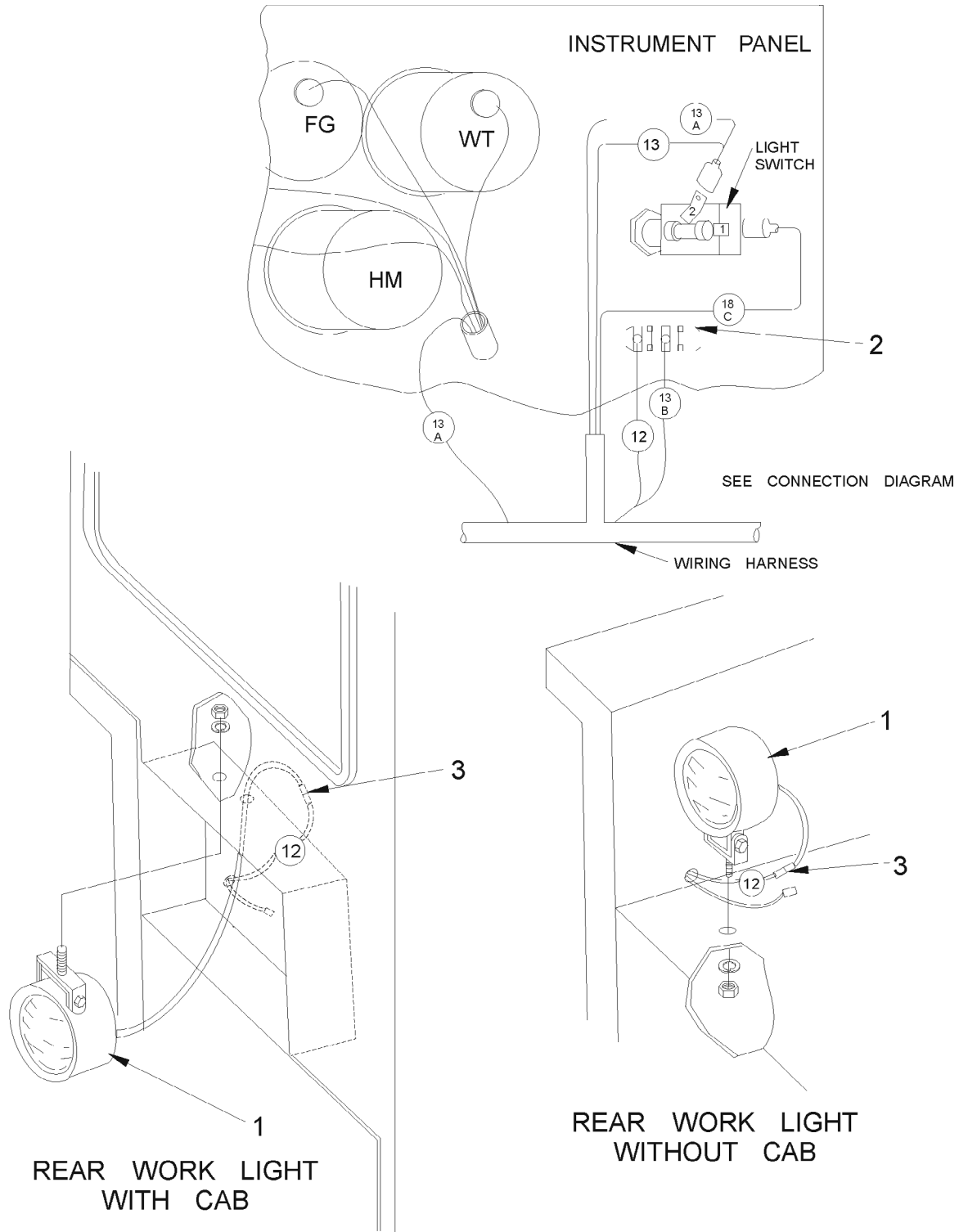

Item	Ref. No.	Qty	Description
	0880-391	1	Rear Work Light Option
1	56304768	1	Lamp-12V
2	8-82-00059	1	Switch, SPST on/off
3	2-00-04578	1	Terminal, Male Bullet

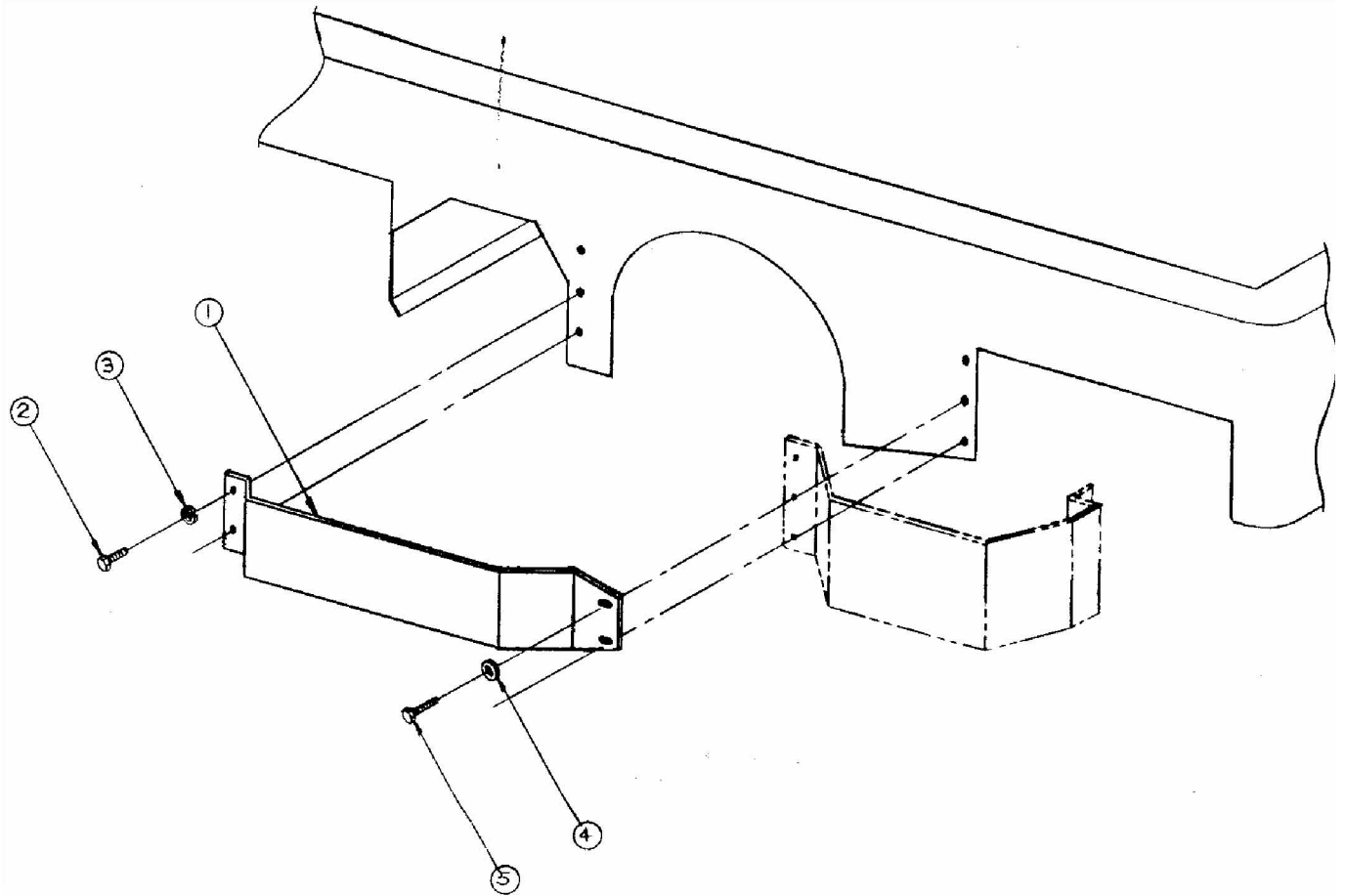

Item	Ref. No.	Qty	Description
	56516865	1	Front Wheel Guards Option
1	56516864	2	Guard, Front Wheel
2	2-00-00240	4	Screw, 1/2-13 x 1.25 HHC
3	2-00-02312	4	Lock Washer, 1/2 Helical Spring
4	2-00-04159	4	Flat Washer, 9/16 ID
6	2-00-00241	4	Screw, 1/2-13 x 1.75 HHC

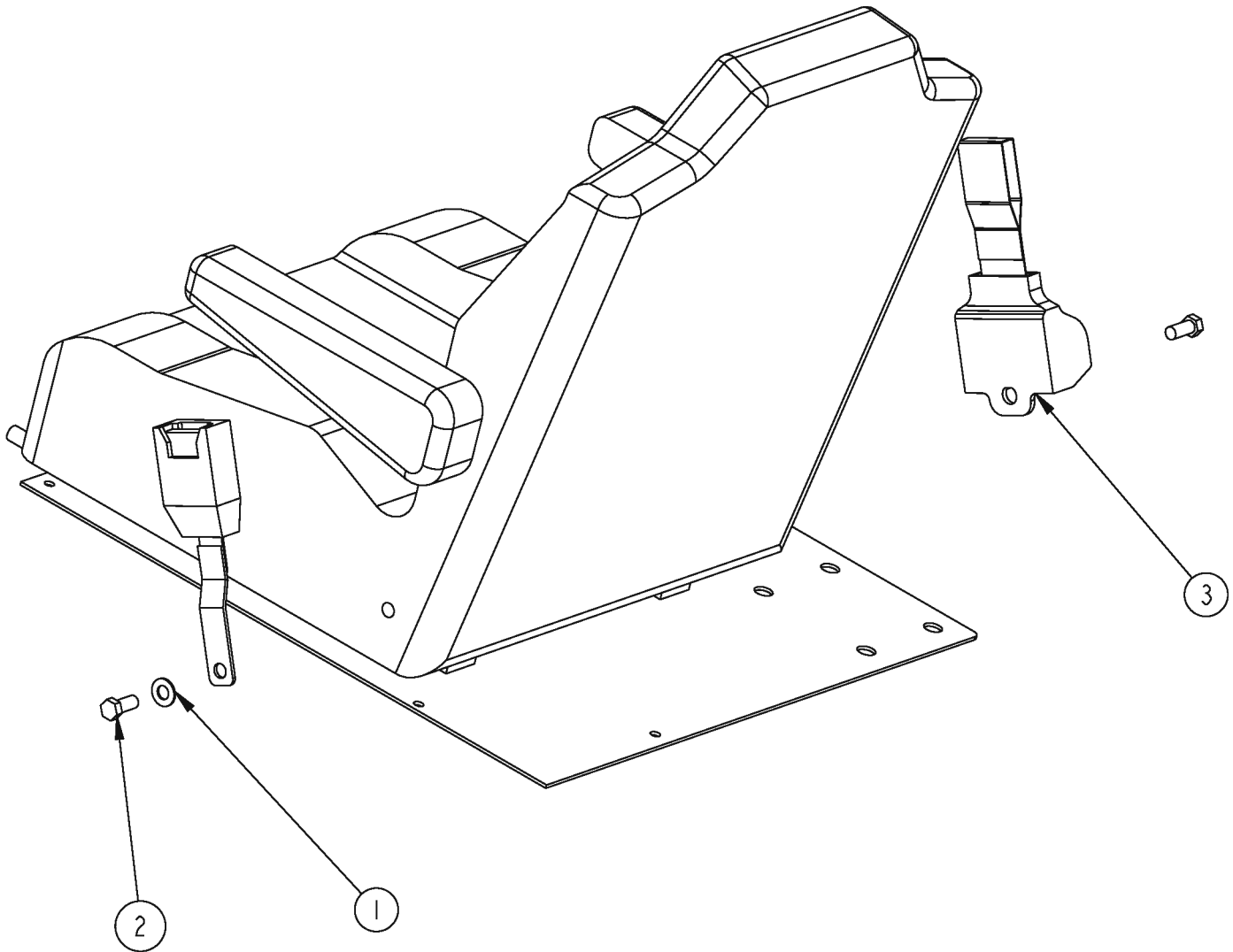

Item	Ref. No.	Qty	Description
	0880-720	1	Retractable Seat Belt Option
1	2-00-00415	1	Washer, .94 ID x .47 OD x .062
2	2-00-03334	2	Screw, 7/16-20 x .75
3	56109301	1	Retractable Seat Belt

Timed filter shaker Option only

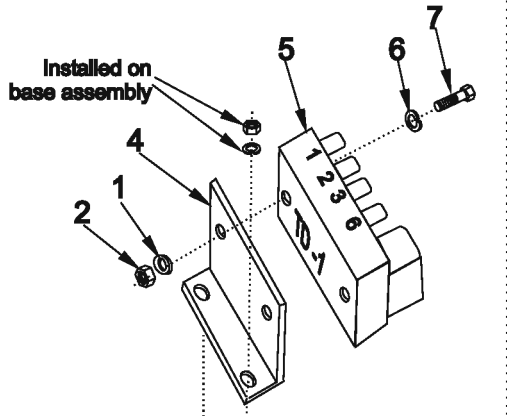

Refer to Instrument panel connection diagram for assembly instructions.
(Wires existing in standard assembly)

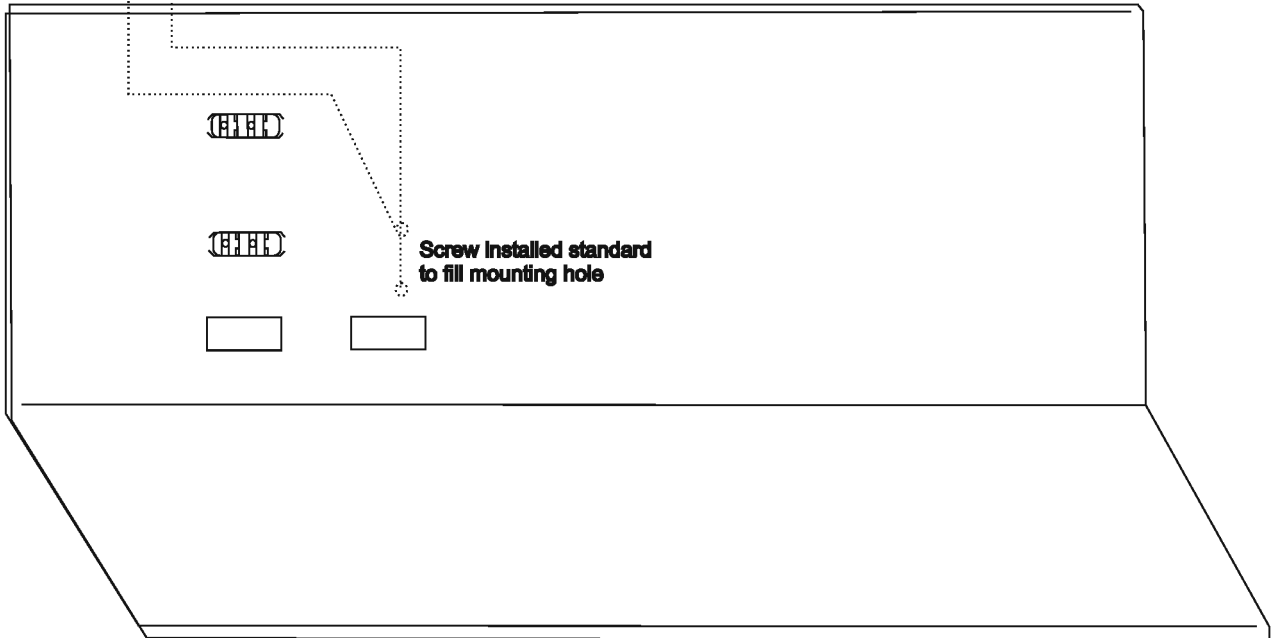

Item	Ref. No.	Qty	Description
	56516764	1	Timed Filter Shaker Motors Option
1	2-00-01499	2	Lock Washer, #6
2	2-00-00605	2	Nut, MS #10-24 x .375 x .125 Hex
3	2-00-00519	2	Lock Washer, #10 Med. Helical Spring
4	56516763	1	Bracket, Timer Relay
5	8-64-05011	1	Timer Relay (20-second delay)
6	2-00-00455	2	Flat Washer, .375 x .156 x .047
7	2-00-00067	2	Screw, #6-32 x 1.0 RHM

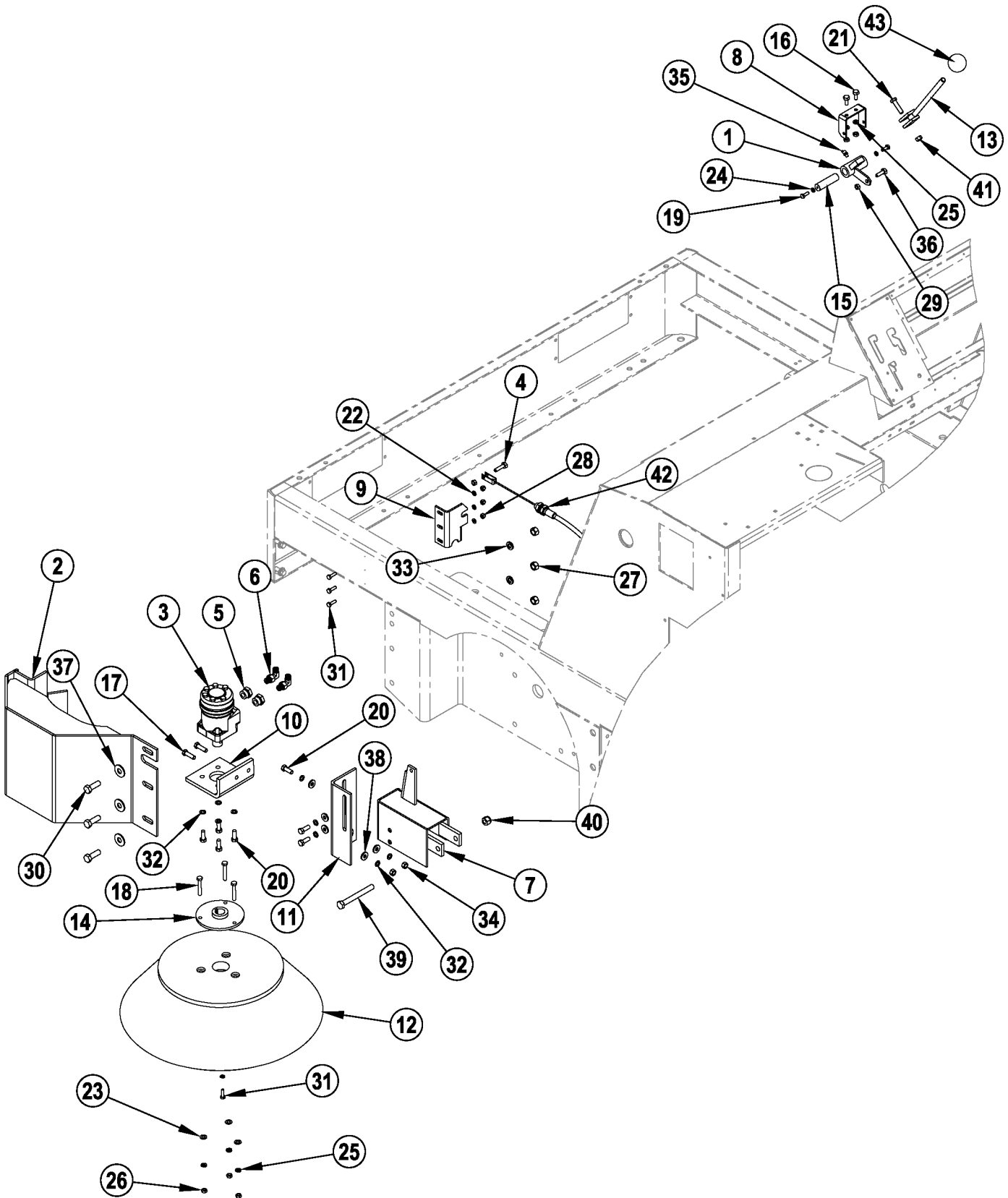

Item	Ref. No.	Qty	Description
	56516861	1	Left Side Broom Option
1	56516810	1	Pivot-Side Broom
2	56516862	1	Weldt-Side Broom Guard
3	0882-047	1	Side Broom Motor
4	2-00-00207	1	Screw, Hex Head 5/16-18 X 1.25"
5	2-00-04915	2	Fitting-Reducer Sae 10 / Sae 6
6	2-00-04926	2	Fitting-90 Sae6 To Ors4
7	8-03-04284	1	Weldt-Side Broom Arm Lh
8	8-08-00646	1	Bracket-Side Broom Pivot
9	8-08-00716	1	Cable / Valve Mount
10	8-08-00739	1	Bracket-Side Broom Lift Arm
11	8-08-00740	1	Bracket-Side Brm Arm
12	8-08-03211	1	Side Broom-Nylon
13	8-16-00034	1	Broom Lift Lever
14	8-25-06008	1	Flange-Curb Broom
15	8-70-05285	1	Shaft-Side Broom Pivot
16	2-00-00208	2	Screw, 5/16-18 X .750 Hhc
17	2-00-00209	2	Bolt, Hex Head, 3/8-16 X 1 1/4 Ss
18	2-00-00218	3	Bolt-Hex Head, 5/16-18
19	2-00-00221	2	Bolt-Hex Head, Finished, 1/4-20x3/4 Lg
20	2-00-00233	9	Bolt-Hex Head, Finished, 3/8-16 X 1.00
21	2-00-00234	1	Screw, 3/8-16 X 1-1/2 Hhc
22	2-00-00407	3	Washer, Flat 1/4
23	2-00-00409	3	Flat Washer, .687 X .344 X .062
24	2-00-00518	3	Washer,Lock,1/4" Helical Spring
25	2-00-00530	5	5/16" Lock Washer
26	2-00-00585	5	5/16-18, Hex Nut
27	2-00-00596	3	Nut, Hex Head, 1/2-13 X .44 Lg
28	2-00-00641	3	Nut, Fiber Insert 1/4-20
29	2-00-00644	2	Nut, Hex, Insert Fiber, 5/16-18
30	2-00-01254	3	Screw, Hex, 1/2-13 X 1.50
31	2-00-01490	4	1/4-20 X 0.875", Hex Head Screw
32	2-00-02310	11	Washer-Lock, 3/8", Helical Spring
33	2-00-02312	3	Washer, 1/2" Lock
34	2-00-02360	2	Nut, Hex, 3/8-16
35	2-00-02558	1	Grease Fitting
36	2-00-02708	1	Screw, Hex Head, 5/16-18 X 1.00"
37	2-00-04159	3	Washer, Flat 1-3/8 X 9/16 X 7/64
38	2-00-04801	7	Flat Washer, 1.00 X .39 X .06
39	2-00-04914	1	Screw 1/2-13 X 4.5" Lg
40	2-00-04936	1	Locknut-Elastic, 1/2-13
41	2-95-04182	1	Nut, Hex, Stop, 3/8-16
42	8-10-00028	1	Cable-Fwd / Rev
43	8-33-02280	1	Hose-#4 Str-Str,9/16-18 Both Ends,190.0 Lg
44	8-39-00003	1	Knob

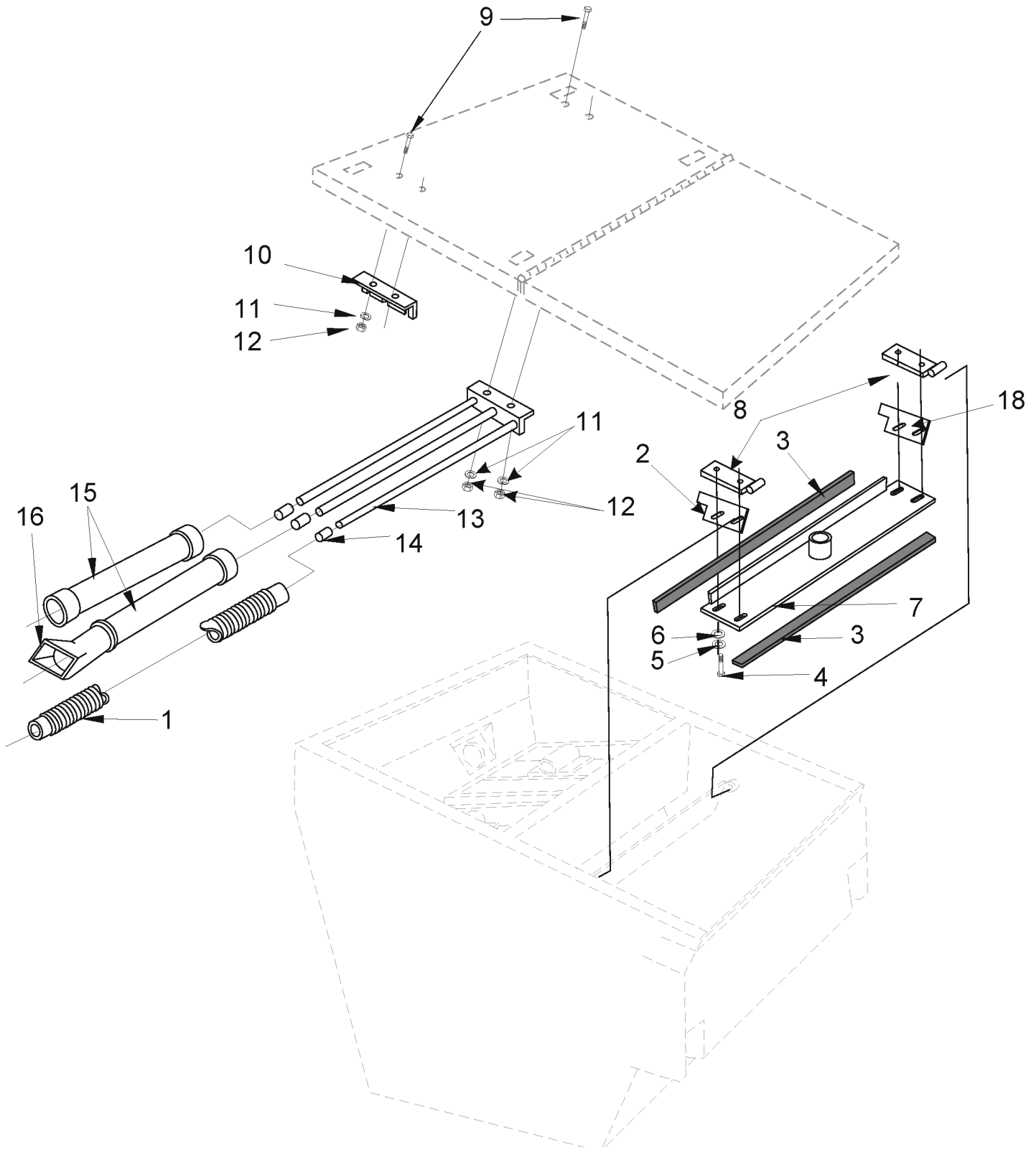

Item	Ref. No.	Qty	Description
	56516765	1	Vacuum Wand Option
3	8-29-00190	2	Gasket
4	2-00-00221	4	Screw, 1/4 - 20 x .750 HHC
5	2-00-00518	4	Lock Washer, Helical Spring 1/4 Med
6	2-00-03702	4	Flat Washer, .625 x .281 x .062
7	56516766	1	Adapter Plate
8	56516768	2	Pivot
9	2-00-01481	4	Screw, 5/16 - 18 x 1.000 RHM
10	56516769	1	Latch Bracket
11	2-00-00530	4	Lock Washer, Helical Spring 5/16 Med
12	2-00-00585	4	Nut, Hex 5/16 - 18 x .500 x .265
13	56516772	1	Hose Storage Bracket
14	8-11-00034	3	Cap
15	8-89-00002	2	Wand Section
16	8-86-08010	1	Floor Tool
17	8-33-02121	1	Vacuum Hose
18	8-25-08183	2	Flap

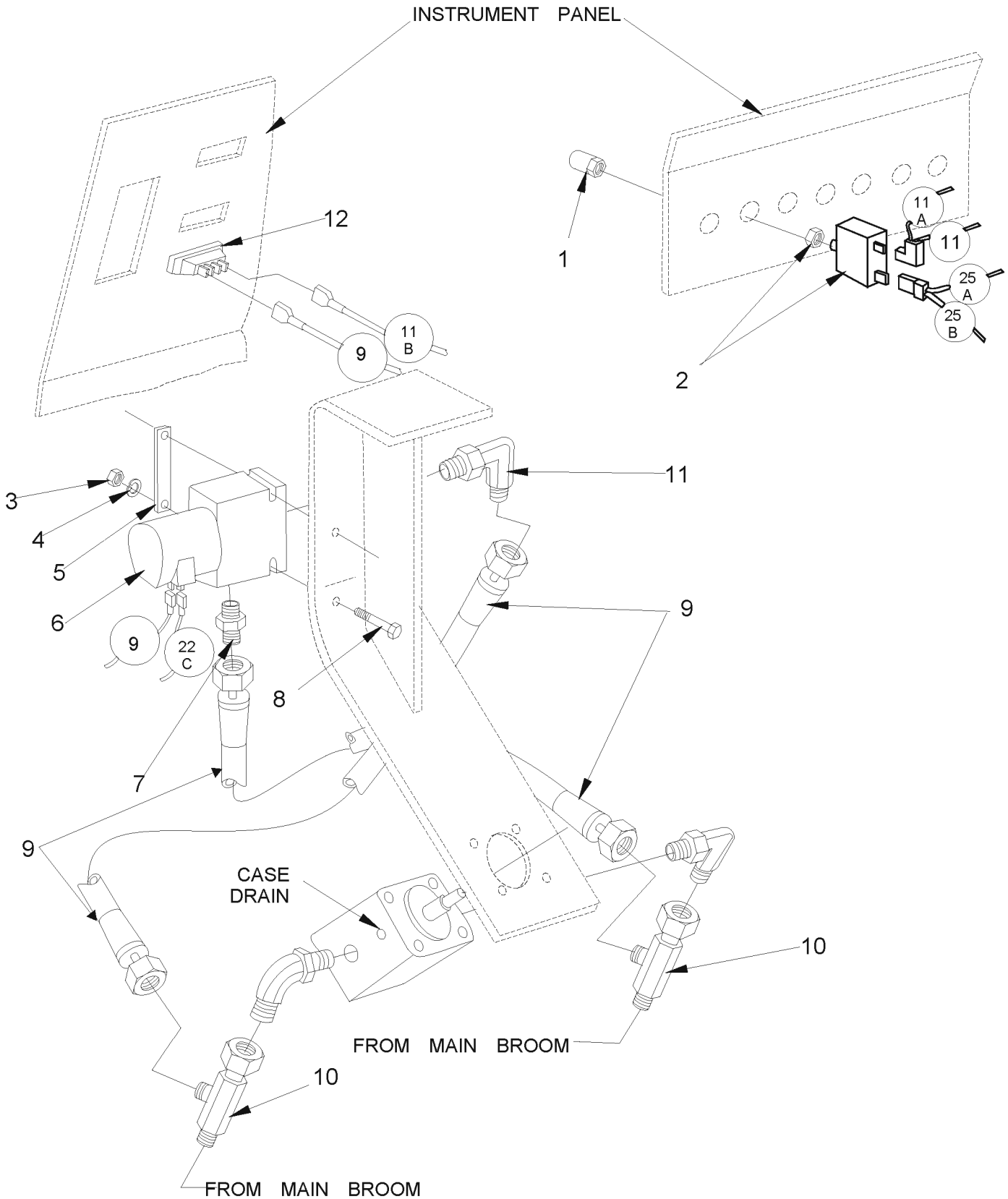

Item	Ref. No.	Qty	Description
	0880-353	1	Wet Sweep Bypass Option
1	8-11-00044	1	Circuit Breaker Boot
2	8-64-00008	1	Circuit Breaker (15A)
3	2-00-00594	2	Nut, Hex 1/4 - 20 x .437 x .218
4	2-00-00518	2	Lock Washer, Helical Spring 1/4 Med
5	8-08-00590	1	Bracket
6	8-88-00042	1	Valve, Solenoid N.C.
	7-14-07005	1	Coil
7	2-00-04970	1	ORFS Connector, 3/4-16 / 13/16-16
8	2-00-02589	2	Screw, 1/4 - 20 x 2.000 HHC
9	8-33-02193	2	Hose, Hydraulic ORS 8/ str.ends - 18"
10	2-00-04928	2	ORFS Run Tee, 13/16 - 16
11	2-00-04885	1	ORFS 90° Elbow, 3/4-16 / 13/16-16
12	8-82-00044	1	Switch SPST

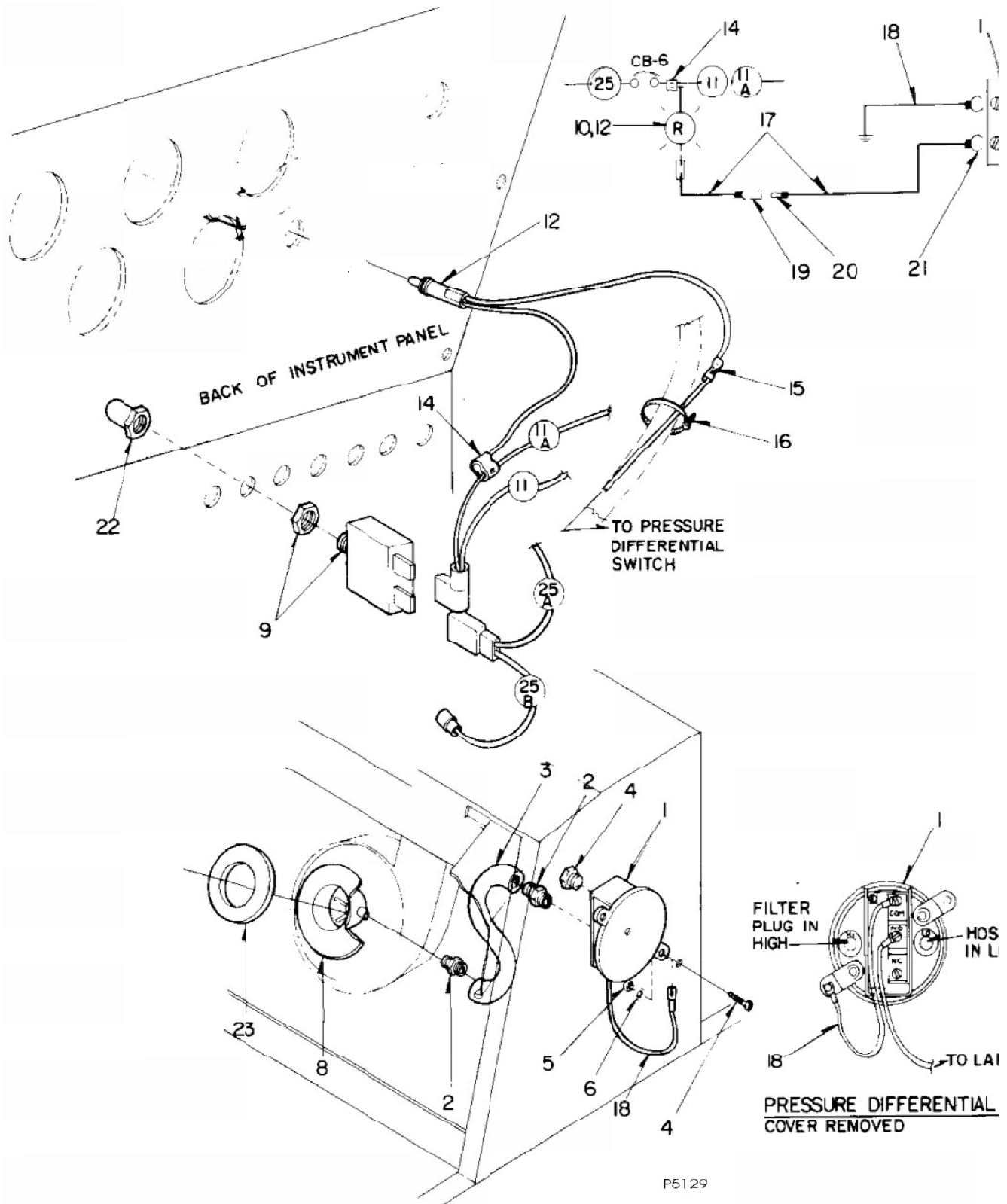

Item	Ref. No.	Qty	Description
	0880-523	1	Clogged Filter Indicator Option
1	8-63-05014	1	Pressure Differential Switch
2	2-00-04518	2	Hose Fitting Barbed, Rigid Pipe Male 1/8 NPT
3	7-87-02155	1	Plastic Hose, 8.000 L.
4	8-24-04075	2	Filter Plug,
5	2-00-04479	2	Connector (3) way
6	2-00-01128	1	Butt Splice
7	2-00-04345	10	Wire Tie
8	8-11-00044	1	Boot
9	8-64-00008	1	Circuit Breaker, 15 AMP
12	56305660	1	Light, Red Led Indicator
14	3-61-00189	16"	Wire, Bulk Black 16 AWG
15	2-00-04717	1	Terminal, #6 Spring Spade
16	2-00-04626	2	Terminal, .156 Female Bullet
17	2-00-04578	1	Terminal, .156 Male Bullet
18	3-61-00249	92.50"	Wire - 16 AWG. GRN.
18A	3-61-00249	20	Wire - 16 AWG. GRN.
19	2-00-03261	1	Grommet

RIGHT SIDE

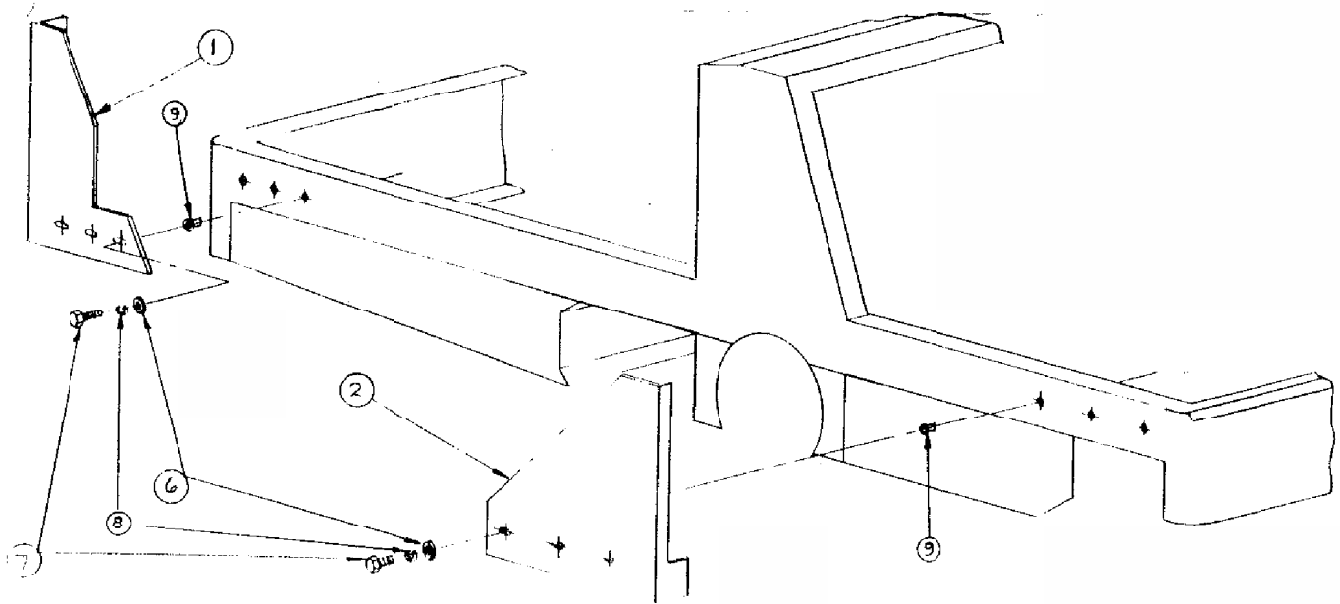

LEFT SIDE

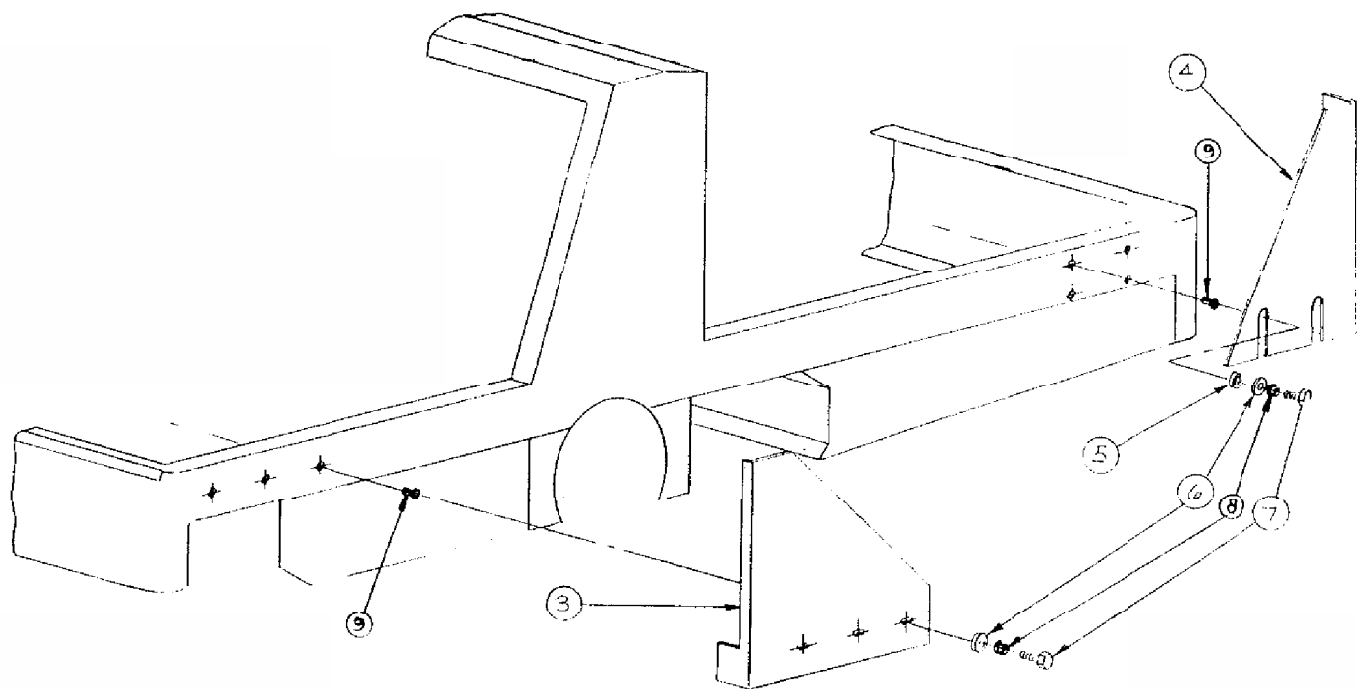

Item	Ref. No.	Qty	Description
	56516847	1	Four Corner Bumper Option
1	56516848	1	Tower Bumper, RH Rear
2	56516849	1	Tower Bumper, RH Front
3	56516850	1	Tower Bumper, LH Front
4	56516851	1	Tower Bumper, LH Rear
5	8-09-01089	4	Bushing
6	2-00-03266	13	Flat Washer
7	2-00-00233	13	Screw, 3/8-16 x 1.0 HHC
8	2-00-02310	13	Lock Washer, 3/8 Heliccal Spring
9	2-00-05347	13	Insert, 3/8-16 Threaded

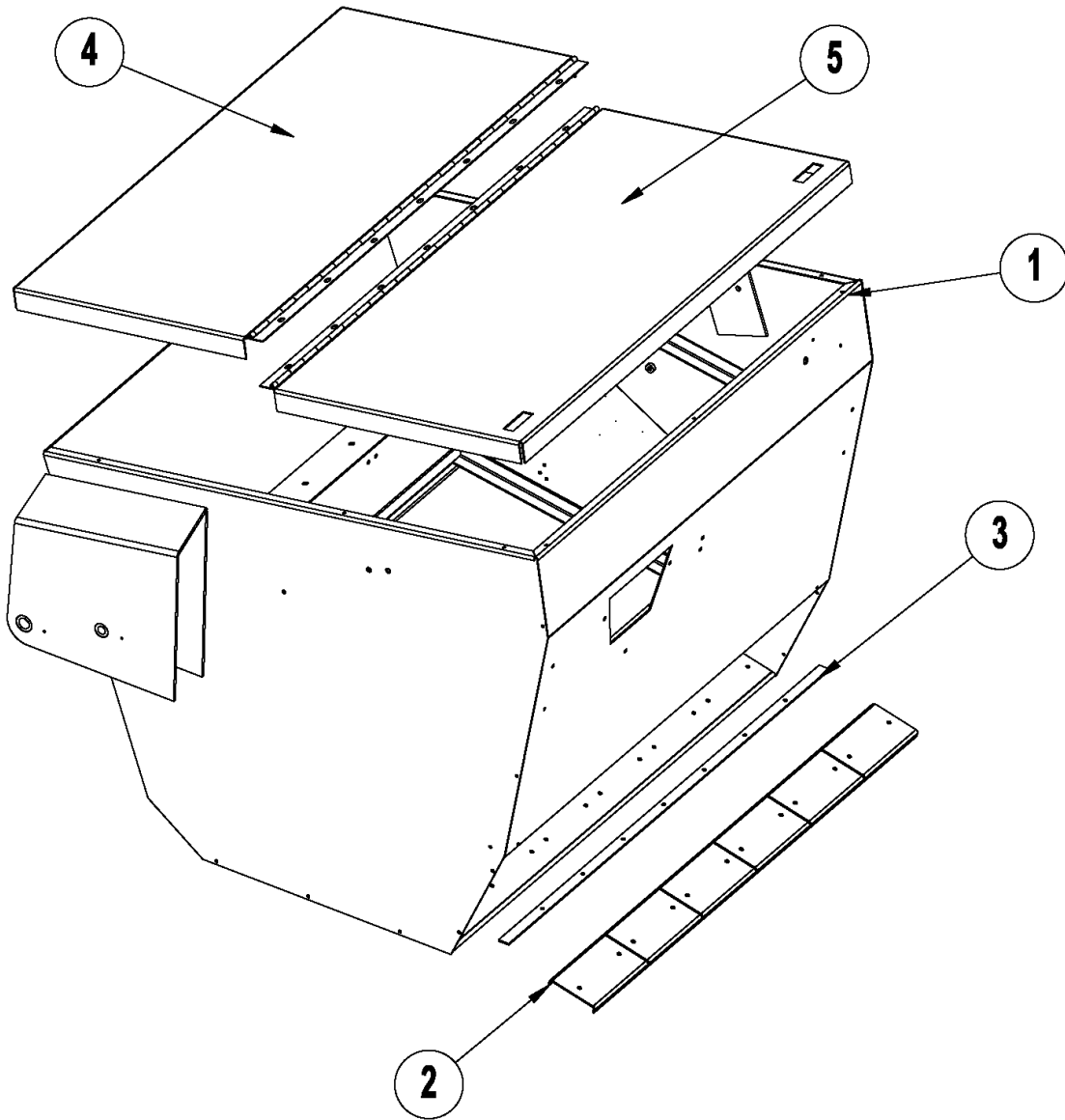

Item	Ref. No.	Qty	Description
	56516860	1	Stainless Steel Hopper Option
1	56516869	1	Hopper, Stainless Steel
2	8-13-07084-1	6	Clamp, Hopper Bottom Flap
3	56516870	1	Strap, Primary Deflector Flap
4	56516872	1	Cover-Lower S/S With S/S Hinge
5	56516871	1	Cover-Upper S/S With S/S Hinge

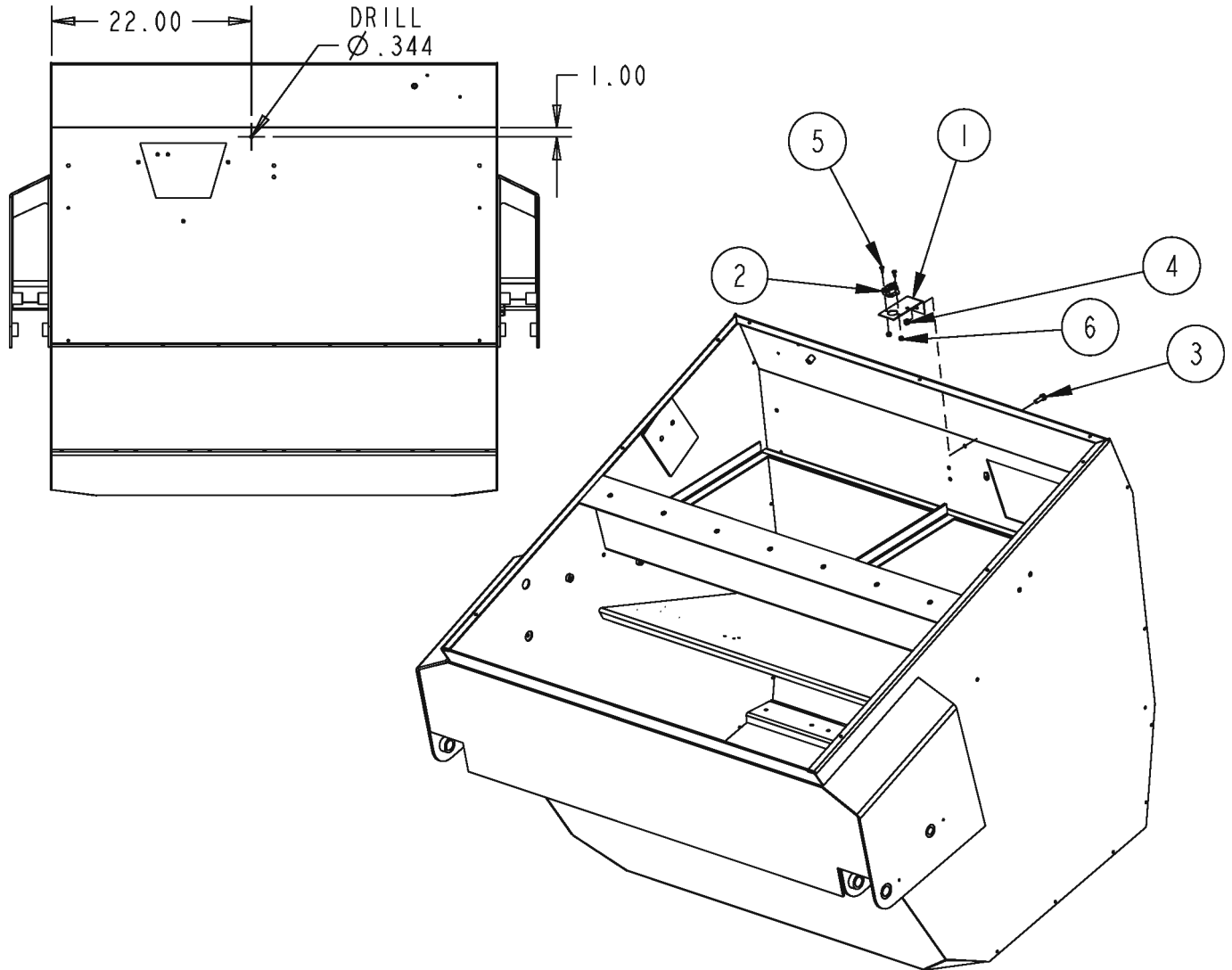

Item	Ref. No.	Qty	Description
	0780-694	1	Hopper High Temp Shutdown Option
1	8-08-00803	1	Bracket, Temperature Switch
2	8-82-00056	1	Switch, Thermostat
3	2-00-00208	1	Screw, 5/16-18 x .750 HHC
4	2-00-00644	1	Nut, 5/16-18 Fiber Insert Hex
5	2-00-00049	2	Screw, 10-24 x 1/2 RHM
6	2-00-01246	2	Nut, 10-24 Elastic Stop

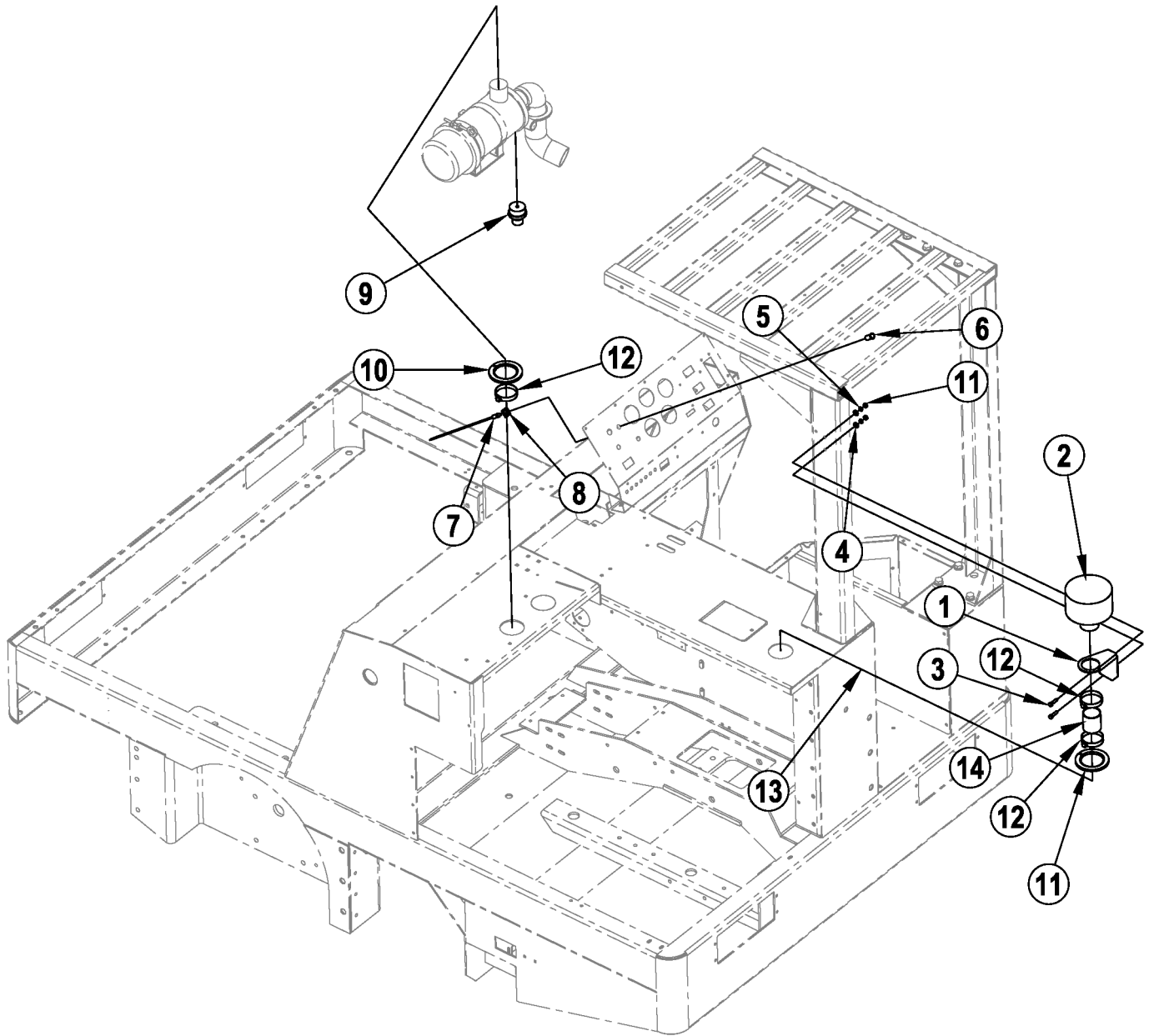

Item	Ref. No.	Qty	Description
	56516867	1	SE Air Cleaner W/Overhead Guard Option (Gasoline/LPG)
	56100840	1	SE Air Cleaner W/Overhead Guard Option (Diesel)
1	56516866	1	Bracket
2	7-24-04107	1	Filter, Pre-Cleaner
3	2-00-00205	2	Bolt, 1/4-20 Fin. Hex Head
4	2-00-03702	2	Washer, .625 x .281 x .063
5	2-00-00518	2	Lock Washer, 1/4 Helical Spring
6	7-41-03004-1	1	Red Lens (Diesel only)
	56305660	1	Light, Red LED Indicator (Gasoline/LPG only)
7	7-40-05027	1	Lamp/Socket Assembly (14V) (Diesel only)
8	2-00-04735	1	Clip, Spring (Diesel only)
9	7-82-00065	1	Switch, Dust Load Indicator (Gasoline/LPG only)
	56100842	1	Switch, Dust Load Indicator (Diesel only)
10	7-21-04022	2	Edging
11	2-00-00594	2	Nut, 1/4-20 Hex
12	2-00-02216	3	Clamp, Hose
13	8-33-02114	1	Hose (10 ft.)
14	7-87-02203	1	Coupling

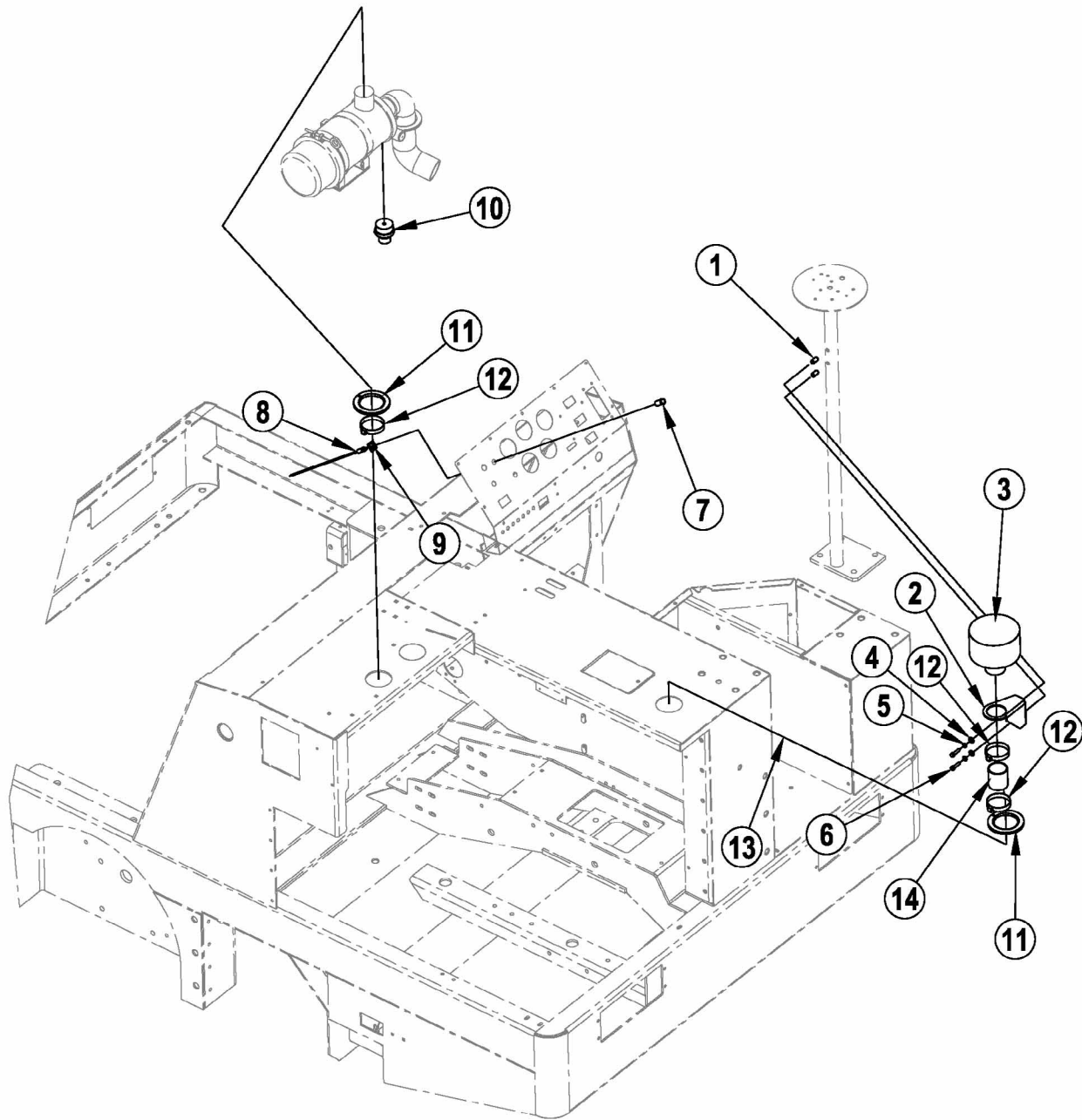

Item	Ref. No.	Qty	Description
	56516873	1	SE Air Cleaner W/O Overhead Guard Option (Gasoline/LPG)
	56100841	1	SE Air Cleaner W/O Overhead Guard Option (Diesel)
1	2-00-05261	2	Nutsert, 1/4-20
2	56516866	1	Bracket
3	7-24-04107	1	Filter, Pre-Cleaner
4	2-00-03702	2	Washer, .625 x .281 x .063
5	2-00-00518	2	Lock Washer, 1/4 Helical Spring
6	2-00-00205	2	Bolt, 1/4-20 Fin. Hex Head
7	7-41-03004-1	1	Red Lens (Diesel only)
	56305660	1	Light, Red LED Indicator (Gasoline/LPG only)
8	7-40-05027	1	Lamp/Socket Assembly (14V) (Diesel only)
9	2-00-04735	1	Clip, Spring(Diesel only)
10	7-82-00065	1	Switch, Dust Load Indicator (Gasoline/LPG only)
	56100842	1	Switch, 30" Load Indicator (Diesel only)
11	7-21-04022	2	Edging
12	2-00-02216	3	Clamp, Hose
13	8-33-02114	1	Hose (10 ft.)
14	7-87-02203	1	Coupling
[]	3-71-00302	1	Hose (Diesel only)

[] = Not Shown

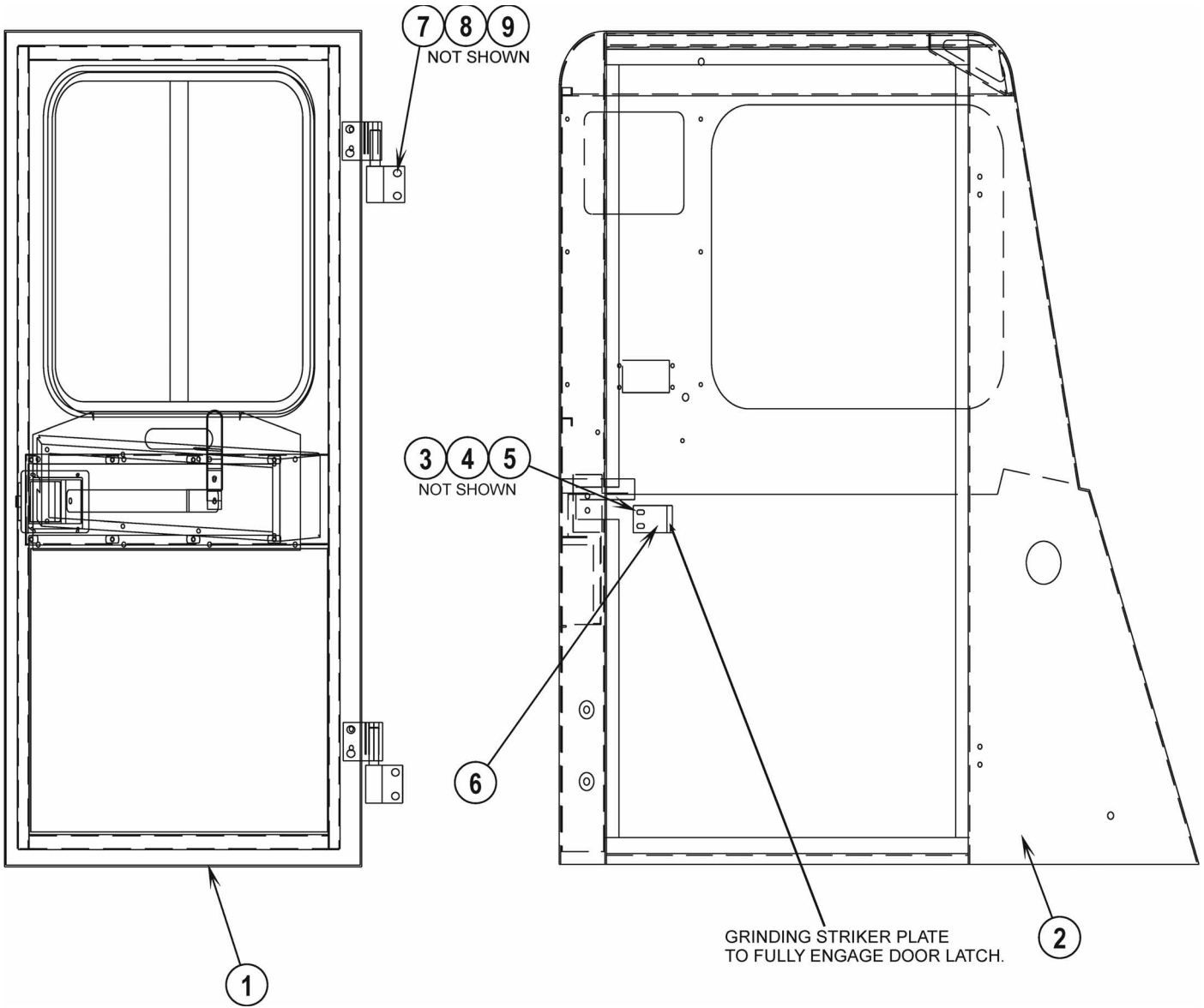

Item	Ref. No.	Qty	Description
	56516868	1	Cab Assembly
1	56516882	1	Door Assembly
2	56516887	1	Cab Weldment
3	2-00-00644	2	Nut-Ins-Fibre .31-18 Zn PL
4	2-00-00207	2	Scw-HHC .313-18 x 1.25 GR 5 ZN
5	2-00-00409	2	Wshr-Flat .688 x .344 x .063 St
6	8-45-05009	1	Lug-Striker
7	2-00-00208	4	Scw-HHC .313-18 x .75 GR5 ZN
8	2-00-00419	4	Wshr-Flat .625 x .328 x .031 Stl.
9	2-00-00646	4	Nut-Ins-Fibre .31-18 Thin/Zn

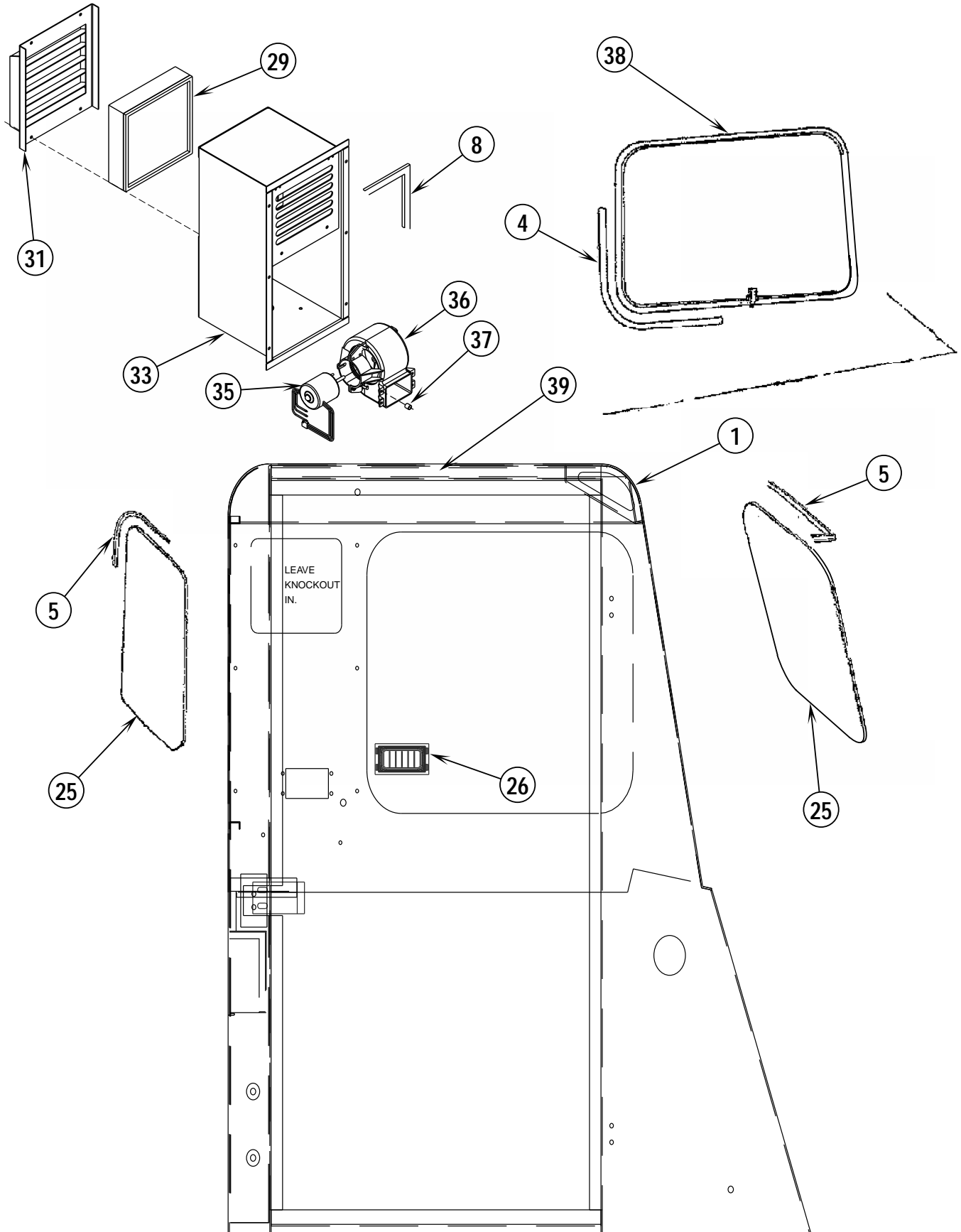

Item	Ref. No.	Qty	Description
	56516881	1	Cab Assembly W/Pressurizer
1	56516868	1	Cab Assembly
4	56516880	1	Seal Side Window (84")
5	56516879	2	Seal Window (88")
8	56516878	1	Gasket Blower Housing (71.66")
17	2-00-03041	4	Screw-Hshc .25-20 X 1.25
25	8-90-01005	2	Window-Rear
26	8-18-03025	1	Adj. Lower Vent Cover
29	8-24-04141	1	Filter - Pressurizer
31	56516891	1	Blower Housing Louver-Weldment
33	56516890	1	Blower Box Weldment
35	0882-055	1	Motor
36	8-23-00015	1	Blower Assy
37	56516889	4	Spacer
38	8-90-01006	1	Canopy Window- Cab
39	8-34-09026	2	Insulation- Cab Roof Interior
[]	56516888	1	Cover Console
[]	7-82-00011	1	Switch
[]	7-39-00019	1	Knob
[]	8-18-00449	1	Decal-Fan
[]	8-18-00422	1	Decal - Control-Cb-11
[]	7-64-00022	1	Circuit Breaker - 20 Amp
[]	0895-117	1	Harness - Cab
[]	8-34-09036	1	Insulation-Cab Left Side Int.
67	56109406	1	Spacer Cab

[] = Not Shown

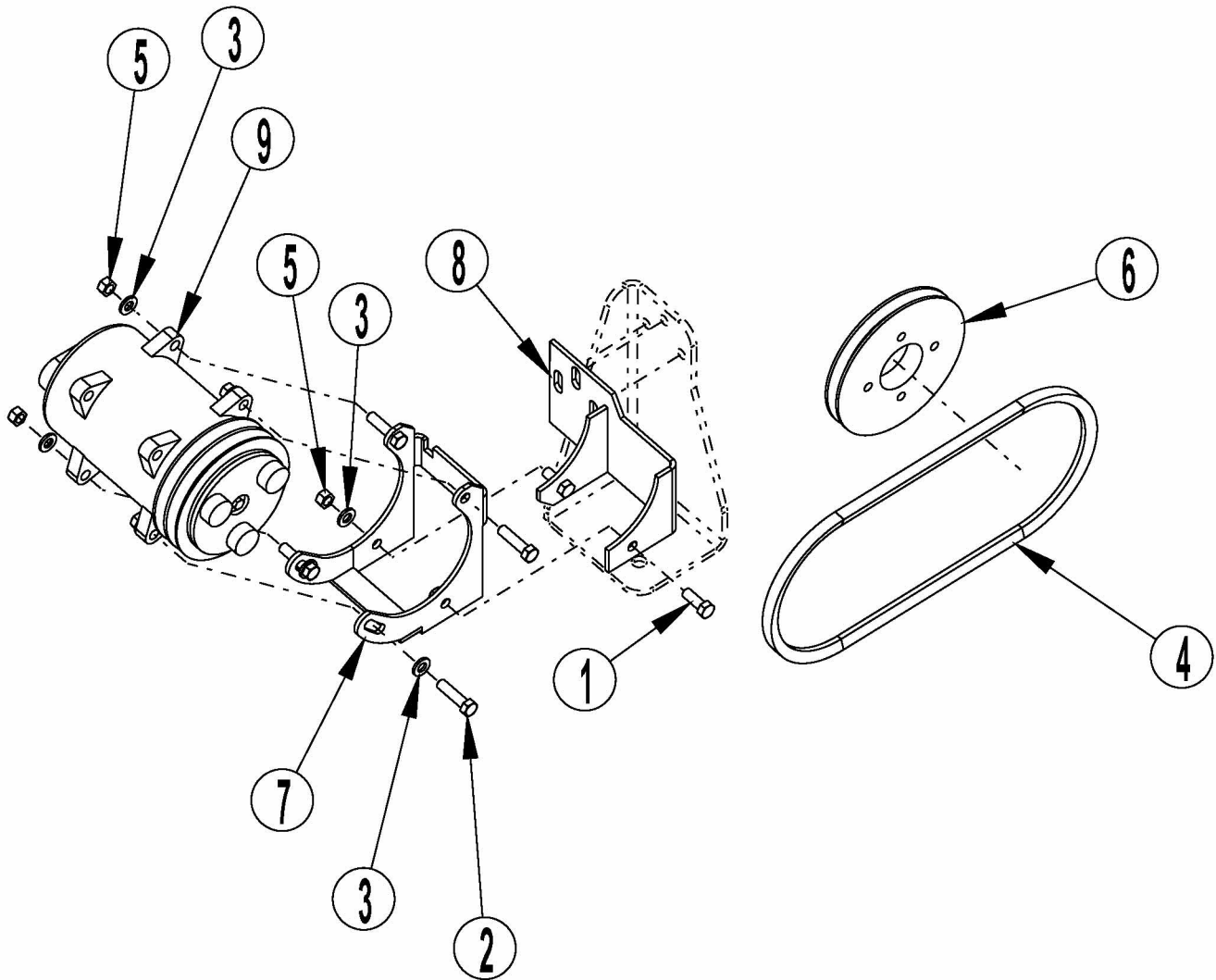

Item	Ref. No.	Qty	Description
	0780-692	1	A/C Option-Diesel
1	2-00-00233	2	Bolt-Hex Head, Finished, 3/8-16 X 1.00
2	2-00-00234	4	Screw, 3/8-16 X 1-1/2 Hhc
3	2-00-00402	8	Washer, 25/64" Id X 3/4" Od
4	2-00-06151	1	Belt-V #41360
5	2-95-04182	6	Nut, Hex, Stop, 3/8-16
6	7-60-00206	1	Pulley-V Belt
7	8-08-00950	1	Bracket, A/C Compressor
8	8-08-00951	1	Bracket, A/C Compressor
9	0782-177	1	A/C Compressor, Dual Groove
*	2-00-00828	1	Term-Stakon T71 Type 1
*	2-00-03360	2	Conn-Butt Splice Insulated
*	56109175	1	Fuse Holder, In-Line Mini
*	56109242	1	Ac Assy/S4q2 (Large Dsl)
*	56109247	1	Harness, Ac
*	56109248	1	Fuse, Mini 30 Amp

* = Not Shown

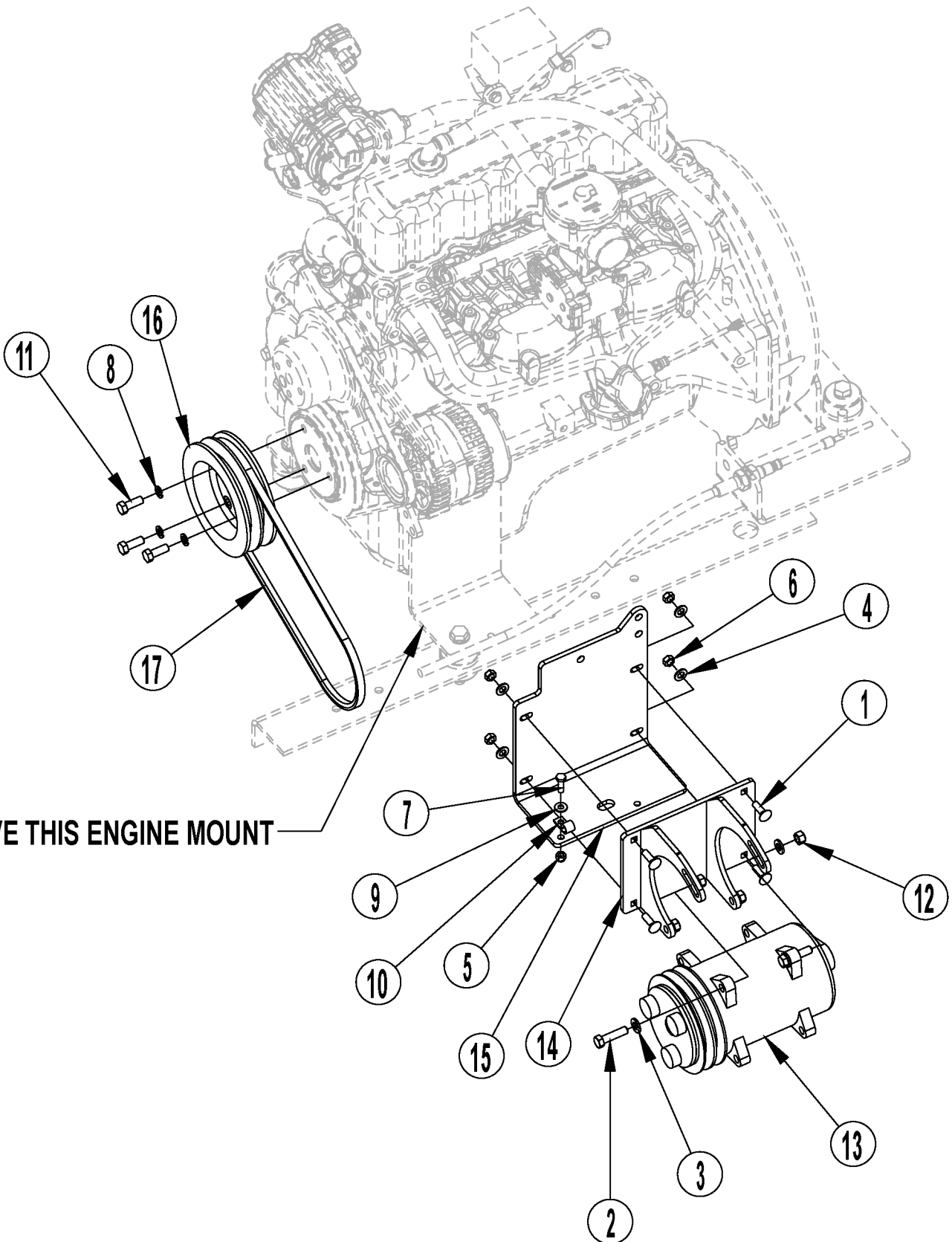

REMOVE THIS ENGINE MOUNT

Item	Ref. No.	Qty	Description
	0880-762	1	A/C Option-GM 3.0L
1	2-00-00196	4	Bolt-Car, .31-18 X 1 Gr 5 Zn
2	2-00-00234	4	Screw, 3/8-16 X 1-1/2 Hhc
3	2-00-00402	8	Washer, 25/64" Id X 3/4" Od
4	2-00-00409	4	Flat Washer, .687 X .344 X .062
5	2-00-00641	1	Nut, Fiber Insert 1/4-20
6	2-00-00644	4	Nut, Hex, Insert Fiber, 5/16-18
7	2-00-01490	1	1/4-20 X 0.875", Hex Head Screw
8	2-00-02310	3	Washer-Lock, 3/8", Helical Spring
9	2-00-03702	1	Washer, .625 X .281 X .063
10	2-00-04602	1	Clamp
11	2-00-05381	3	Scr, Hhc .375-24x1.00 Gr 8 Zn
12	2-95-04182	4	Nut, Hex, Stop, 3/8-16
13	0782-177	1	A/C Compressor, Dual Groove
14	56109054	1	Bracket, A/C Compressor
15	56109057	1	Bracket, Engine Mount
16	56109058	1	Pulley, Dual Groove, 3.0l
17	56109059	1	V-Belt
*	2-00-00828	1	Term-Stakon T71 Type 1
*	2-00-03360	2	Conn-Butt Splice Insulated
*	56109175	1	Fuse Holder, In-Line Mini
*	56109243	1	Ac Assy/Gm 3.0l Engine
*	56109247	1	Harness, Ac
*	56109248	1	Fuse, Mini 30amp

* = Not Shown

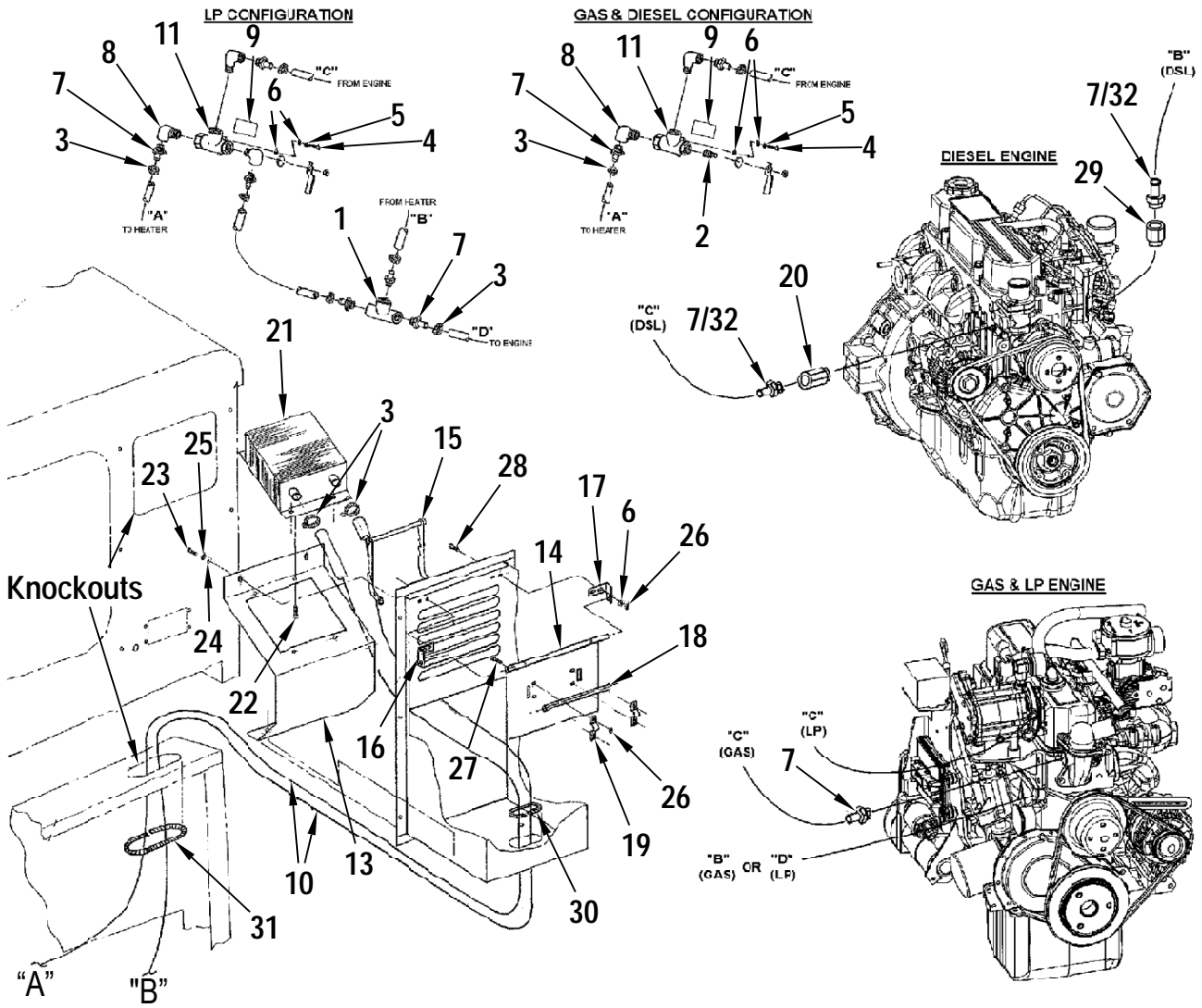

Item	Ref. No.	GAS Qty	LPG Qty	DSL Qty	Description
	56516902	1			Heater Option – Gasoline / Petrol
	56516901		1		Heater Option – LPG
	56516900			1	Heater Option – Diesel
1	2-00-04497	0	1	0	FTG-Tee
2	2-00-02474	1	0	1	Plug-Pipe-Galv .50
3	2-00-03407	6	10	6	Clamp-Witteck-10P
4	2-00-03059	2	2	2	SCW-PH THM #10-24 x .38 ZN
5	2-00-00519	2	2	2	LK Wash #10 Med Sec ZN
6	2-00-00426	8	8	8	WSHR-FL .500 x .219 x .063 STL ZN
7	7-25-02040	3	7	2	Hose Fitting
8	2-00-04328	2	3	2	Elbow-Street 90 Deg .50NPT
9	8-18-00331	1	1	1	Decal-Heater Valve
10	3-71-00125	25	25	25	5/8 ID Blck Heater Hose SAE20
11	8-88-00043	1	1	1	Heater Valve
13	56516897	1	1	1	Bracket-Heater
14	56516896	1	1	1	Blower Housing Door Weldment
15	56516895	1	1	1	Blower Housing Door Handle
16	56516894	1	1	1	Hinge (RH)
17	56516899	1	1	1	Hinge (LH)
18	8-55-08135	1	1	1	Cab Heater-Pivot Pin
19	8-13-07094	2	2	2	Conduit Clamp
20	56109081	0	0	1	Adapter M16 x 1.5-3/8NPT
21	8-62-01015	1	1	1	Heater Core
22	2-00-01994	4	4	4	SCR-TF/PRH #8-15 x .75 type A
23	2-00-00220	4	4	4	SCW-HHC .25-20 x .63 GR 8 ZN
24	2-00-03702	4	4	4	WSHR-FL .625 x .281 x .063 STL ZN
25	2-00-00518	4	4	4	LK WASH 1/4 Med Section ZN
26	2-00-01246	8	8	8	#10-24 Nylon Insert Thin
27	2-00-00006	4	4	4	SCREW-FHM #10-24 x .63 ZN
28	2-00-00049	4	4	4	SCW-RHM 10-24 x .50 ZN PL
29	56109082	0	0	1	Adapter 3/8BSPT – 3/8NPT
30	8-21-04015	1	1	1	Moulding-Rubber
31	8-21-04039	1	1	1	Edging-Engine Cover
32	2-00-05972	-	-	2	Hose Fitting – 90 Deg

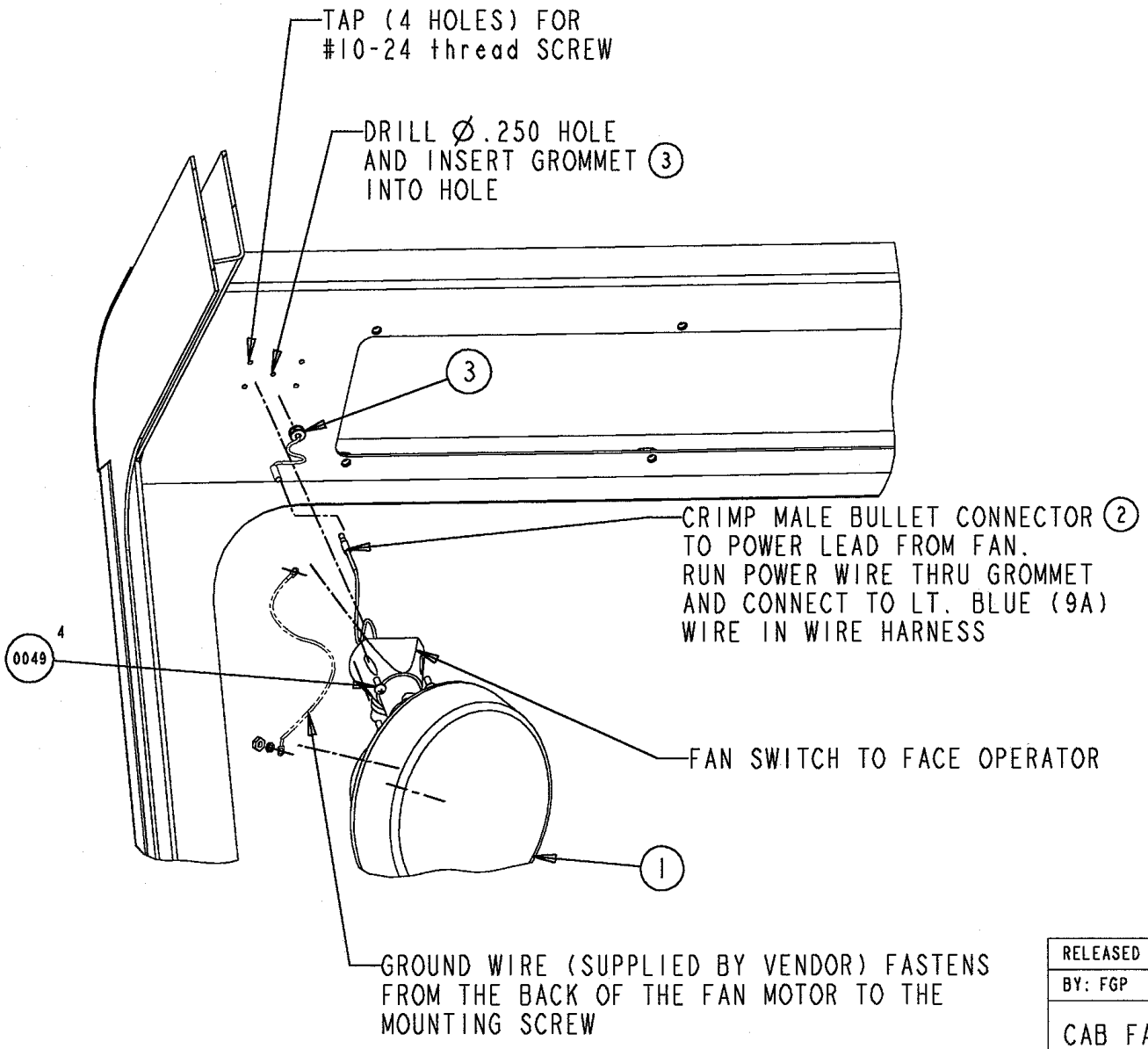

RELEASED
BY: FGP
CAB F/

Item	Ref. No.	Qty	Description
	0880-615	1	Cab Fan Option
1	8-23-00016	1	Defroster Fan
2	2-00-04578	1	Connector (Male Bullet)
3	2-00-04200	1	Grommet
	2-00-00049	1	Screw

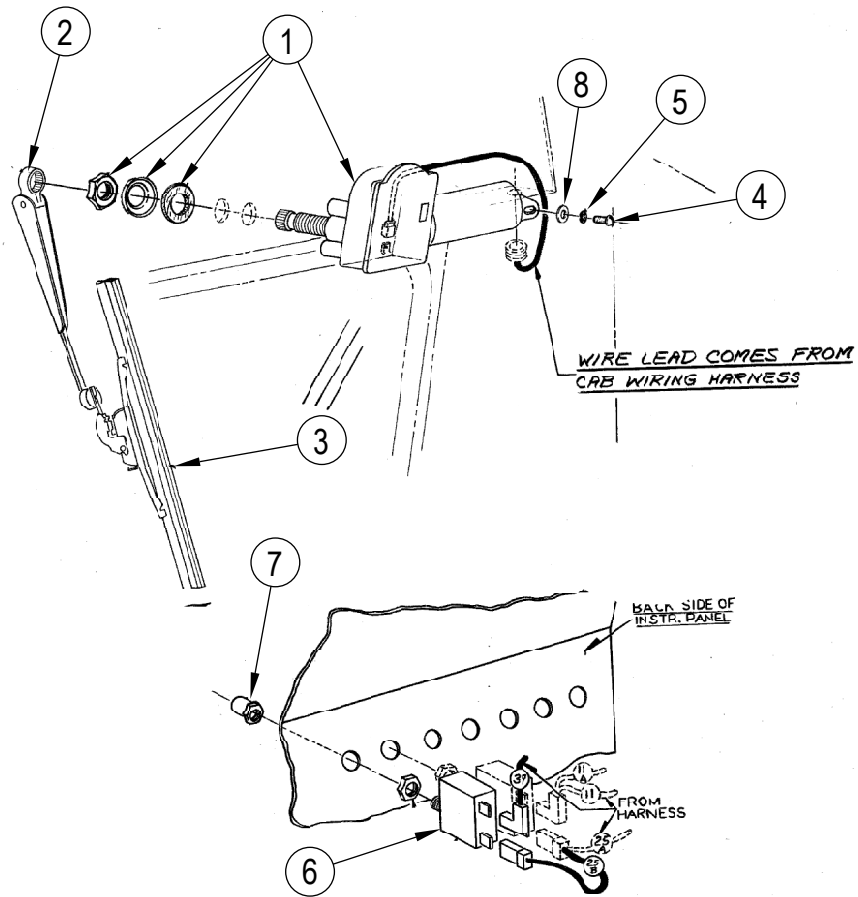

Item	Ref. No.	Qty	Description
	0880-388	1	Cab Wiper Option
1	0882-067	1	Wiper Motor-Single Speed
2	8-03-04315	1	Wiper Arm
3	8-06-03004	1	Wiper Blade
4	2-00-00049	1	Screw-RHM 10-24 x .50
5	2-00-00519	1	Lockwasher-10-Split
6	8-64-00008	1	Circuit Breaker-15 Amp
7	8-11-00044	1	Boot
8	2-00-00426	1	Flat Washer-.50 x .218 x .06

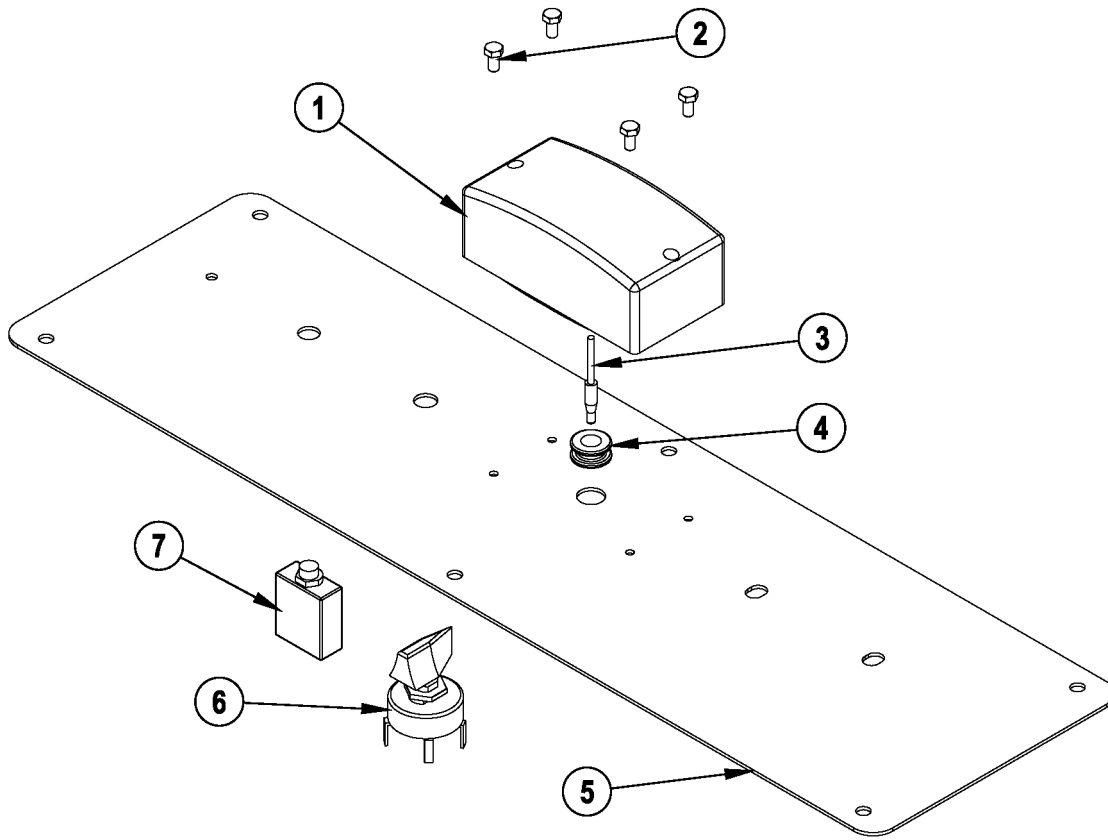

Item	Ref. No.	Qty	Description
	0880-616	1	Cab Dome Light Option
1	56109264	1	Light-Interior-Dome
2	56009012	4	Scr-Hex Thd Form 10-24 x .38
3	2-00-04578	1	Terminal-Bullet Male
4	2-00-00491	1	Grommet
5	8-16-07364	1	Access Cover
6	7-82-00011	1	Switch-4 Position Rotary



**Nilfisk
Advance**

setting standards

Nilfisk-Advance, Inc.
14600 21st Avenue North
Plymouth, MN 55447-3408
www.nilfisk-advance.com
Phone: 800-989-2235
Fax: 800-989-6566
©2009 Nilfisk-Advance, Inc.