

Advance Terra[®] 28B

Walk-Behind Sweeper



DEFINING
CLEANING
INNOVATION



Combines All-Surface Sweeping
and Edge Cleaning



Advance Terra® 28B

Walk-Behind Sweeper

Superior Pick-up on Hard and Soft Floors.

The performance of Advance's new Terra® 28B walk-behind sweeper leaves wide-area vacuums in the dust. Its 28 inch wide sweep path handles carpet with 2.5 times more productivity than a 28 inch wide-area vacuum (ISSA data). Plus, the Terra 28B's side broom eliminates the need for edge cleaning after sweeping. Compact and easy to maneuver for even your smallest operators, the Terra 28B is rated at just 59 dB A – making it one of the quietest sweepers in the industry.

The Terra 28B features A.S.A.P. (All Surface All Purpose) sweeping technology. Sweeping efficiency is maximized as the operator transitions from one floor type to another without having to change the type of broom. Many times the transition can also be completed without having to adjust the broom height. The A.S.A.P. technology is made possible with a unique main broom design coupled with a well engineered skirting system. The specially designed main broom contains dual rows of soft and coarse bristles that will pick up everything from dirt and sand, to paper and plastic pop bottles on carpet and hard floor. The long-running, maintenance-free gel battery comes standard on the Terra 28B, while an onboard battery charger allows the operator the flexibility to plug the sweeper in any place there is an outlet.

The Terra 28B was built with your green cleaning program in mind. The machine's extra quiet operation allows daytime cleaning and contributes to operator safety. The Terra 28B sweeper utilizes a durable polyester panel filter shaker in the marketplace. Using the filter shaker on a regular basis gives you the most out of your filter. It minimizes filter changes while maximizing your indoor air quality. And since the Terra 28B is a bag-less sweeper, there's no money spent on bags, or time spent changing them.

One-Touch™ operation, a streamlined design and superior maneuverability make this sweeper easy for any operator to use. The Terra 28B sweeper features traction assist for fast and easy sweeping. Tools-free broom removal and adjustment makes for easy cleaning of the sweeper at the end of an operator's shift.

Ideal Applications Include —

- Schools and Universities
- Hospitals / Healthcare
- Commercial Cleaning Facilities
- Hotels
- Office Buildings
- Government Buildings and Installations
- Airports / Train Stations / Bus Depots
- Casinos
- Health Clubs



ADVANCE TERRA® 28B INCREASES CARPET-CLEANING PRODUCTIVITY BY OVER 200%



Terra® 28B Walk-Behind Sweeper – 31.5 inch (80 cm) battery

20,190 ft²/hr (1,875 m²/hr)



Wide Area Vacuum – 28 inch (71 cm) cord-electric

8,000 ft²/hr (743 m²/hr)



*Based on productivity numbers published by the International Sanitary Supply Association (ISSA)





Terra® 28B easily cleans both hard and soft floors without having to change brooms



Adjustable handle folds for easy storage



Filter shaker easily combs filter for cleaning. A well maintained filter will last for over 100 hours of operation

GREEN

- Air Quality:** A durable polyester panel filter traps dust particles.
- Safety:** Operating sound level of 59 dB A meets LEED-EB, GS-42 and other green-cleaning noise standards.
- Sustainability:** Machine is standard with maintenance-free gel battery.
- Performance:** A.S.A.P. sweeping technology (all surface all purpose) allows the Terra® 28 to easily transition from hard to soft floor without having to change brooms.



Two position, single button operation



Tools-free removal of brooms and hopper makes for easy maintenance



The Terra® 28B walk-behind sweeper boosts productivity with its ability to clean soft and hard floors.

Defining Cleaning Innovation...

- Our products are designed using innovative technology that increases productivity and drives down the cost to clean.
- You can get expert service and maintenance for your Advance machines from factory-trained personnel around the world. Fast parts delivery, too.
- Maintain peak performance with Nilfisk Genuine OEM Parts.

Nilfisk Genuine OEM Parts

Standard Features

- Maintenance-free Gel Battery
- Onboard Charger
- Tools Removable Broom
- Quiet Operation

Technical Specifications

Working Width	28.3 in (72 cm)
Main Broom	A.S.A.P. (All Surface All Purpose) broom designed for superior performance on all floor types.
Length	19.7 in (50 cm)
Diameter	7.9 in (20 cm)
Speed	335 rpm
Side Broom	
Diameter	12.4 in (31.5 cm)
Speed	100 rpm
Max Productivity @ 2.5 mph (4 km/hr)	31,200 ft ² (2,900 m ²)
Hopper Capacity	2.1 ft ³ (60 L)
Dust Filter	Polyester panel filter, 10.8 ft ² (1 m ²)
Motors	
Main broom/traction	0.3 hp (200 W)
Side broom	0.05 hp (40 W)
Vacuum fan	0.07 hp (50 W)
Power Source	(1) 12 V, 87 Ah maintenance free gel battery
Max Speed	2.5 mph (4 km/hr)
Drive System	Forward traction system capable of climbing 20% grade
Sound Level	59 dB A
Machine Weight (with battery)	171 lb (77.5 kg)
Battery Charger	Standard onboard, 12 V, 6 amp
Dimensions	Length = 39 in (99 cm) / Width = 31.5 in (80 cm) / Height = 24.4 in (62 cm)
Approvals	ETL, CSA, CE
Part Number	908 470 2010

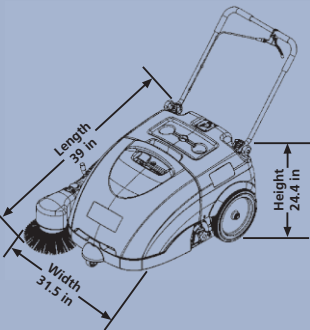

Specifications are subject to change without notice.



14600 21st Avenue North Plymouth, MN 55447-3408 www.advance-us.com Phone: 800-850-5559 Fax: 800-989-6566	396 Watline Avenue Mississauga, Ontario, Canada L4Z 1X2 www.nilfisk-advance.com Phone: 800-668-8400 or 905-712-3260 Fax: 800-263-5111 or 905-712-3255
--	---

©2007, Nilfisk-Advance, Inc., Printed in U.S.A., Form L3000A 7-07

