

Condor™

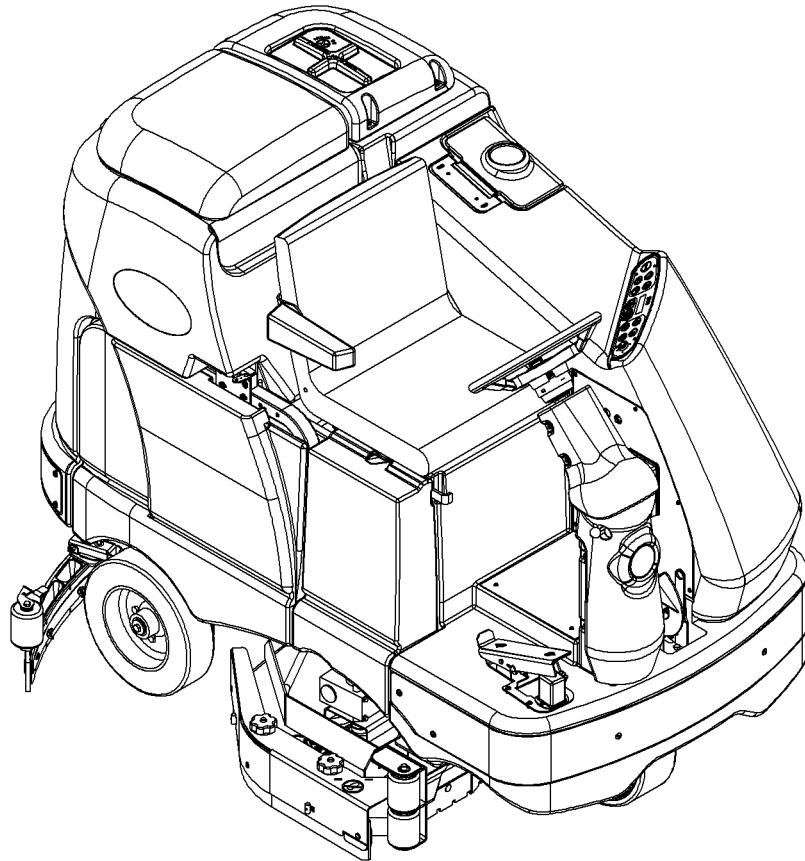

PARTS LIST

Models:

56413000(4030D), 56413001(4030C / w/sweep system), 56413891(4030C / w/o sweep system)
56413002(4530D), 56413003(4530C / w/sweep system), 56413892(4530C / w/o sweep system)
56413004(4830D), 56413005(4830C / w/sweep system), 56413893(4830C / w/o sweep system)
56413008(4030D-AXP), 56413009(4030C-AXP / w/sweep system), 56413894(4030C-AXP / w/o sweep system)
56413013(4530D-AXP), 56413014(4530C-AXP / w/sweep system), 56413895(4530C-AXP / w/o sweep system)
56413779(4830D-AXP), 56413780(4830C-AXP / w/sweep system), 56413896(4830C-AXP / w/o sweep system)



Advance
by Nilfisk-Advance

11/05 revised 11/08 FORM NO. 56042467

DESCRIPTION	PAGE
Chassis System	2-3
Decal System	4-5
Drive Wheel System.....	6-7
Drive Wheel System (steering assembly)	8-9
Electrical System.....	10-11
Rear Wheel System	12-13
Recovery System	14-15
Scrub System-Cylindrical	16-17
Scrub System-Cylindrical (scrub assembly).....	18-19
Scrub System-Cylindrical (skirt/bumper assemblies).....	20-21
Scrub System-Disk.....	22-23
Scrub System-Disk (40" scrub assembly).....	24-25
Scrub System-Disk (45", 48" scrub assembly).....	26-27
Scrub System-Disk (skirt assemblies).....	28-29
Solution System	30-31
Solution System (chemical metering kit).....	32-33
Solution System (drive pedal/electrical panel assy's)	34-35
Squeegee System.....	36-37
Squeegee System (squeegee arm assembly)	38-39
Squeegee System (squeegee assembly 40").....	40-41
Squeegee System (squeegee assembly 45", 48").....	42-43
Sweep System	44-45
Sweep System (side broom assemblies).....	46-47
Wiring Diagram	48-49
Brush Selector Guide-Disk.....	50
Brush Selector Guide-Cylindrical	51
Optional Kit and Accessories	52-53

WHEN ORDERING PARTS

- * Use the numbers from the "Ref. No." columns in this parts list.
- * Specify the model and serial number of the machine.
- * Use the space below to record the model and serial number for future reference.

Model _____ Serial No. _____

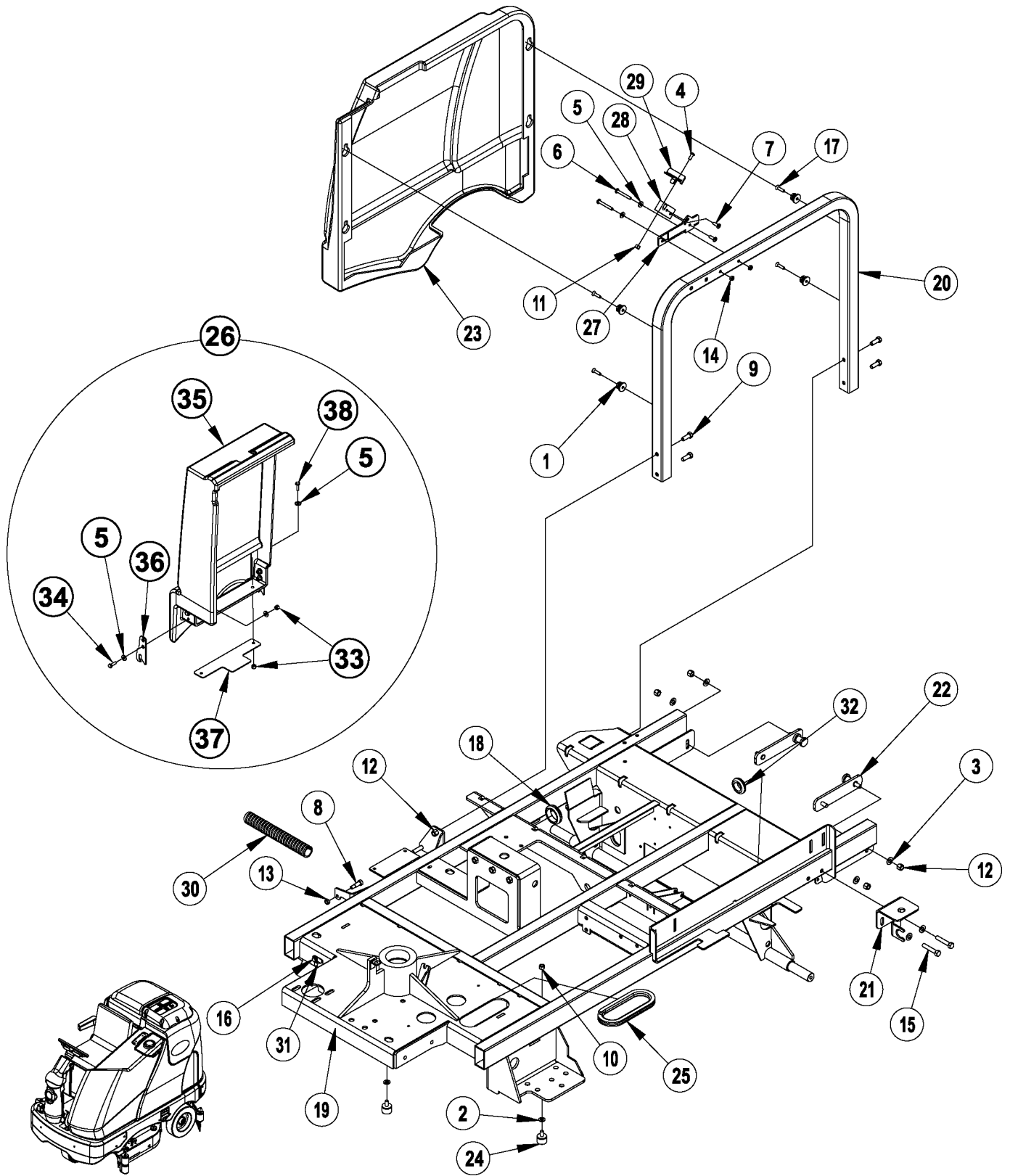

05-11

CHASSIS SYSTEM

08-5

Condor™**3**

Item	Ref. No.	Qty	Description
1	56365777	4	Lug, Brush Driver
2	56001939	2	Wsh, Flt SAE 5/16
3	56002063	6	Wsh, Flt SAE 3/8
4	56002066	1	Scr, Pan Phil 1/4-20 X .62
5	56002098	2	Wsh, Flt SAE 1/4
6	56002108	2	Scr, Pan Phil 1/4-20 X 2.00
7	56002507	2	Scr, Pan Phil 1/4-20 X .75
8	56002622	1	Scr, Soc Shd .38 X .75 X 5/16-18
9	56002663	4	Scr, Hex 3/8-16 X 1.00
10	56002701	2	Nut, Hex Nyl Loc 5/16-18
11	56002708	1	Nut, Hex Nyl Loc 1/4-20
12	56002769	8	Nut, Hex Nyl Loc 3/8-16
13	56002826	1	Nut, Hex Nyl Loc-Thin 5/16-18
14	56002840	2	Nut, Hex Nyl Loc-Thin 1/4-20
15	56003031	2	Scr, Hex Hd Loc 3/8-16x2.00
16	56009033	1	Scr, Hex Thd Form 1/4-20 X .50
17	56009101	4	Scr, Flt Phil Thd Form 1/4-20x1.00
18	56054715	1	Grommet
19	56413035	1	Weld't, Chassis
20	56413252	1	Support, Chassis
21	56413254	1	Support
22	56413373	2	Pin Plate Weldt
23	56413386	1	Panel, Side Rear
24	56413714	2	Bumper, Rubber
25	56413724	1	Trim, Edge
26	56413795	1	Side Panel Assy (#33-37)
27	56413798	1	Plate, Latch Mount
28	56413802	1	Latch, RH
29	56413843	1	Lever
30	56413847	1	Conduit
31	56486112	1	Clamp, P
32	56486116	1	Grommet
33	56003403	6	Nut, Hex Nyl Loc M6-1
34	56003454	6	Scr, Hex Thd To Hd SS M6-1 X 20mm
35	56413387	1	Panel, Side Front
36	56413433	2	Hinge
37	56413796	1	Plate

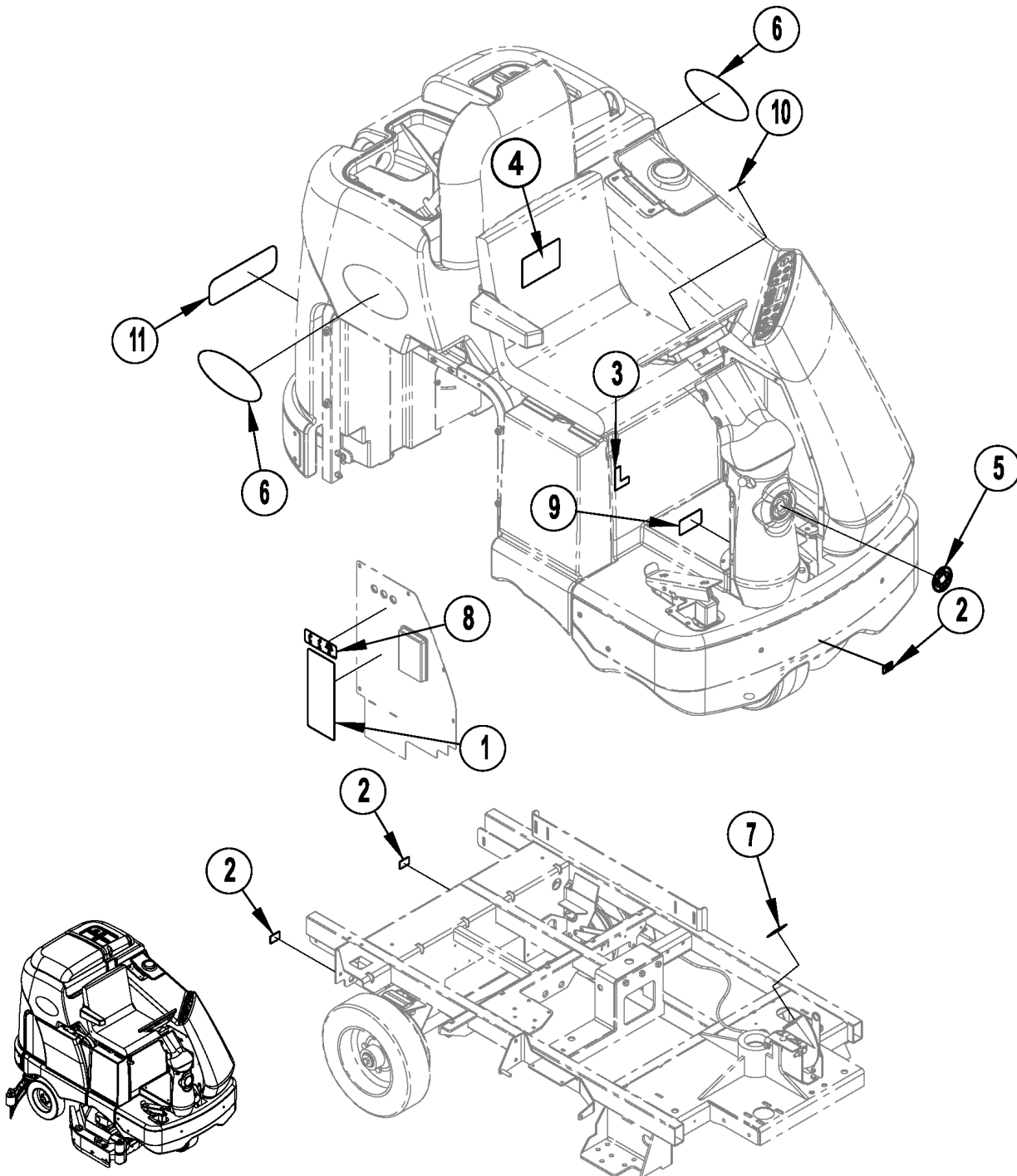

05-11

DECAL SYSTEM

08-5

Condor™

5

Item	Ref. No.	Qty	Description
1	56014601	1	Decal, Caution
2	56015370	3	Decal, Tie Down
3	56015179	1	Decal, Emergency
4	56015272	1	Decal, Battery Wiring Diagram
5	56015276	1	Decal, Logo
6	56016735	2	Decal, Condor
	56016736	2	Decal, Condor AXP
7	56413797	1	Mat, Pedal
8	56015374	1	Decal, Circuit Breaker
9	56016401	1	Decal, Parking Brake
10	56015281	1	Decal, Logo 2 Inch
11	56016730	1	Decal, Advance

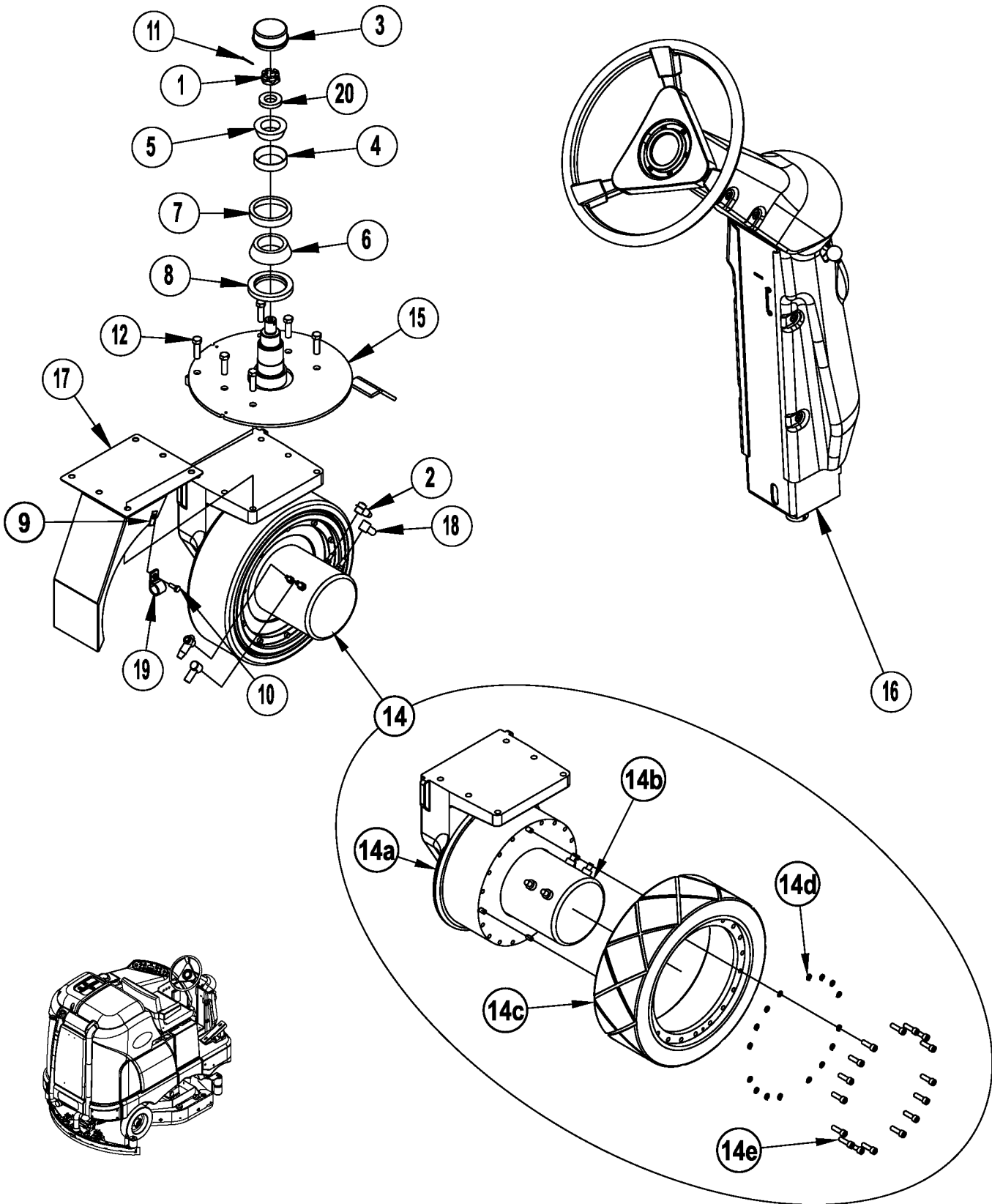

05-11

DRIVE WHEEL SYSTEM

08-11

Condor™**7**

Item	Ref. No.	Qty	Description
1	56110817	1	Nut, Castle 7/8-14
2	56409538	2	Insulator, Terminal
3	56483135	1	Cap, Grease
4	56492697	1	Bearing, Cup
5	56492699	1	Bearing, Cone
6	56492700	1	Bearing, Cone
7	56492702	1	Bearing, Cup
8	56493191	1	Seal, Radial Lip
9	56009289	1	Nut, Retainer 1/4-20
10	56002155	1	Scr, Hex 1/4-20 X .75
11	56002181	1	Pin Cotter, 1/8 X 1 1/2
12	56003743	6	Scr, Hex 7/16-14 X 1.75
14#	56413885	1	Wheel Drive Assy
14a	56102257	1	Drive Motor Assy TSBUS2007-971
14b	56413615	1	Motor, Traction (M1)
*#	56413616	1	Carbon Brush Set
*#			DELETED
*#			DELETED
14c#	56380443	1	Poly Front Wheel
14d	56003781	16	Wsh, High Collar Lock 5/16
14e	56003203	16	Scr, Soc Hd 5/16-18 x 1.00
15	56413160	1	Front Spindle Weld't
16	56413174	1	Steering Assy
17	56413178	1	Splash Guard
18	56492305	2	Boot, Rubber
19	56496276	1	Clamp, Hose Support
20	56497241	1	Bushing

* = Not Shown

** = Optional (Not Included)

= Revised or new since last update

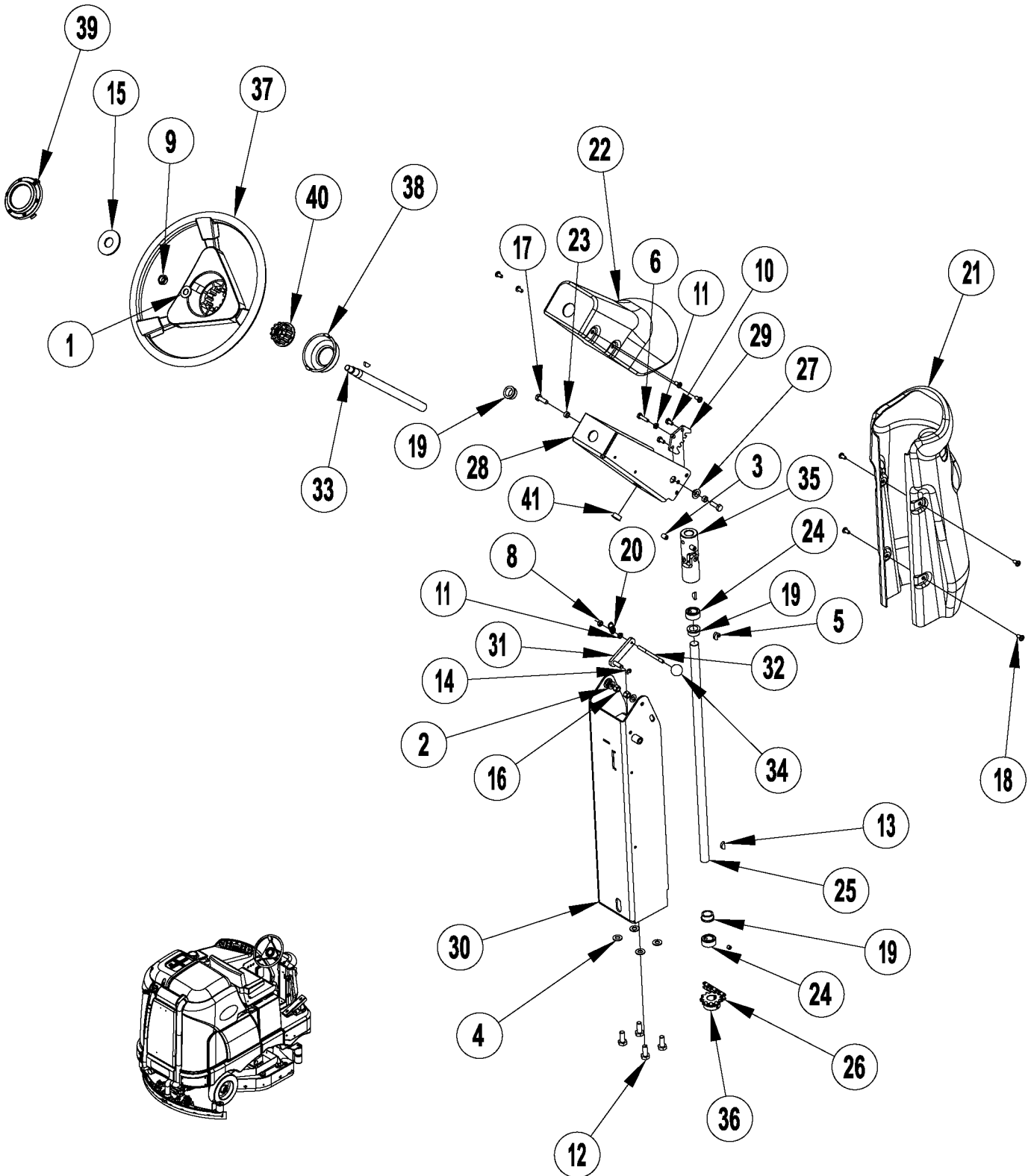

05-11

DRIVE WHEEL SYSTEM (steering assembly)

08-5

Condor™**9**

Item	Ref. No.	Qty	Description
1	56001879	1	Wsh, Flt SAE 1/2
2	56001939	2	Wsh, Flt SAE 5/16
3	56001958	2	Scr, Soc Set Loc 3/8-16 x .50
4	56002063	4	Wsh, Flt SAE 3/8
5	56002086	2	Scr, Soc Set Loc 5/16-18 x .25
6	56002093	1	Scr, Hex 1/4-20 x 1.00
8	56002840	1	Nut, Hex Nyl Loc-Thin 1/4-20
9	56002843	1	Nut, Hex Nyl Loc-Thin 1/2-13
10	56002933	2	Scr, Hex Hd Loc 1/4-20 x .38 (before serial number 1926681)
	56003039	2	Scr, Hex Hd Loc 1/4-20 x .50 (after serial number 1926680)
11	56003145	2	Nut, Hex Jam SS 1/4-20
12	56003186	4	Scr, Hex Thd To Hd M10-1.5 x 25mm
13	56003228	4	Key, Wdf .75 x .19
14	56003261	1	Ring, Ret Ext Type E 0.31 Dia
15	56003342	1	Washer Flt .88 x 2.25 x .13
16	56003389	2	Nut, Hex Nyl Loc M8-1.25
17	56003436	2	Scr, Hex SS M8-1.25 x 25mm
18	56009062	8	Scr, Pan Phil Thd Form 1/4-20 x .50
19	56250414	3	Bearing, Flange
20	56305072	1	Spring, Extension .075
21	56314295	1	Shroud, Lower Column
22	56314296	1	Shroud, Upper Column
23	56320595	2	Bushing .32 x .50 x .28
24	56367095	2	Collar, Shaft
25	56413175	1	Shaft, Lower Steering
26	56412198	1	Chain, Roller
27	56413211	2	Bearing, Flange .625 x .500 x .250
28	56413657	1	Column, Upper
29	56413658	1	Ratchet, Steering Column
30	56413659	1	Lower Column Weldment
31	56413661	1	Steering Pawl Weldment
32	56413664	1	Rod
33	56420059	1	Shaft, Upper Steering
34	56440817	1	Knob
35	56454081	1	Universal Joint
36	56471148	1	Sprocket
37	56497306	1	Steering Wheel
38	56497308	1	Cup
39	56497543	1	Cap
40	56497560	1	Wheel Adapter
41	56900041	1	Plug, Cap

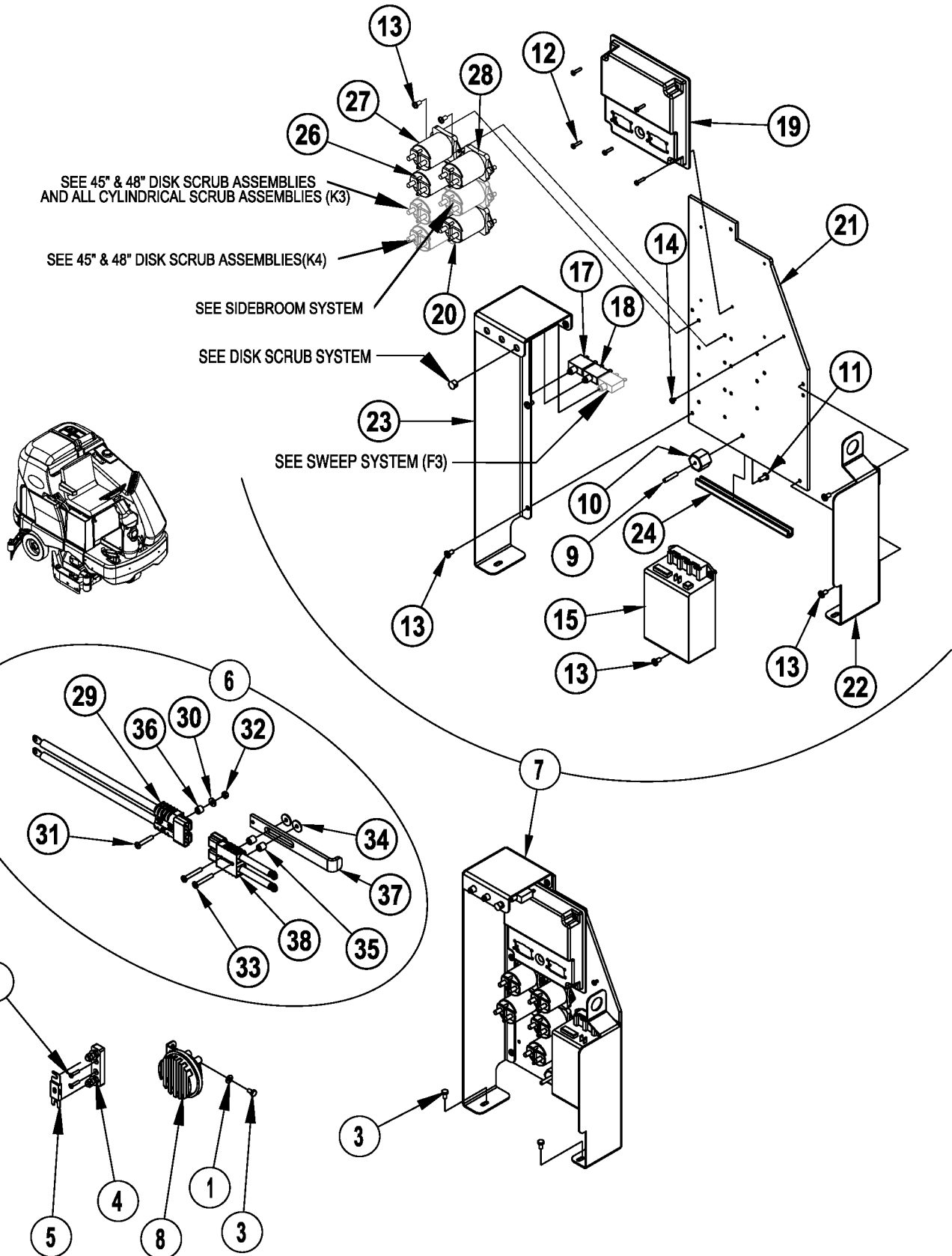

Item	Ref. No.	Qty	Description
1	56002098	1	Wsh, Flt SAE 1/4
2	56002417	2	Scr, Flt Phil 10-24 X .88
3	56009033	3	Scr, Hex Thd Form 1/4-20 X .50
4	56303295	1	Fuse Block
5	56410044	1	Fuse, 250 Amp (F4)
6	56413067	1	Disconnect, Battery (#29-38)
7	56413631	1	Electrical Component Assembly (#9-28)
8	56482365	1	Horn 36v (H4)
9	56009203	1	Stud, 1/4-20
10	56469858	1	Electrical Mount
11	56002066	1	Scr, Pan Phil 1/4-20 X .62
12	56003698	5	Scr, Pan Phil Thd Form 8-32 X .75
13	56009033	18	Scr, Hex Thd Form 1/4-20 X .50
14	56009030	1	Scr, Pan Phil Thd Form 10-24 X .38
15	56413041	1	Controller, 36vdc (A1)
16			Deleted Intentionally
17	56413406	1	Circuit Breaker, 3.0 Amp (Control / F1)
18	56413407	1	Circuit Breaker, 15 Amp (Auxiliary / F2)
19	56413483	1	Main PCB Box Assembly (A2)
20	56413516	1	Contact, 36vdc 200a (Main / K7)
21	56413622	1	Mount, Electrical
22	56413623	1	Mount, Electrical Panel
23	56413627	1	Mount, Electrical
24	56413841	1	Edge Trim, .25
26	56413516	1	Contact, 36vdc 200a (Right Brush / K2)
27#	56413516	1	Contact, 36vdc 200a (Vacuum / K1) TSBUS2008-996
28#	56413516	1	Contact, 36vdc 200a (Auxiliary / K5) TSBUS2008-996
29	56409444	1	Connector Assy
30	56002098	1	Wsh, Flt SAE 1/4
31	56002786	1	Scr, Pan Phil 1/4-20 X 1.50
32	56002840	1	Nut, Hex Nyl Loc-Thin 1/4-20
33	56002997	2	Scr, Pan Phil 1/4-20 X 1.75
34	56009002	2	Wsh, Flt .266 X .906 X .060
35	56046309	2	Spacer, Phenolic
36	56050872	1	Spacer, Phenolic
37	56413132	1	Bar, Disconnect
38	56413217	1	Connector Assy
*	56409485	5	Cable, Battery
*	56413215	1	Main, Harness TSBUS2008-986
*	56413883	5	Ferrite Bead (Found on Main harness)
*	56413881	1	Ferrite Bead (Found on Main Harness)
*	56413216	1	Harness, Traction Motor
*	56413219	1	Cable Asm, Blk 4-1
*	56413220	1	Cable Asm, Red 1-3
*	56413221	1	Cable Asm, Red 6-1
*	56413222	1	Cable Asm, Red 4-1
*	56478246	5	Tie, Cable
*	56477613	20	Tie, Cable

* = Not Shown

= Revised or new since last update

REAR WHEEL SYSTEM

05-11

12

Condor™

06-8

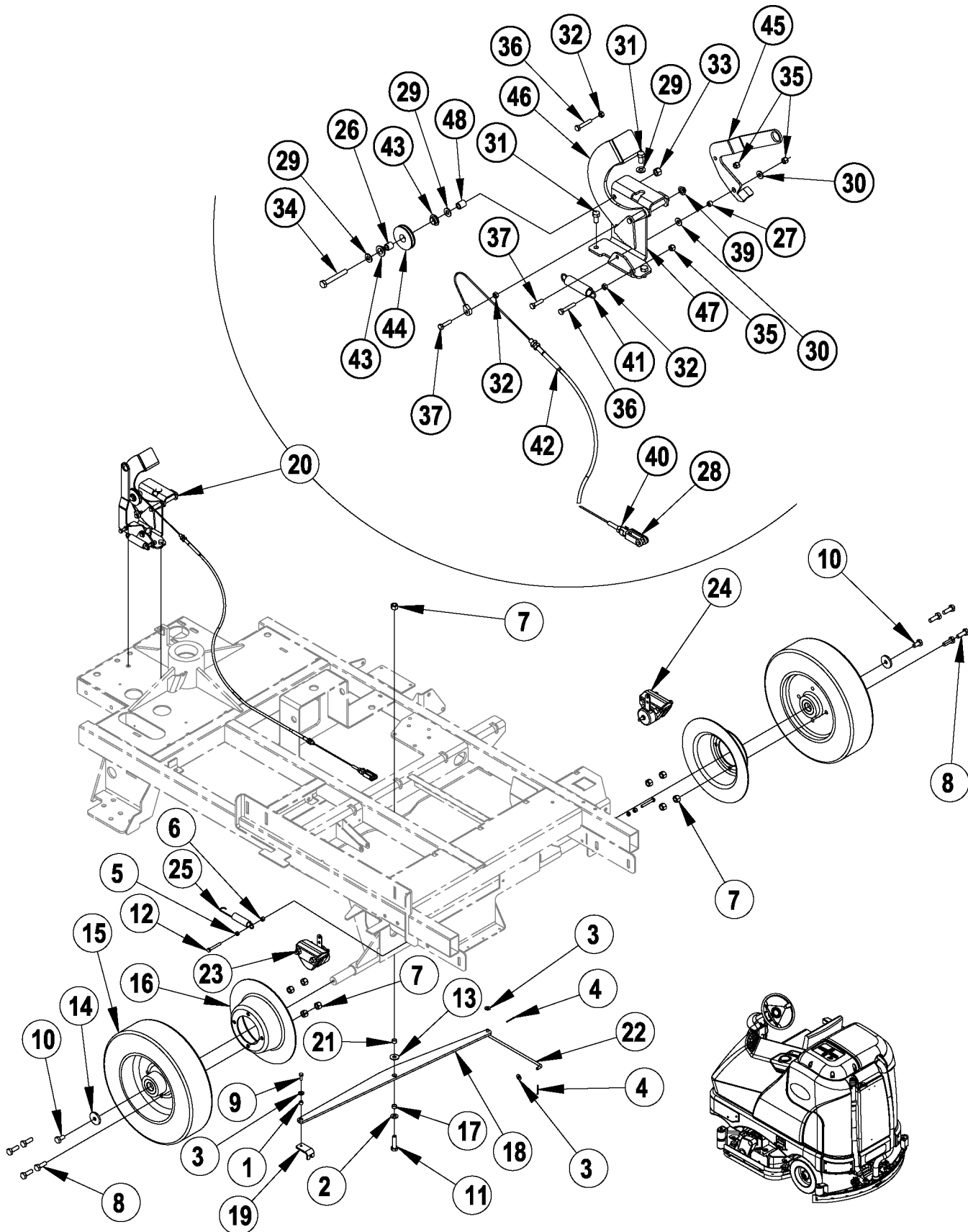

Item	Ref. No.	Qty	Description
1	56453849	1	Bushing .26 x .37 x .28
2	56002063	1	Wsh, Flt SAE 3/8
3	56002098	3	Wsh, Flt SAE 1/4
4	56001882	2	Pin, Cotter 1/16 x 3/4
5	56003350	2	Nut, Hex M6-1 TSBUS2006-936 / NOTE 1
6	56003403	2	Nut, Hex Nyl Loc M6-1 TSBUS2006-936 / NOTE 1
7	56003406	9	Nut, Hex Nyl Loc M10-1.5
8	56003439	8	Scr, Hex SS M10-1.5 x 30mm
9	56003441	1	Scr, Hex Loc M6-1 x 16mm
10	56003442	2	Scr, Hex Loc M10-1.5 x 20mm
11	56003491	1	Scr, Hex M10-1.5 x 40mm
12	56003631	2	Scr, Hex M6-1 x 45mm TSBUS2006-936 / NOTE 1
13	56009213	1	Wsh, Flt .392 x 1.00 x .075
14	56367117	2	Wsh, Flt .406 x 1.5 x .1875
15	56413292	2	Wheel, Rear
*	56412243	A/R	Ball Bearing for 56413292 (2 per wheel)
16	56413293	2	Rotor
17	56413498	1	Spacer, .390 x .500 x .280
18	56413500	1	Equalizer
19	56413501	1	Yoke
20	56413533	1	Brake Pedal Assy (#26-48)
21	56413552	1	Bushing.410 x .50 x .30
22	56413598	1	Linkage, Brake
23	56413025	1	Brake-CW TSBUS2006-936 / TSBUS2007-970
24	56413024	1	Brake-CCW TSBUS2006-936 / TSBUS2007-970
25	56413812	2	Spring, Extension TSBUS2006-936
26	56228052	1	Bushing
27	56413888	1	Bushing
28	56407133	1	Yoke, Clevis
29	56001939	3	Wsh, Flt SAE 5/16
30	56002098	2	Wsh, Flt SAE 1/4
31	56002929	3	Scr, Hex Hd Loc 5/16-18 x .62
32	56003350	3	Nut, Hex M6-1
33	56003389	1	Nut, Hex Nyl Loc M8-1.25
34	56003398	1	Scr, Hex M8-1.25 x 60mm
35	56003403	3	Nut, Hex Nyl Loc M6-1
36	56003420	2	Scr, Hex M6-1 x 35mm
37	56003430	2	Scr, Hex SS M6-1 x 25mm
38			Intentionally Omitted
39	56009123	1	Nut, Push Cap 3/8
40	56009142	1	Nut, Hex Machine 1/4-28
41	56397348	1	Spring, Extension
42	56413208	1	Cable Assy
43	56413211	2	Bearing, Flange .625 x .500 x .250
44	56413508	1	Pulley
45	56413527	1	Pawl
46	56413534	1	Brake Pedal Weld't.
47	56413538	1	Bracket, Brake Pedal
48	56413787	1	Spacer

NOTE 1: Machines built after serial number 1959307 have a modified chassis which eliminates the need for these hardware items.

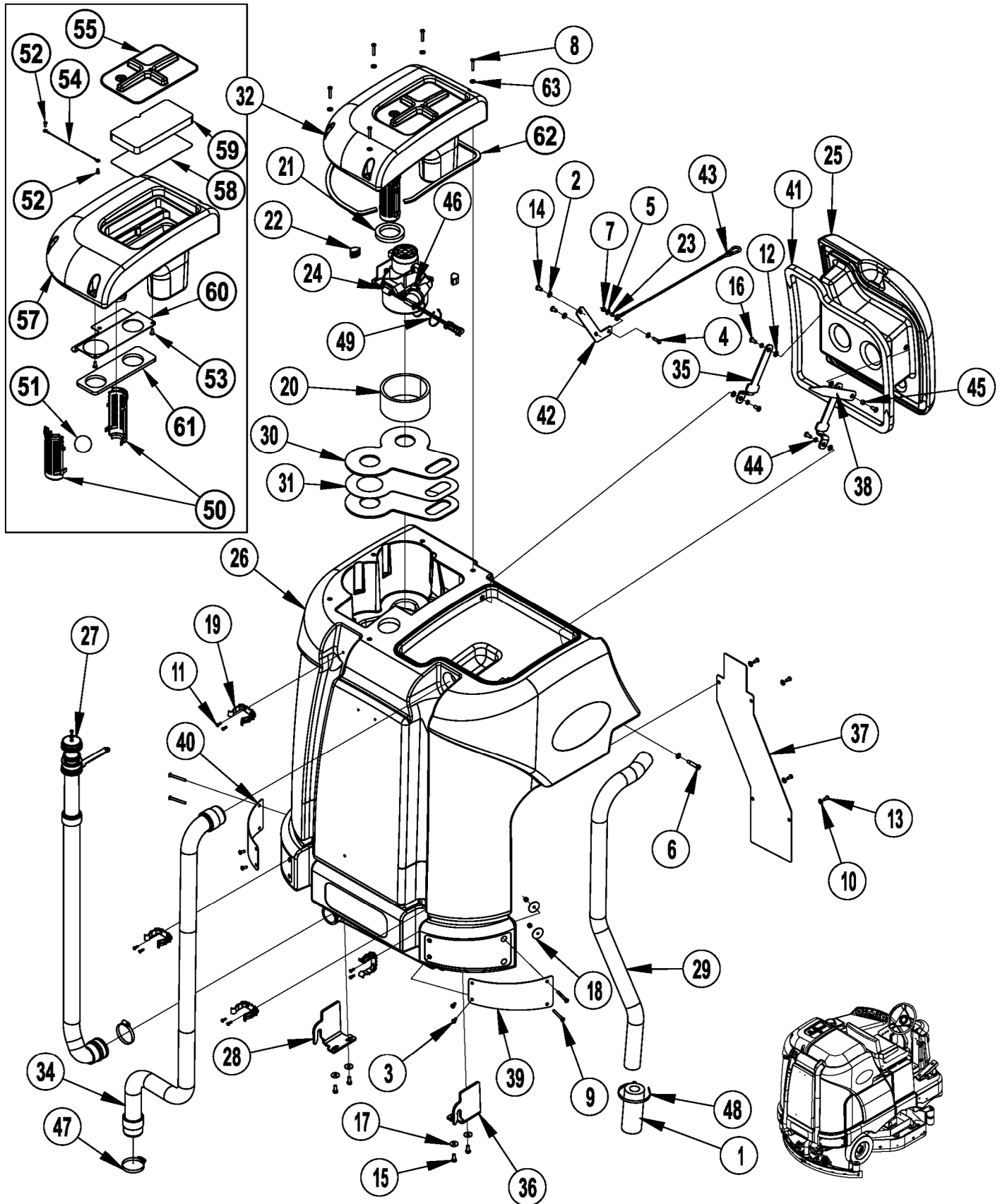

Item	Ref. No.	Qty	Description	Item	Ref. No.	Qty	Description
1	56391807	1	Foam, Acoustical	32	56413196	1	Top Cover Assy (50-61)
2	56001939	3	Wsh, Flt SAE 5/16	33	56413218	1	Harness, Recovery Tank
3	56002066	4	Scr, Pan Phil 1/4-20 x .62	34	56413377	1	Hose, Squeegee Vac
4	56002507	1	Scr, Pan Phil 1/4-20 x .75	35	56413404	2	Arm, Lid Hinge
5	56002098	2	Wsh, Flt SAE 1/4	36	56413555	1	Hinge Plate, Right
6	56002624	1	Scr, Soc Shd .38 x 1.25 x 5/16-18	37	56413577	1	Panel, Exhaust
7	56002708	5	Nut, Hex Nyl Loc 1/4-20	38	56413589	1	Prop
8	56002786	5	Scr, Pan Phil 1/4-20 x 1.50	39	56413606	1	Bumper, Right Rear
9	56002788	4	Scr, Pan Phil 1/4-20 x 2.25	40	56413607	1	Bumper, Left Rear
10	56002859	4	Wsh, Flt SAE SS 1/4	41	56413699	1	Gasket, Recovery Lid
11	56002896	8	Scr, Pan Phil SS 10-24 x .62	42	56413458	1	Plate, Cable Mount
12	56002938	4	Wsh, Flt SAE SS 5/16	43	56413723	1	Cable Assembly
13	56002989	4	Scr, Pan Phil SS 1/4-20 x .62	44	56413800	3	Bushing .32x.50x.18
14	56003003	2	Scr, Pan Phil 5/16-18 X .62	45	56413801	1	Bushing .32x.50x.35
15	56003012	4	Scr, Hex SS 5/16-18 X .75	46	56440213	1	Clamp, Hose SAE #32
16	56003014	4	Scr, Pan Phil Ss 5/16-18 X .75	47	56456797	2	Clamp, Hose SAE #36
17	56003696	4	Wsh, Flt SS .33 X 1.00 X.060	48	56477613	1	Tie, Cable
18	56009225	4	Wsh, Fender .281x1.50x.074	49	56478246	1	Tie, Cable
19	56212236	4	Clamp, Plastic	50	56324497	2	Cage, Float
20	56314488	1	Muffler, Vac	51	56391690	1	Ball, Float
21	56314760	1	Gasket, Vacuum Duct	52	56009191	2	Scr, Pan Phil Plastite 10-14 X .50
22	56315141	2	Mount, Vibration	53	56009210	2	Scr, Pan Phil Type B 1/4-14 X .62
23	56368989	1	Bushing	54	56314400	1	Wire Rope, 9 Inch
24	56410065	1	Vac Motor Assy (M5)	55#	56109539	1	Vac Filter Lid NOTE 1
25	56413091	1	Lid, Recovery Tank	56#			DELETED
26	56413150	1	Tank, Recovery	57	56413155	1	Top, Recovery Tank
27	56601408	1	Drain Hose	58	56413194	1	Screen, Filter
*	56601411	1	Drain Hose Cap Kit	59	56413195	1	Filter
28	56413163	1	Mount, Recovery Tank	60	56413408	1	Plate, Vac Cover
29	56413171	1	Hose, Vac 2.00 X 42.00 X 975018	61	56413416	1	Gasket, Vac Fan Top
30	56413187	2	Gasket, Vac Fan	62	56413846	1	Gasket, RS Strip
31	56413191	1	Plate, Vac Fan	63	56009002	5	Wsh, Flt .266 x .906 x .060

= Revised or new since last update

NOTE 1: 56314461 and 56314491 are no longer used in production. If you need to replace either of these items please order 56109539.

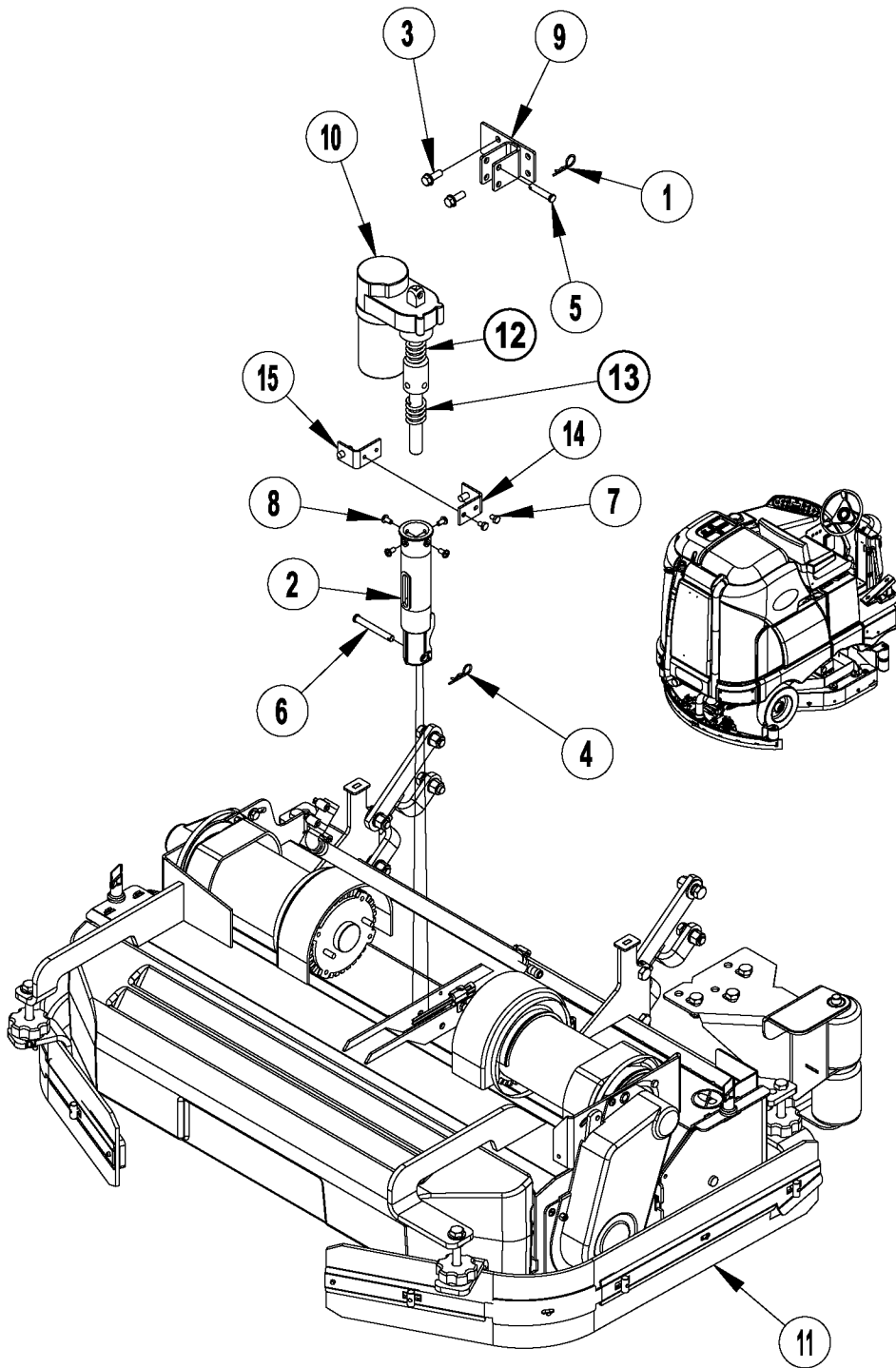

05-11

SCRUB SYSTEM-CYLINDRICAL

08-5

Condor™**17**

Item	Ref. No.	Qty	Description
1	56002959	1	Pin, Cotter Hair
2	56412262	1	Housing, Spring
3	56002256	2	Scr, Hex Type 1 3/8-16 X 1.00
4	56003120	1	Pin, Cotter Hair .0915 X .375
5	56003597	1	Pin, Clevis .375 X 1.75
6	56003704	1	Pin, Clevis .38 X 3.00
7	56009019	2	Scr, Hex Thd Form 1/4-20 X .38
8	56009062	4	Scr, Pan Phil Thd Form 1/4-20 X .50
9	56413455	1	Mount Weldment
10	56413700	1	Actuator (M2)
11	56413788	1	40" Cyl Scrub Assembly
	56413790	1	45" Cyl Scrub Assembly
	56413792	1	48" Cyl Scrub Assembly
12	56413828	1	Spring, Upper Housing
13	56413829	1	Spring, Lower Housing
14	56420019	1	Nut Retainer
15	56420020	1	Nut Retainer

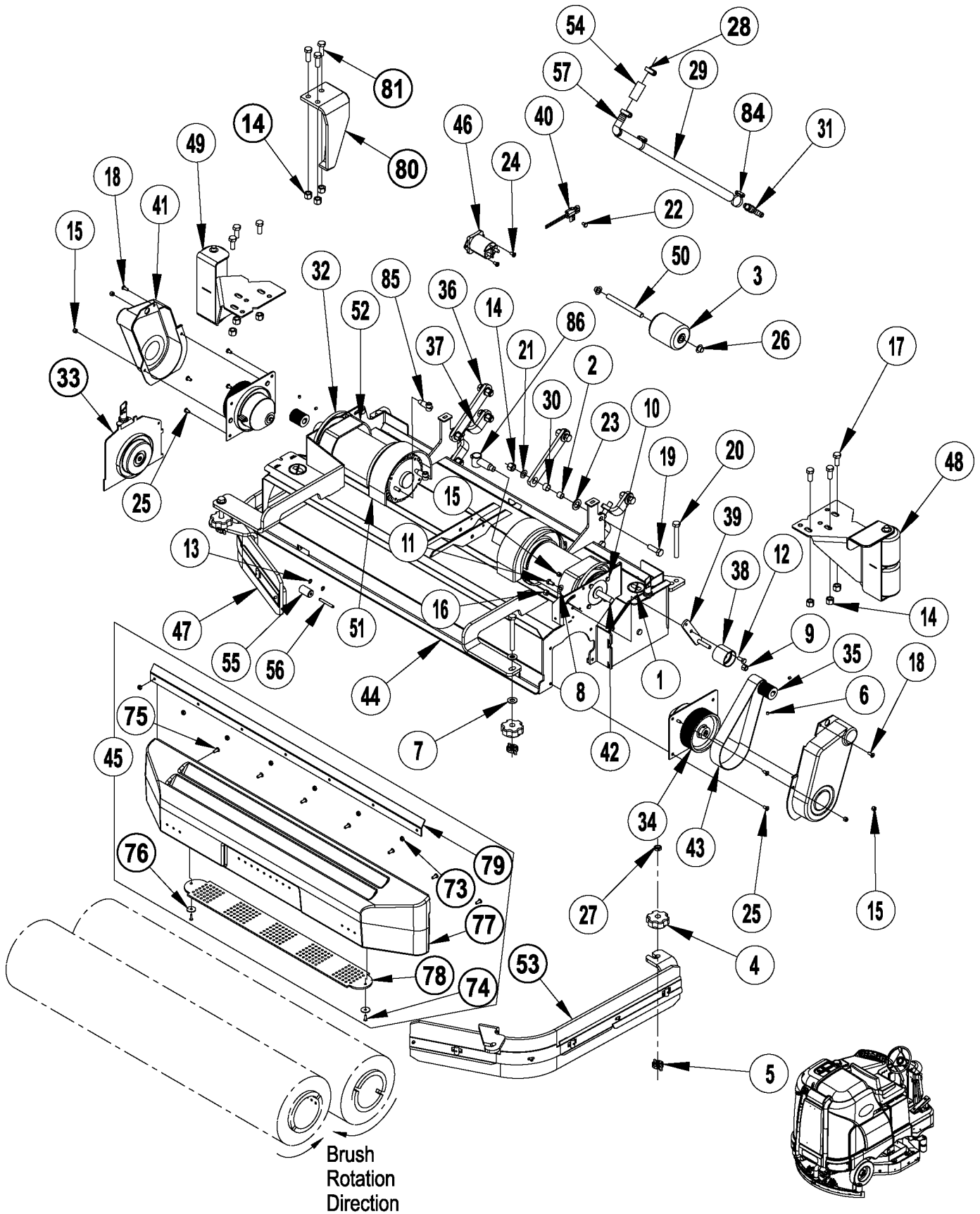

Item	Ref. No.	Qty	Description	Item	Ref. No.	Qty	Description
	56413788	1	40" Cyl Scrub Assembly	44	56413247	1	Cyl Scrub Deck Weld't-40 (40")
	56413790	1	45" Cyl Scrub Assembly		56413440	1	Cyl Scrub Deck Weld't-45 (45")
	56413792	1	48" Cyl Scrub Assembly		56413344	1	Cyl Scrub Deck Weld't-48 (48")
1	56016163	2	Decal, No Step	45	56413331	1	Hopper Assembly-40 (40") (73-79)
2	56367206	8	Bushing		56413443	1	Hopper Assembly-45 (73-79)
3	56407006	2	Wheel, Roller		56413346	1	Hopper Assembly-48 (48") (73-79)
4	56407114	4	Knob	46	56413516	1	Contact, 36vdc 200A (K3)
5	56407334	4	Knob	47	56413871	1	Left Skirt Assembly (40")
6	56001841	4	Scr, Soc Set Loc 1/4-20 X .25		56413556	1	Left Skirt Assembly (45" & 48")
7	56001879	4	Wsh, Flt SAE 1/2	48	56413578	1	Right Guard Assy
8	56002063	2	Wsh, Flt SAE 3/8	49	56413584	1	Left Guard Assy (45" & 48")
9	56002769	2	Nut, Hex Nyl Loc 3/8-16	50	56413596	2	Pin
10	56002922	8	Scr, Hex Hd Loc 1/4-20x.62	51	56413604	2	Shield, Water
11	56003178	2	Scr, Hex M8-1.25 X 16mm	52	56413605	2	Shield, Water
12	56003179	2	Scr, Hex Thd To Hd M8-1.25 X 20mm	53	56413609	1	Right Skirt Assembly
13	56003268	4	Ring, Ret Ext Type E Reinf. 0.25 Dia	54	56413813	1	Hose, .75 Clear Pvc
14	56003312	14	Nut, Hex Nyl Loc M12-1.75	55	56413817	2	Roller, Rear
15	56003403	6	Nut, Hex Nyl Loc M6-1	56	56413818	2	Pin
16	56003405	2	Nut, Hex Nyl Loc SS M8-1.25	57	56900272	1	Barb, 3/4 90 Deg. Elbow
17	56003418	6	Scr, Hex M12-1.75 X 30mm	58	56370711	1	Nut, Thumb
18	56003627	2	Scr, Pan Phil M6-1 X 16mm	59	56009199	1	Wsh, Flt Brass .266 x 1.250 x .125
19	56003637	8	Scr, Hex M12-1.75 X 40mm	60	56009069	1	Scr, Pan Phil Loc 1/4-20 X .50
20	56003707	4	Scr, Hex Thd To Hd M12-1.75 X 110mm	61	56479430	1	Bearing, Ball
21	56009017	8	Wsh, Flt Harden .516x.938 X.75	62	56413267	1	Broom Hanger Weldt
22	56009019	1	Scr, Hex Thd Form 1/4-20 X .38	63#	56109504	1	Idler, Brush TSBUS2007-975
23	56009022	8	Wsh, Flt .754 X 1.250 X .120	64	56003155	1	Scr, Hex M6-1 X 12mm
24	56009062	2	Scr, Pan Phil Thd Form 1/4-20 X .50	65	56003238	2	Key, Sq, 19 X .78
25	56009069	8	Scr, Pan Phil Loc 1/4-20 X .50	66	56009060	1	Wsh, Flt SS .260 X 1.000 X .074
26	56009097	4	Nut, Push Cap 1/2	67	56002930	2	Scr, Soc Set Loc 1/4-20 X .38
27	56009258	4	Nut, Hex Jam M12-1.75	68	56303050	2	Bearing, Ball
28	56112771	4	Clamp, Hose SAE #10	69	56413276	1	Broom Hanger Weldt
29	56303394	1	Hose, Spiral .75 x 25.00	70	56413284	1	Sheave, Poly V
30	56304586	8	Bearing, 750 X .625 X .500	71	56413620	1	Shaft, Broom Drive Lug
31	56305760	1	Tee, Barb 3/4 X 1/2 X 1/2	72	56413635	1	Drive Lug
32	56355488	4	Clamp, Hose SAE #96	73	56002850	7	Nut, Hex Nyl Loc-Thin Ss 1/4-20
33	56413269	2	Broom Idler Assy (58-63, 83)	74	56002896	2	Scr, Pan Phil SS 10-24 X .62
34	56413275	2	Broom Drive Lug Assy (64-72, 82)	75	56002989	7	Scr, Pan Phil SS 1/4-20 X .62
35	56413285	2	Sheave, Poly V	76	56009060	2	Wsh, Flt SS .260 X 1.000 X .074
36	56413302	2	Arm Parallel 6 In	77	56413333	1	Hopper, 40 In. (40")
37	56413303	2	Arm, Adjustable Assy		56413444	1	Hopper, 45 In. (45")
38	56413324	2	Idler		56413348	1	Hopper, 48 In. (48")
39	56413325	2	Tensioner Weld't	78	56413338	1	Screen, Hopper-40 In. (40")
40	56413393	1	Resistor Assy, 10k Ohm (40" / R2)		56413446	1	Screen, Hopper-45 In. (45")
	56413391	1	Resistor Assy, 40k Ohm (45" & 48" / R2)		56413349	1	Screen, Hopper-48 In. (48")
41	56413395	2	Guard, Belt	79	56413339	1	Threshold, Hopper-40 In. (40")
42	56413398	2	Motor, 36vdc 1.5 Hp (M9 / M10)		56413447	1	Threshold, Hopper-45 In. (45")
*	56413628	1	Brush & Spring Kit		56413350	1	Threshold, Hopper-48 In. (48")
43	56413419	2	Belt, 260j16	80	56413831	1	Roll Bar Weld't. (40")
				81	56003415	3	Scr, Hex M12-1.75 x 35mm (40")
				82	56413877	1	Spacer
				83	56003314	1	Ring, Retainer
				84	56244969	1	Clamp, Hose SAE #12
				85	56409538	3	Insulator, Terminal
				86	56493357	1	Insulator, Terminal

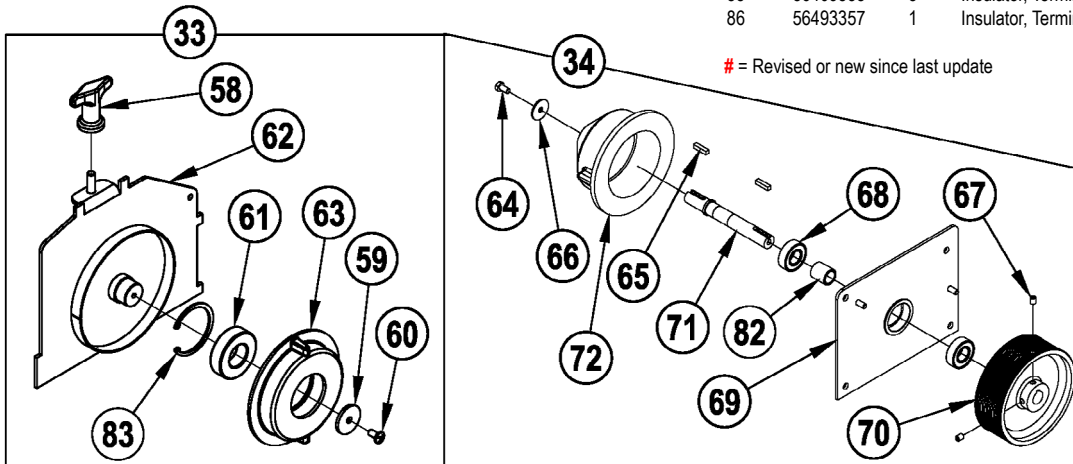

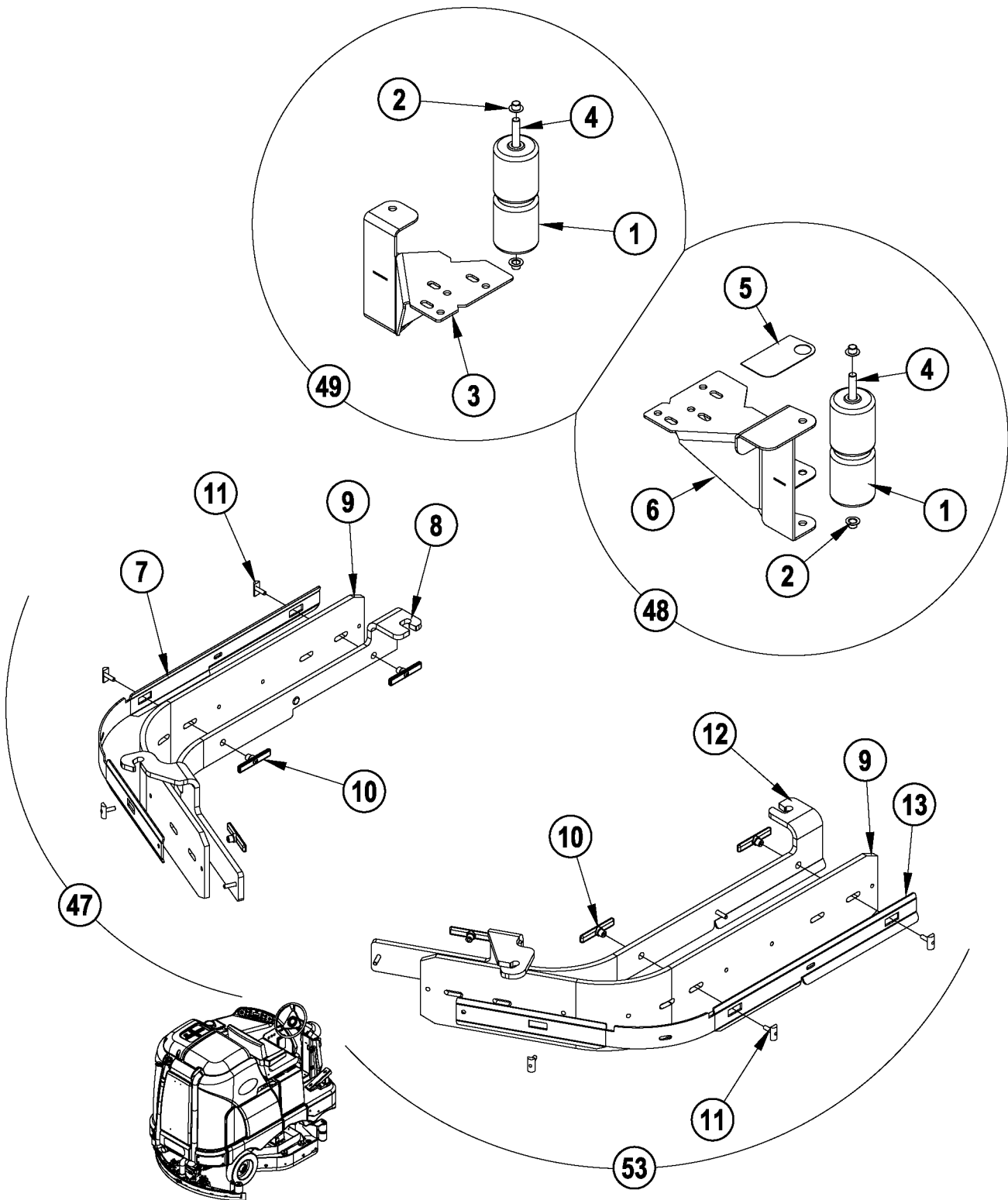

05-11

SCRUB SYSTEM-CYLINDRICAL (skirt / bumper assemblies)

08-5

Condor™

21

Item	Ref. No.	Qty	Description
47	56413871	1	Left Skirt Assembly (#7-11 / 40") Page 18
47	56413556	1	Left Skirt Assembly (#7-11 / 45" & 48") Page 18
48	56413578	1	Right Guard Assy (#1, 2, 4, 5, 6) Page 18
49	56413584	1	Left Guard Assy (#1-4 / 45" & 48") Page 18
53	56413609	1	Right Skirt Assembly (#9-13) Page 18
1	56407006	4	Wheel, Roller
2	56009097	4	Nut, Push cap 1/2
3	56413571	1	Left guard Weld't.
4	56413590	2	Pin
5	56413721	1	Grip Surface
6	56413837	1	Right Guard Weld't.
7	56413860	1	Strap, Skirt-LT
8	56413872	1	Left Bracket Weld't.-40" (40")
	56413858	1	Left Bracket Weld't.-45" & 48" (45" & 48")
9	56413654	2	Skirt
10	56413717	6	Thumb Nut
11	56413850	6	Skirt Retainer Assy
12	56413854	1	Right Bracket Weld't.
13	56413857	1	Strap, Skirt-RT

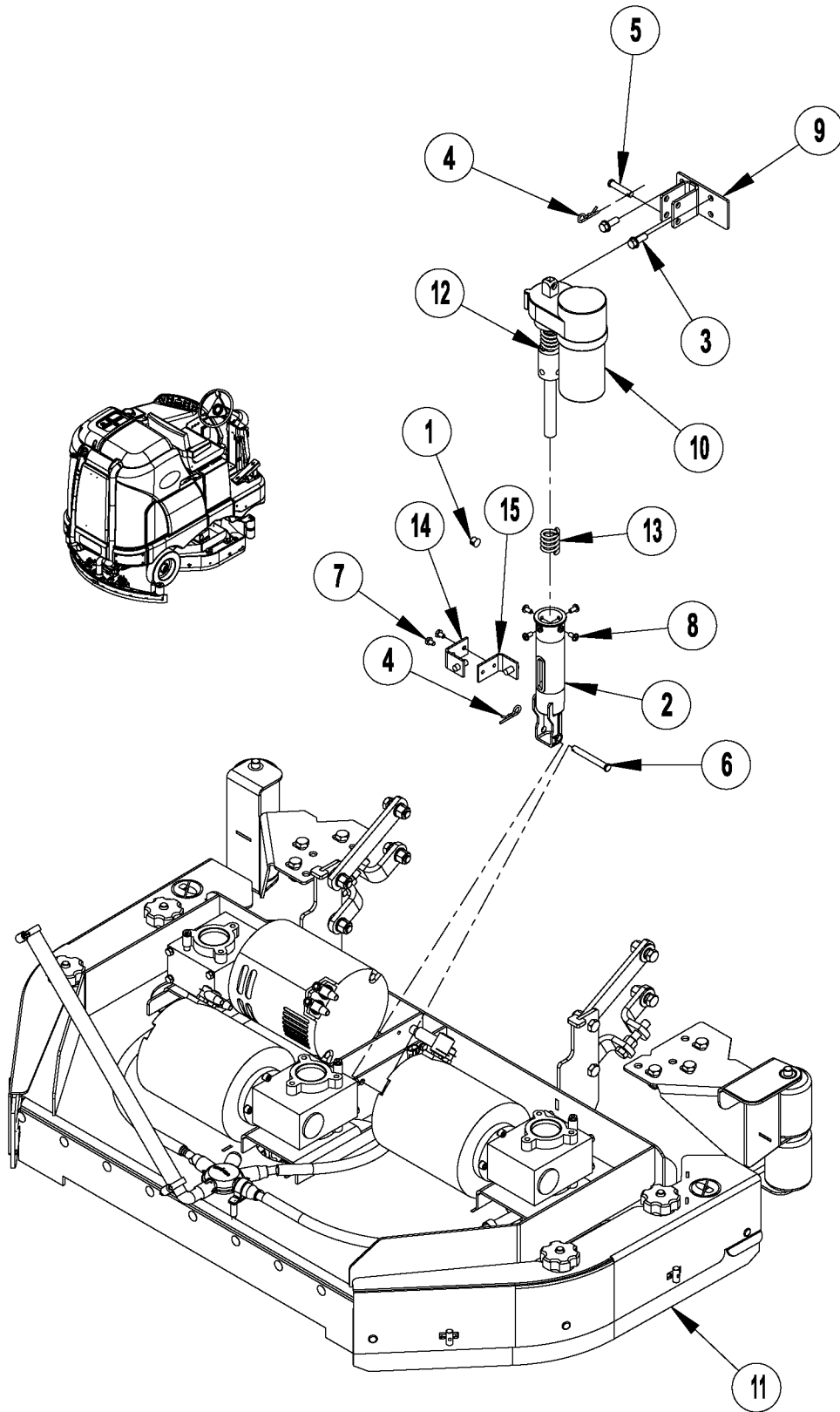

05-11

SCRUB SYSTEM-DISK

08-5

Condor™**23**

Item	Ref. No.	Qty	Description
1	56323560	1	Plug, Cap
2	56412262	1	Housing, Spring
3	56002256	2	Scr, Hex Type 1 3/8-16 X 1.00
4	56003222	2	Pin, Cotter Hair
5	56003597	1	Pin, Clevis .375 X 1.75
6	56003704	1	Pin, Clevis .38 X 3.00
7	56009019	2	Scr, Hex Thd Form 1/4-20 X .38
8	56009062	4	Scr, Pan Phil Thd Form 1/4-20 X .50
9	56413455	1	Mount Weldment
10	56413700	1	Actuator (M2)
11	56413794	1	40" Disk Scrub Assembly
	56413789	1	45" Disk Scrub Assembly
	56413791	1	48" Disk Scrub Assembly
12	56413828	1	Spring, Upper Housing
13	56413829	1	Spring, Lower Housing
14	56420019	1	Nut Retainer
15	56420020	1	Nut Retainer

Item	Ref. No.	Qty	Description	Item	Ref. No.	Qty	Description
	56413794	1	40" Disk Scrub Assembly	31	56314030	2	Brush Holder
1	56264262	1	Hose	32	56314108	2	Hub, Drive
2	56366455	2	Plate, Stop	33	56314109	2	Spacer
3	56366463	2	Spring Retainer	34	56315625	2	Barb, Coupler 1/2 X 3/4
4	56367206	8	Bushing	35	56410223	1	Clamp, P
5	56407053	4	Thermoid Disk	36	56413302	2	Arm Parallel 6 In
6	56407114	4	Knob	37	56413303	2	Arm, Adjustable Asm
7	56407334	4	Knob	38	56413318	1	Blade, Front
8	56409538	1	Insulator, Terminal	39	56413319	1	Blade, Rear
9	56471220	1	Bushing	40	56413334	1	Weldment, 40 Disk Deck
10	56002938	12	Wsh, Flt Sae Ss 5/16	41	56413336	1	Gearbox Assembly, 20" (M9)
11	56003263	16	Rivet, Nylon Tree Push-In (.25)	*	56410182	1	Bearing B.E. (for 56413336)
12	56003312	14	Nut, Hex Nyl Loc M12-1.75	*	56410183	1	Bearing F.E. (for 56413336)
13	56002885	6	Scr, Hex SS 3/8-16 X .75	*	56412266	1	Brush Board Assy (for 56413336)
14	56003372	2	Scr, Hex Loc Ss 5/16-18 X 1.25	*	56407500	1	Brush Assy Kit (for 56413336)
15	56003405	6	Nut, Hex Nyl Loc Ss M8-1.25	*	56389395	1	Brush Spring Set (for 56413336)
16	56003418	3	Scr, Hex M12-1.75 X 30mm	42	56413390	1	Resistor Assy, 1k Ohm (R2)
17	56003477	6	Scr, Hex Loc Ss M8-1 X 25mm	43	56413426	1	Manifold, Solution
18	56003637	8	Scr, Hex M12-1.75 X 40mm	44	56413578	1	Right Guard Assy (#52-56)
19	56003639	6	Scr, Hex Ss M8-1.25 X 30mm	45	56413307	1	Right Skirt Assembly
20	56003657	4	Nut, Hex Jam Ss M12-1.75	46	56413313	1	Left Skirt Assembly
21	56003658	4	Scr, Hex Thd To Hd Ss M12-1.75 X 70mm	47	56442003	2	Clamp,P
22	56009017	8	Wsh, Flt Harden .516x.938 X.75	48	56459064	2	Hose, PVC Clear 21.00 In.
23	56009019	1	Scr, Hex Thd Form 1/4-20 X .38	49	56493357	1	Insulator, Terminal
24	56009022	8	Wsh, Flt .754 X 1.250 X .120	50	56505794	2	Brush Prolene 20
25	56009028	1	Scr, Hex Thd Form 1/4-20 X 1.50	51	56900272	1	Barb, 3/4 90 Deg. Elbow
26	56009030	8	Scr, Pan Phil Thd Form 10-24 X .38	52	56407006	2	Wheel, Roller
27	56009057	2	Wsh, Flt Harden .344x1.000x.120/.135	53	56009097	2	Nut, Push Cap 1/2
28	56009096	2	Wsh, Flt .193 X .875 X .060	54	56413590	1	Pin
29	56112771	2	Clamp, Hose Sae #10	55	56413721	1	Grip Surface
30	56304586	8	Bearing .750 X .625 X .500	56	56413837	1	Guard Weld't.
				57	56413831	1	Roll Bar Weld't.
				58	56003415	3	Scr, Hex M12-1.75 x 35mm

* = Not Shown

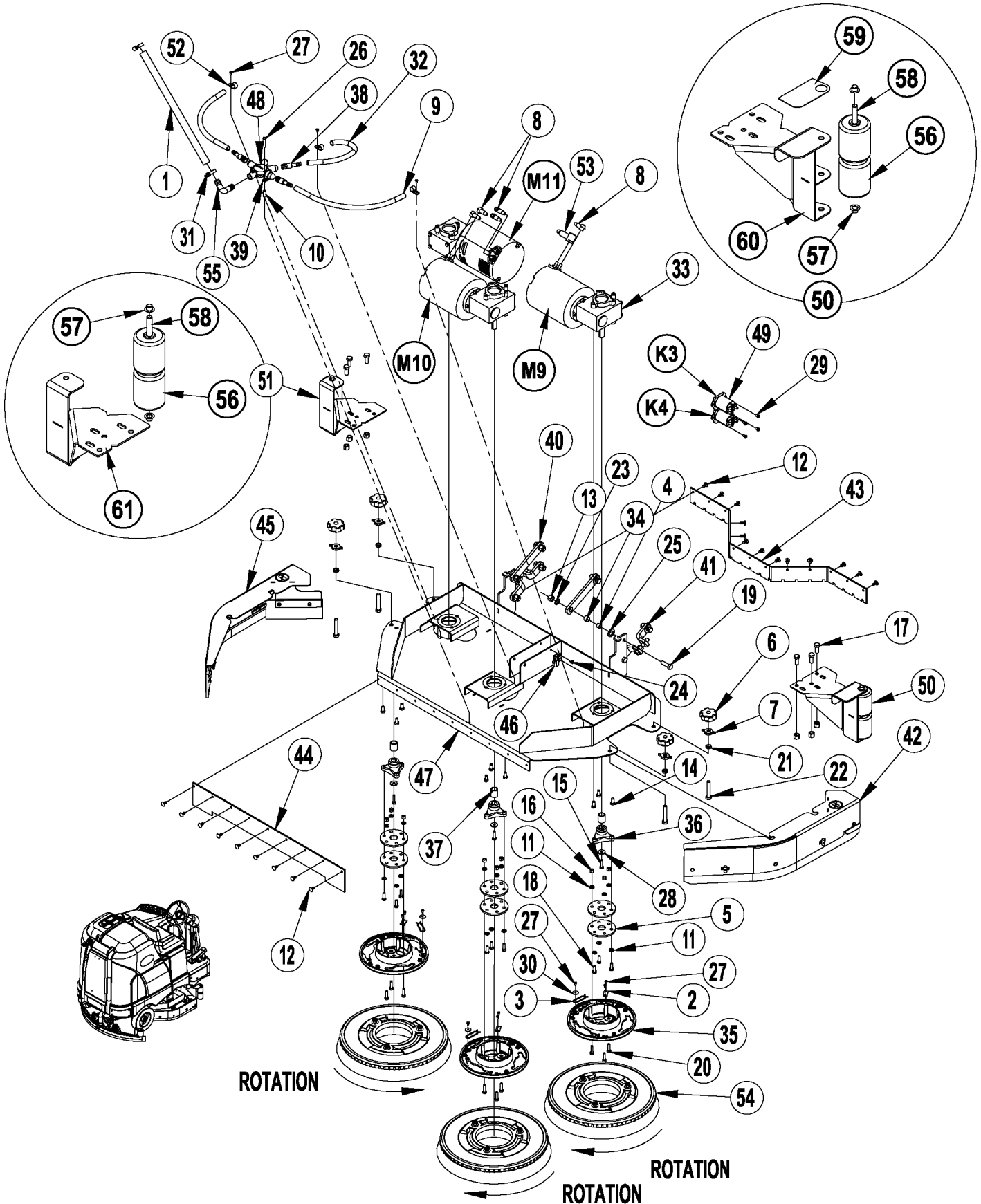

05-11

SCRUB SYSTEM-DISK (45", 48" scrub assembly)

08-11

Condor™**27**

Item	Ref. No.	Qty	Description	Item	Ref. No.	Qty	Description
1	56264262	1	Hose	31	56112771	2	Clamp, Hose SAE #10
2	56366455	3	Plate, Stop	32	56244986	1	Hose, Spiral .75 13.00 In.
3	56366463	3	Spring Retainer	33	56303083	3	Gearmotor (M9, M10, M11)
4	56367206	8	Bushing	#			DELETED
5	56407053	6	Thermoid Disk	*	56303444	4	Carbon Brush Assy (for 56303083)
6	56407114	4	Knob	*	56303419	4	Brush Spring (for 56303083)
7	56407334	4	Knob	34	56304586	8	Bearing .750 X .625 X .500
8	56409538	5	Insulator, Terminal	35	56314030	3	Brush Holder
9	56459064	2	Hose, PVC Clear 21.00 In	36	56314108	3	Hub, Drive
10	56471220	1	Bushing	37	56314109	3	Spacer
11	56002938	18	Wsh, Flt SAE SS 5/16	38	56315625	3	Barb, Coupler 1/2 X 3/4
12	56003263	22	Rivet, Nylon Tree Push-In (.25)	39	56410223	1	Clamp, P
13	56003312	14	Nut, Hex Nyl Loc M12-1.75	40	56413302	2	Arm Parallel 6 In
14	56002885	9	Scr, Hex SS 3/8-16 X .75	41	56413303	2	Arm, Adjustable Assy
15	56003372	3	Scr, Hex Loc SS 5/16-18 X 1.25	42	56413307	1	Right Skirt Assembly
16	56003405	9	Nut, Hex Nyl Loc SS M8-1.25	43	56413374	1	Blade Front
17	56003418	6	Scr, Hex M12-1.75 X 30mm	44	56413379	1	Blade, Rear
18	56003477	9	Scr, Hex Loc SS M8-1 X 25mm	45	56413381	1	Left Skirt Assembly
19	56003637	8	Scr, Hex M12-1.75 X 40mm	46	56413392	1	Resistor Assy, 20k Ohm (R2)
20	56003639	9	Scr, Hex SS M8-1.25 X 30mm	47	56413397	1	Deck Weldment 45
21	56003657	4	Nut, Hex Jam SS M12-1.75		56413396	1	Deck Weldment 48
22	56003658	4	Scr, Hex Thd To Hd SS M12-1.75 X 70mm	48	56413426	1	Manifold, Solution
23	56009017	8	Wsh, Flt Harden .516x.938 X.75	49	56413516	2	Contact, 36vdc 200a (K3, K4)
24	56009019	1	Scr, Hex Thd Form 1/4-20 X .38	50	56413578	1	Right Guard Assy (#56-60)
25	56009022	8	Wsh, Flt .754 X 1.250 X .120	51	56413584	1	Left Guard Assy (#56-58 & 61)
26	56009028	1	Scr, Hex Thd Form 1/4-20 X 1.50	52	56442003	3	Clamp,P
27	56009030	12	Scr, Pan Phil Thd Form 10-24 X .38	53	56493357	1	Insulator, Terminal
28	56009057	3	Wsh, Flt Harden .344x1.000x.120/.135	54	56505834	3	Brush, Prolene 16 (45")
29	56009062	4	Scr, Pan Phil Thd Form 1/4-20 X .50		56505784	3	Brush Prolene 17 (48")
30	56009096	3	Wsh, Flt .193 X .875 X .060	55	56900272	1	Barb, 3/4 90 Deg. Elbow
				56	56407006	2	Wheel, Roller (qty per assy)
				57	56009097	2	Nut, Push Cap 1/2 (qty per assy)
				58	56413590	1	Pin (qty per assy)
				59	56413721	1	Grip Surface
				60	56413837	1	Guard Weld't.
				61	56413571	1	Guard Weld't.

* = Not Shown

= Revised or new since last update

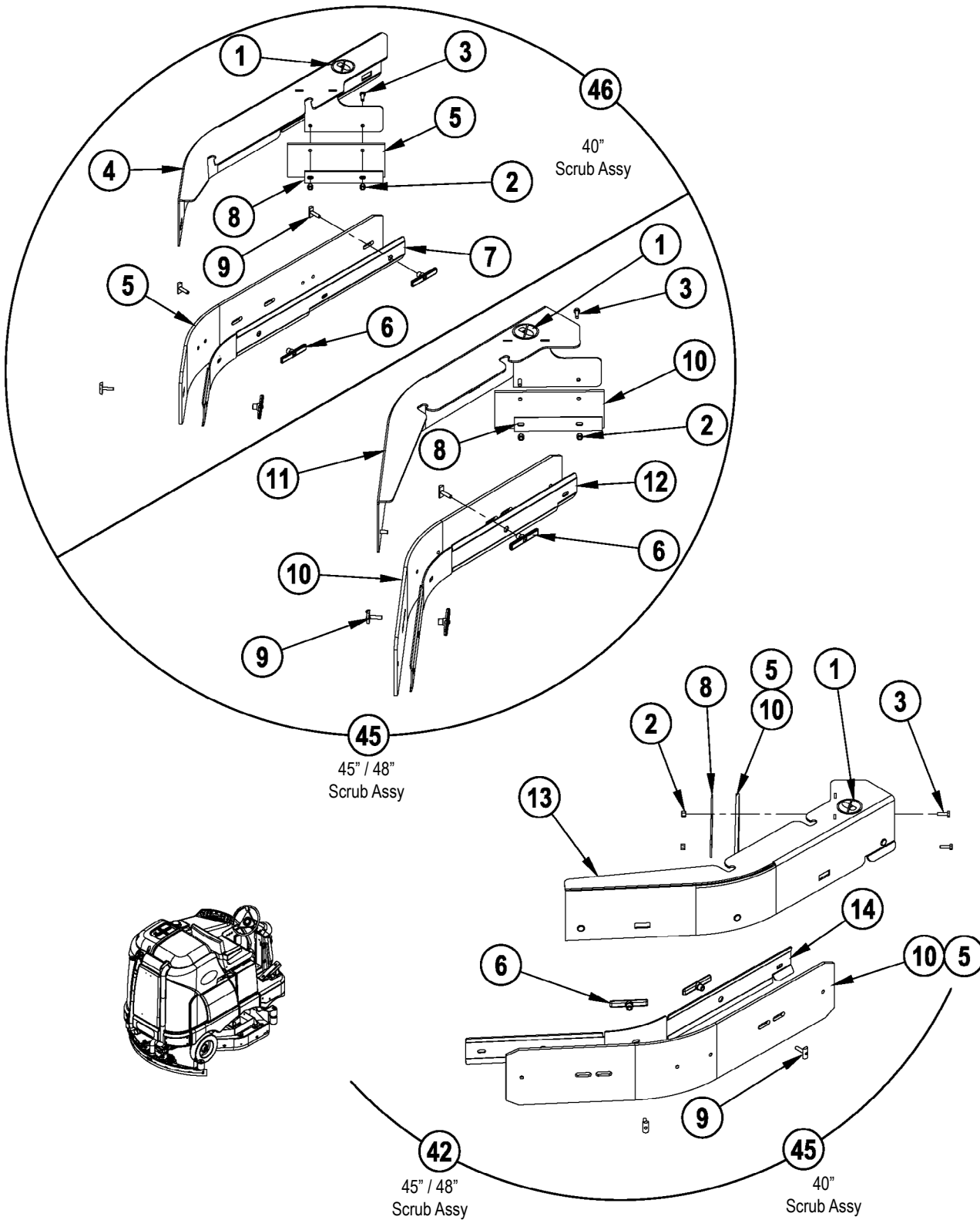

Item	Ref. No.	Qty	Description
45	56413307	1	Right Skirt Assembly (40") Page 24
46	56413313	1	Left Skirt Assembly (40") Page 24
42	56413307	1	Right Skirt Assembly (45" & 48") Page 26
45	56413381	1	Left Skirt Assembly (45" & 48") Page 26
1	56016163	1	Decal, No Step (qty per skirt assy)
2	56003426	2	Nut, Hex Nyl loc SS M6-1.00 (qty per skirt assy)
3	56003454	2	Scr, Hex Thd to Hd SS M6-1.00 x 20mm (qty per skirt assy)
4	56413314	1	Skirt Weld't. Left (40")
5	56413768	1	Kit, Linatex 40 Disk Blade NOTE 1
6	56413717	3	Thumb Nut (40" / qty per skirt assy)
	56413717	2	Thumb Nut (45" & 48" / qty per skirt assy)
7	56413718	1	Strap, Left (40")
8	56413725	1	Strap (qty per skirt assy)
9	56413850	3	Skirt Retainer Assy (40" / qty per skirt assy)
	56413850	2	Skirt Retainer Assy (45" & 48" / qty per skirt assy)
10	56413769	1	Kit, Gum Rubber (45" & 48") Disk Blade NOTE 1
	56413770	1	Kit, Linatex (45" & 48") Disk Blade NOTE 1
11	56413389	1	Skirt Weld't. Left (45" & 48")
12	56413712	1	Strap, Left (45" & 48")
13	56413308	1	Skirt Weld't. Right (40", 45" & 48")
14	56413690	1	Strap, Right (40", 45" & 48")

NOTE 1: All scrub deck blade kits include enough blades to replace all blades on both skirt assemblies.

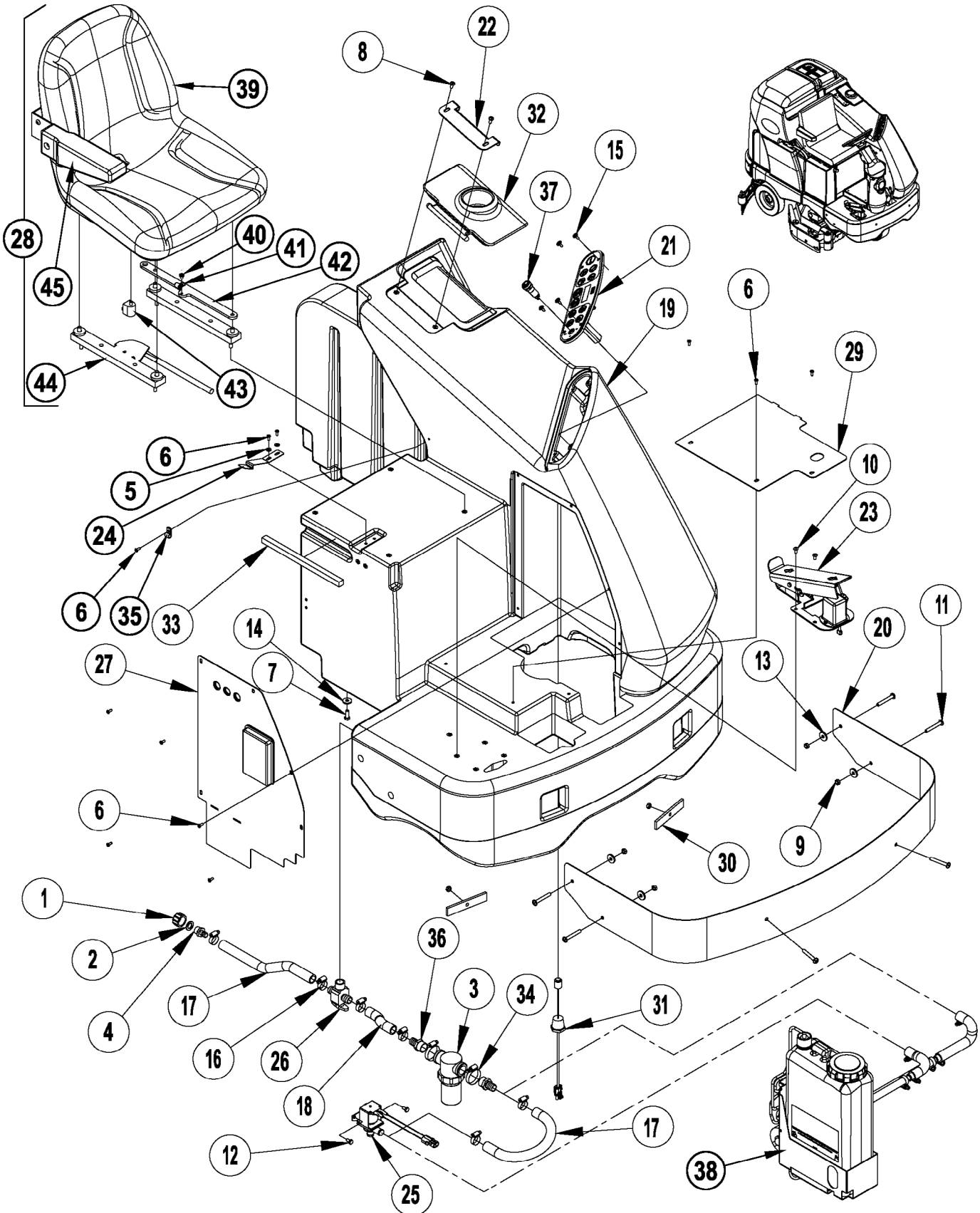

Item	Ref. No.	Qty	Description
1	56255076	1	Cap, Pipe Ght Nylon
2	56368776	1	Washer, Rubber
3	56407162	1	Filter
4	56900273	1	Barb
5	56001954	2	Wsh, Flt SAE #10
6	56001993	11	Scr, Pan Phil 10-24 X .50
7	56002037	4	Scr, Hex 5/16-18 X .88
8	56002066	2	Scr, Pan Phil 1/4-20 X .62
9	56002826	6	Nut, Hex Nyl Loc-Thin 5/16-18
10	56003119	5	Scr, Pan Phil SS 1/4-20 X .50
11	56003718	6	Scr, Pan Phil 5/16-18 X 2.25
12	56009033	2	Scr, Hex Thd Form 1/4-20 X .50
13	56009057	4	Wsh, Flt Harden .344x1.000x.120/.135
14	56009294	4	Wsh, Flt .354 X 1.247 X .125
15	56009206	4	Scr, Truss Phil-Blk 10-24x.50
16	56112771	6	Clamp, Hose SAE #10 (qty of 4 on AXP™ models)
17	56392193	2	Hose, .75 X 14.00
18	56413876	1	Hose .75 X 5.50
19	56413081	1	Tank, Solution
20	56413082	1	Bumper, Front
21	56413157	1	Touch Pad Assy (A3)
22	56413249	1	Mount, Lid
23#	56413421	1	Pedal Assy TSBUS2008-1001
24	56413482	1	Clip
25	56413510	1	Solenoid Valve Assy
26	56413581	1	Valve, T Shutoff
27	56413594	1	Panel, Elect. Cover Asm
28	56413619	1	Seat Mounting Assembly (39-45) NOTE 1
*	56003032	1	Scr, Hex Hd loc 1/2-13 x .75 NOTE 2
*	56003119	4	Scr, Pan Phil SS 1/4-20 x .50 NOTE 2
*	56409021	1	Seat Assy NOTE 1
*	56409613	1	Switch, Seat (S2) NOTE 2
*	56409536	1	Strap NOTE 2
*	56323260	1	Clamp, Hose Support NOTE 2
*	56002507	1	Scr, Pan Phil 1/4-20 x .75 NOTE 2
29	56413624	1	Floor Plate
30	56413653	2	Mount Plate, Bumper
31	56413669	1	Switch, Liquid Level (S5)
32	56413683	1	Solution Lid Assembly
33	56413811	1	Gasket, .62 X .62 X 11.50"
34	56413839	2	Clamp, Hose SAE #20
35	56342319	1	Clamp, P
36	56900292	2	Barb, Adapter 3/4 X 3/4npt
37	1450372000	1	Key Switch (S1)
*#	1462887000	A/R	Key, Replacement
38	56413862	1	Chemical Metering Assy (AXP™ models only)
39	7-69-00008	1	Seat
40	56003603	1	Scr, Pan Phil Thd Form 1/4-20 x .38
41	56323260	1	Clamp, Hose Support
42	56109274	1	Strap
43	7-82-00050	1	Switch
44	56109300	1	Slide, Seat
45	7-03-04250	1	Arm Rest Option

* = Not Shown

= Revised or new since last update

NOTE 1: Starting in August 2007 Seat Assy 56409021 will no longer be available. If you order part number 56409021 you will automatically receive Seat Assy Kit 56109291. When replacing 56409021 with 56109291 you will also need to order items (40, 41 & 42) above. Machines built after August 2007 will have the new seat assembly as pictured on the left.

NOTE 2: These items are replacement parts for machines built prior to August 2007. If your seat assembly looks like the one pictured on the left these parts are not used on your machine.

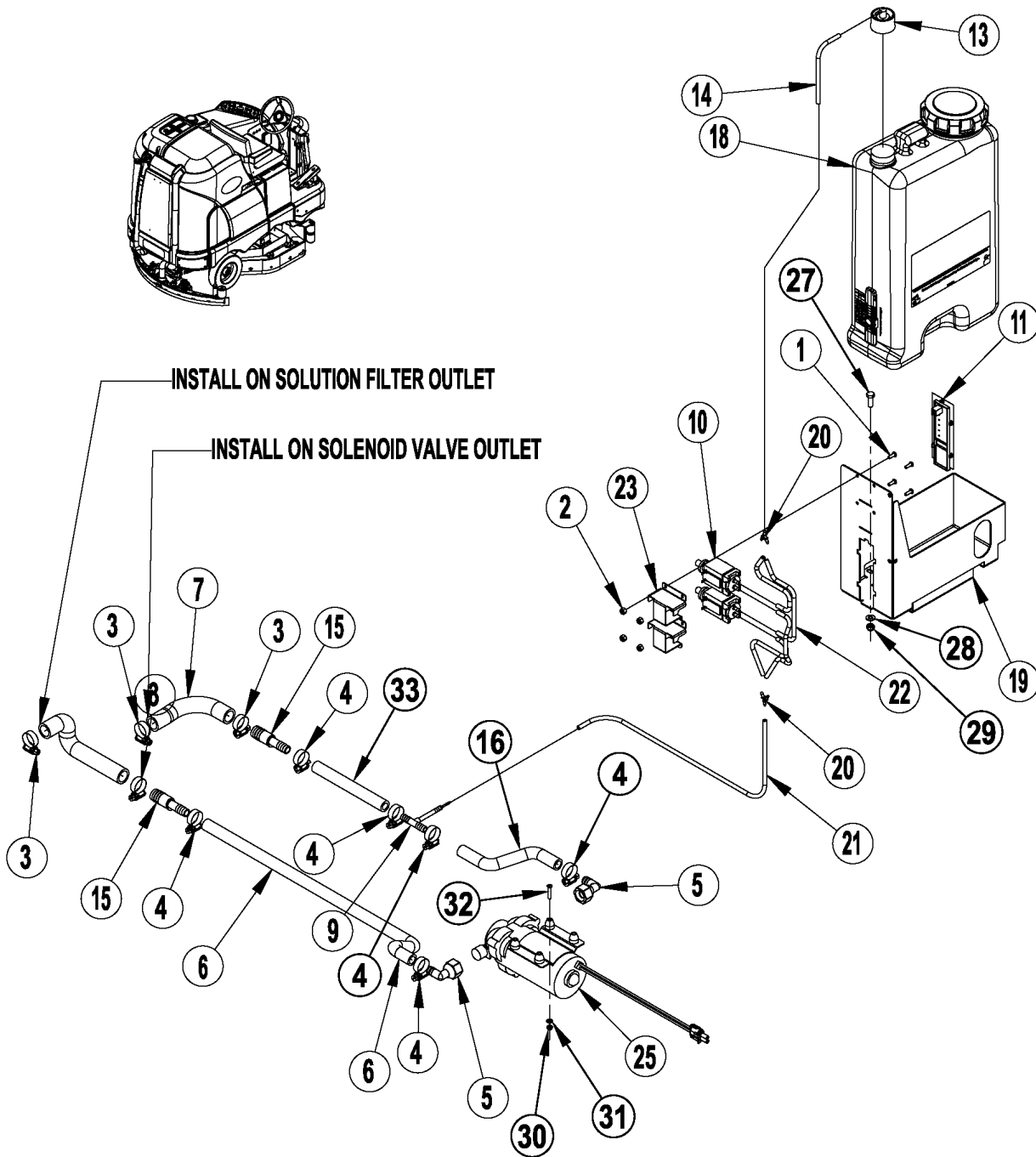

05-11

SOLUTION SYSTEM (chemical metering kit)

08-11

Condor™**33**

Item	Ref. No.	Qty	Description
	56413862	1	Chemical Metering Assy (AXP™ models only)
1	56002003	4	Scr, Pan Phil 8-32 X .50
2	56002808	4	Nut, Hex Nyl Loc 8-32
3	56112771	4	Clamp, Hose SAE #10
4	56219932	6	Clamp, Hose SAE #6
5	56261246	2	Elbow
6	56412275	1	Hose, Spiral .50
7	56305762	1	Hose, Spiral .750
9	56314983	1	Tee Assembly
10	56314984	2	Pump, Detergent (M13 / M16)
11	56315340	1	Chemical Sensor Assy (A4)
12			Intentionally Omitted
13	56315523	1	Cap, Dry Break, 1/8 Barb, 90
14	56315524	1	Hose, Chemical Resistant, 7.00
15	56315625	2	Barb, Coupler 1/2 X 3/4
16#	56262180	1	Hose, Spiral .50
18	56413999	1	Bottle, Chemical Assy
19	56413330	1	Plate, Mount, Chemical Meter
20	56413691	2	Fitting, Y, Barb
21	56413692	1	Hose, Chemical Resistant, 21.00
22	56413693	4	Hose, Chemical Resistant, 5.00
23	56413775	2	Bracket, Pump Mount
24			Intentionally Omitted
25#	56413810	1	Pump, 36V (M12) TSBUS2008-988
26	56481452	1	Hose, Spiral .750
27	56002507	3	Scr, Pan Phil 1/4-20 x .75
28	56002098	3	Wsh, Flt SAE 1/4
29	56002708	3	Nut, Nyl Loc 1/4-20
30	56002768	4	Nut, Nyl Loc 10-24
31	56001954	4	Wsh, Flt SAE #10
32	56002136	4	Scr, Flat Phil 10-24 x 1.25
33#	56412276	1	Hose, Spiral .50
*	56477613	2	Tie, Cable

* = Not Shown

= Revised or new since last update

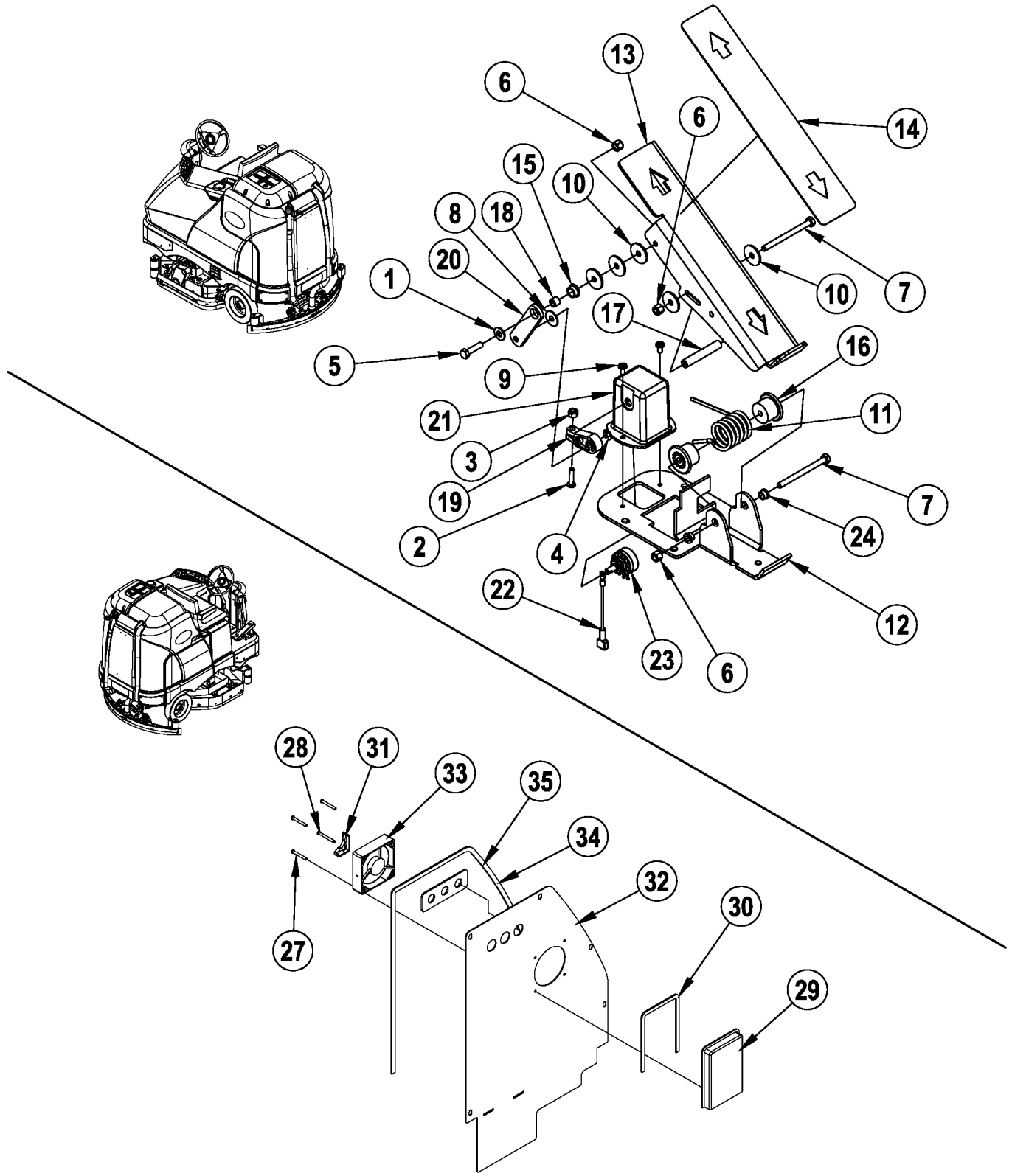

05-11

SOLUTION SYSTEM (drive pedal / electrical panel assy's)

08-11

Condor™

35

Item	Ref. No.	Qty	Description
#	56413421	1	Pedal Assy (#1-24) TSBUS2008-1001
	56413594	1	Panel, Elect. Cover Assy (#25-33)
1	56002098	1	Wsh, Flt Sae 1/4
2	56002733	1	Scr, Pan Phil 10-24 X .88
3	56002768	1	Nut, Hex Nyl Loc 10-24
4	56003268	1	Ring, Ret Ext Type E Reinf. 0.25 Dia
5	56003358	1	Scr, Hex M6-1 X 25mm
6	56003403	3	Nut, Hex Nyl Loc M6-1
7	56003428	2	Scr, Hex M6-1 X 75mm
8	56009025	1	Wsh, Flt .266 X .750 X .036
9	56009030	2	Scr, Pan Phil Thd Form 10-24 X .38
10	56009060	5	Wsh, Flt Ss .260 X 1.000 X .074
11	56314037	1	Spring, Torsion
12	NA	1	Bracket, Foot Pedal NOTE 1
13	NA	1	Foot Pedal NOTE 1
14	56314176	1	Mat, Pedal
15	56324505	1	Bearing, Flange
16	56380438	2	Spacer, Spring
17	56380439	1	Bushing
18	56380440	1	Bushing, M6 X .375 X .295
19	56409471	1	Lever, Throttle
20	56409610	1	Link Weldment
21	56412094	1	Housing, Potentiometer
22	56412331	1	Wire Assy.
23	56454740	1	Potentiometer, 5k (R1)
24	56756318	2	Bearing, Flange
25	56003531	1	Pin, Clevis .25 x 2.75
26	56001882	1	Pin, Cotter 1/16 x 3/4
27	56003199	3	Scr, Pan Phil Plastite 8-16 X 1.50
28	56003635	1	Scr, Pan Phil Plastite 8-16 X 1.75
29	56314590	1	Cover, Fan
30	56314594	1	Gasket
31	56314595	1	Board Holder
32	56413170	1	Cover, Electrical
33	56413597	1	Fan Assy (M14)
34	56413625	1	Gasket, Panel
35	56413626	1	Gasket, Circuit Breaker

= Revised or new since last update

NOTE 1: If you need to replace either of these items please order Pedal Assembly 56413421.

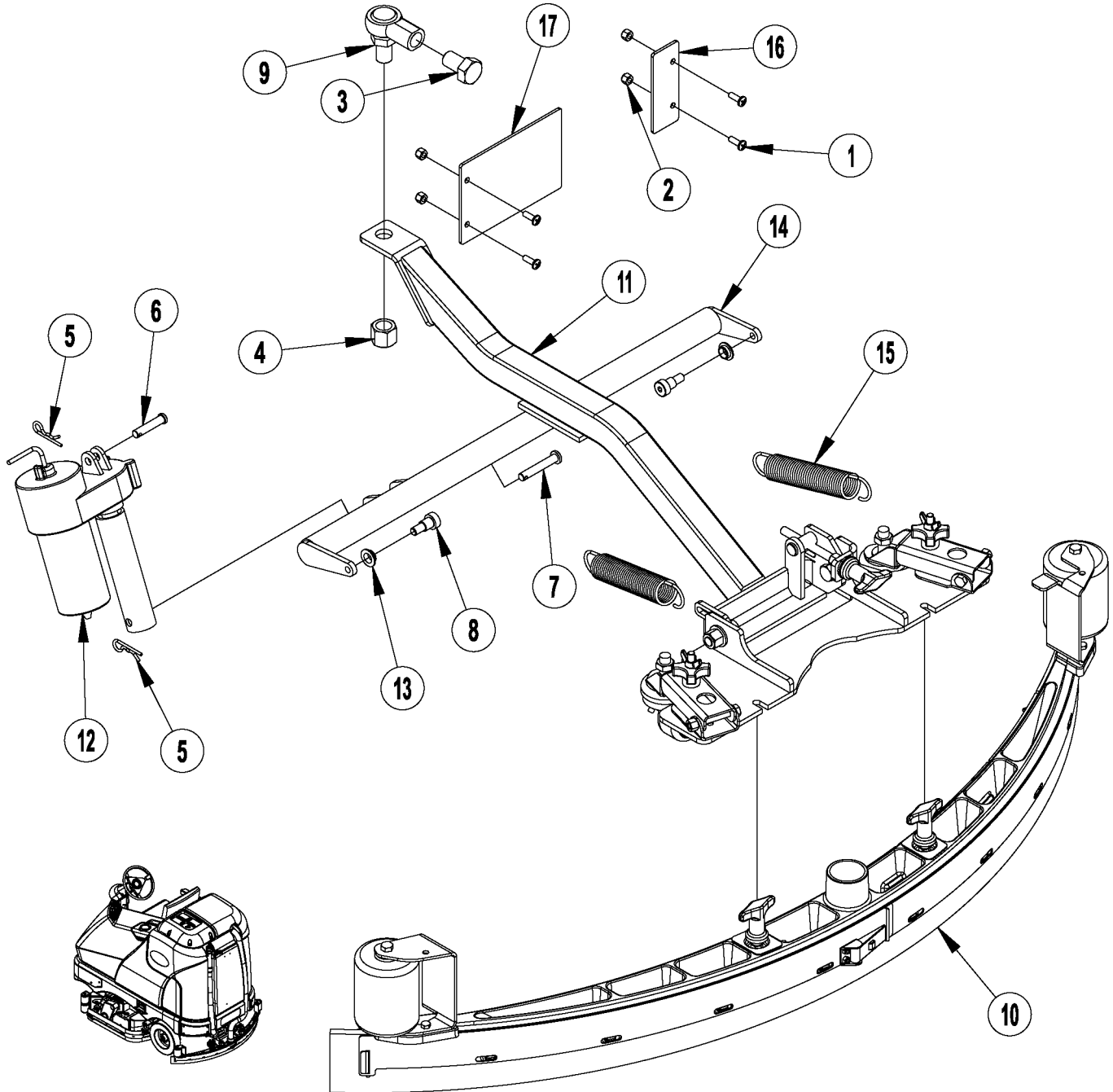

Item	Ref. No.	Qty	Description
1	56002507	4	Scr, Pan Phil 1/4-20 X .75
2	56002708	4	Nut, Hex Nyl Loc 1/4-20
3	56002739	1	Scr, Hex 3/4-16 X 1.25 Grade 8
4	56002863	1	Nut, Hex Nyl Loc 3/4-16
5	56003222	2	Pin, Cotter Hair
6	56003597	1	Pin, Clevis .375 X 1.75
7	56003656	1	Pin, Clevis .375 X 2.25
8	56003682	2	Scr, Soc Shd .50 X .50 X 3/8-16
9#	56380431	1	Ball Joint TSBUS2008-987
10	56413038	1	Squeegee Assembly F (40")
	56413478	1	Squeegee Assembly G (45")
	56413641	1	Squeegee Assembly H (48")
11	56413110	1	Squeegee Arm Assembly
12	56413111	1	Actuator 36v (M3)
13	56413211	2	Bearing, Flange .625 X .500 X .250
14	56413429	1	Squeegee Lift Arm Weldment
15	56412216	2	Spring, Extension
16	56413776	1	Stop Plate, Small (40")
17	56413778	1	Stop Plate, Large (40")
*	56413777	2	Stop Plate, Medium (45" & 48")

* = Not Shown

= Revised or new since last update

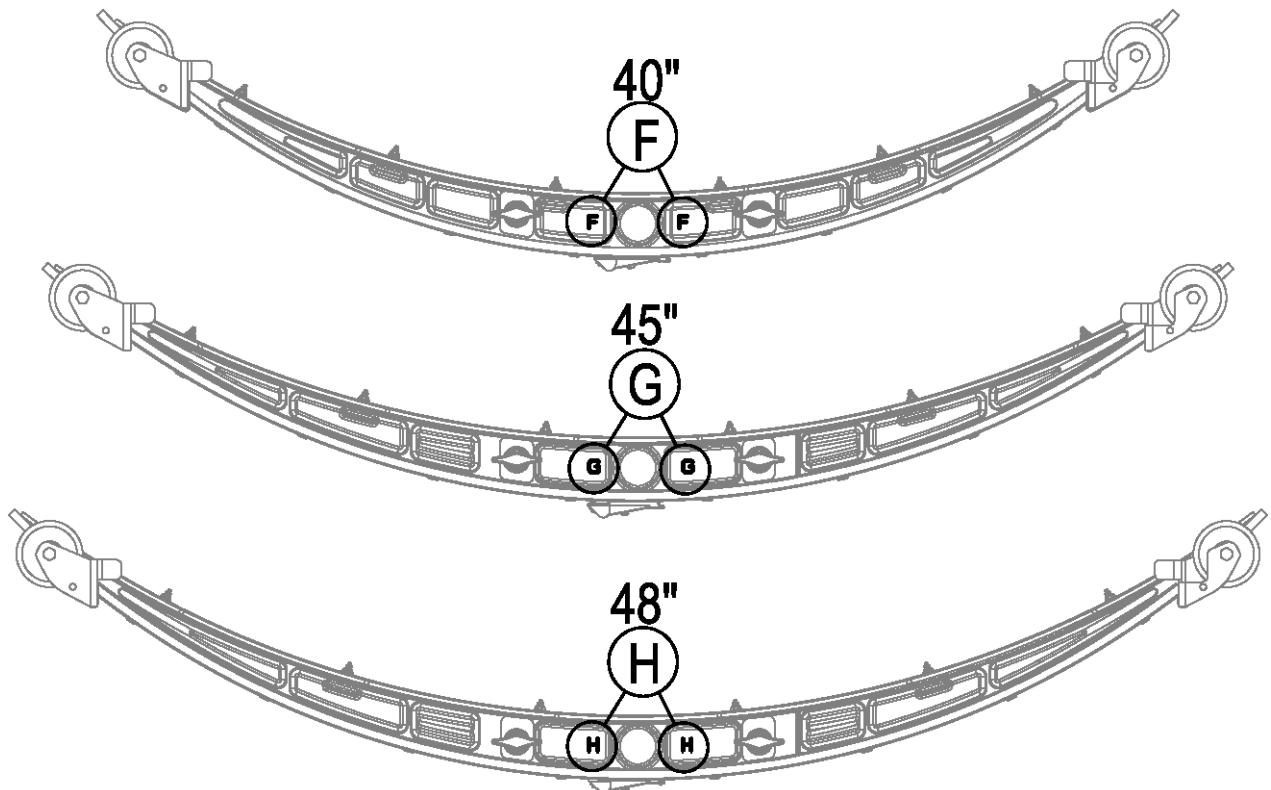

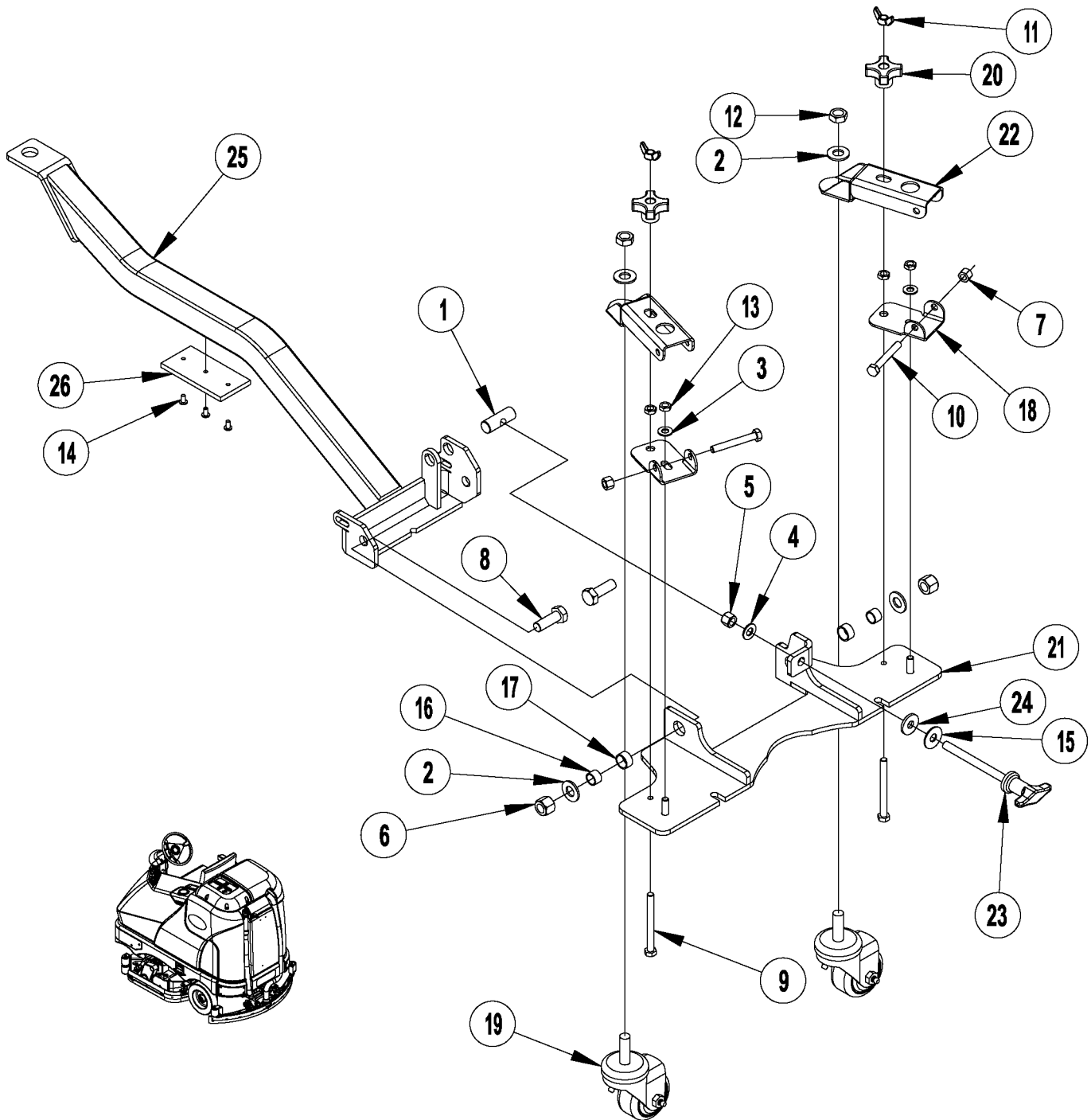

05-11

SQUEEGEE SYSTEM (squeegee arm assembly)

08-5

Condor™**39**

Item	Ref. No.	Qty	Description
	56413110	1	Squeegee Arm Assembly
1	56324369	1	Pin
2	56001879	4	Wsh, Flt SAE 1/2
3	56001939	2	Wsh, Flt SAE 5/16
4	56002063	1	Wsh, Flt SAE 3/8
5	56002769	1	Nut, Hex Nyl Loc 3/8-16
6	56003312	2	Nut, Hex Nyl Loc M12-1.75
7	56003405	2	Nut, Hex Nyl Loc Ss M8-1.25
8	56003415	2	Scr, Hex M12-1.75 X 35mm
9	56003463	2	Scr, Hex Thd To Hd SS 5/16-18 X 3.25
10	56003464	2	Scr, Hex SS M8-1.25 X 60mm
11	56003465	2	Nut, Wing SS 5/16-18
12	56009016	2	Nut, Hex Jam 1/2-13
13	56009086	4	Nut, Hex Jam 5/16-18
14	56009139	3	Scr, Pan Phil Loc 10-24 X .38
15	56151068	1	Washer, Fibre
16	56360627	2	Bushing
17	56370878	2	Bearing, Sleeve
18	56407302	2	Bracket
19	56407344	2	Caster Wheel
20	56407510	2	Knob, 5/16-18 Nyl Loc
21	56413264	1	Squeegee Mount Weldt TSBUS2007-969
22	56413517	2	Bracket
23	56413576	1	Knob
24	56413599	1	Washer, Rubber
25	56413640	1	Squeegee Arm Weldment
26	56413742	1	Pad, Wear, Squeegee Arm

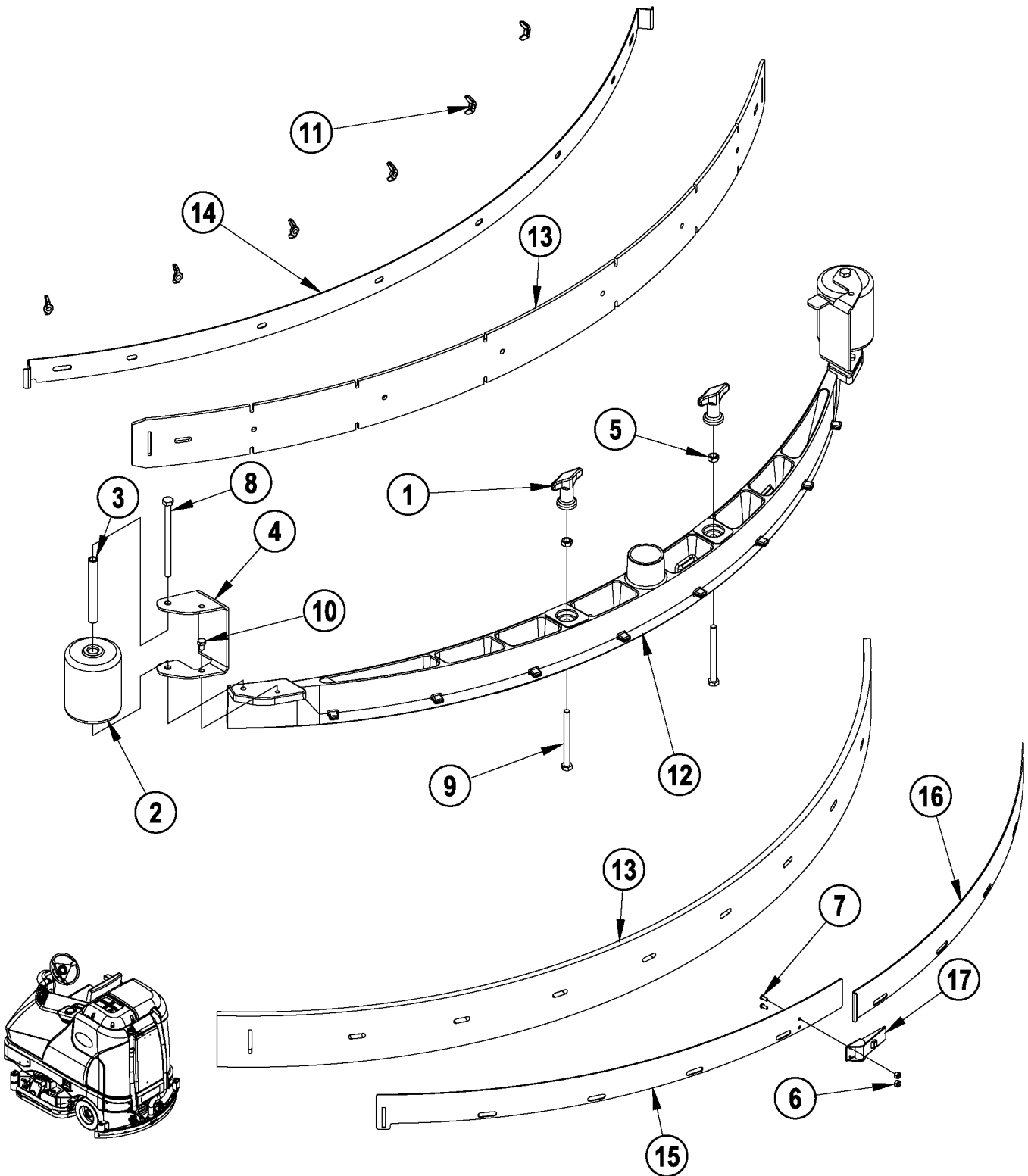

05-11

SQUEEGEE SYSTEM (squeegee assembly F / 40")

08-5

Condor™**41**

Item	Ref. No.	Qty	Description
	56413038	1	Squeegee Assembly F (40")
1	56370711	2	Nut, Thumb
2	56407006	2	Wheel, Roller
3	56407155	2	Bushing
4	56407375	2	Bracket
5	56002851	2	Nut, Hex Nyl Loc-Thin Ss 5/16-18
6	56002907	2	Nut, Hex Nyl Loc SS 6-32
7	56002909	2	Scr, Pan Phil SS 6-32 X .38
8	56003462	2	Scr, Hex SS M8-1.25 X 120mm
9	56003481	2	Scr, Hex Thd To Hd Ss 5/16-18 X 3.50
10	56003498	2	Scr, Hex SS M6-1 X 10mm
11	56009111	6	Nut, Wing SS 1/4-20
12	56413037	1	Squeegee, Cast F
13	56413762	1	Kit, Linatex Squeegee Blade F
**	56413761	1	Kit, Gum Rubber Squeegee Blade F
14	56413327	1	Strap, Front "F"
15	56413328	1	Strap, Rear F
16	56413329	1	Strap, Rear F
17	56471194	1	Latch Assembly

** = Optional, Not Included

NOTE: All squeegee blade kits include both front and rear squeegee blades.

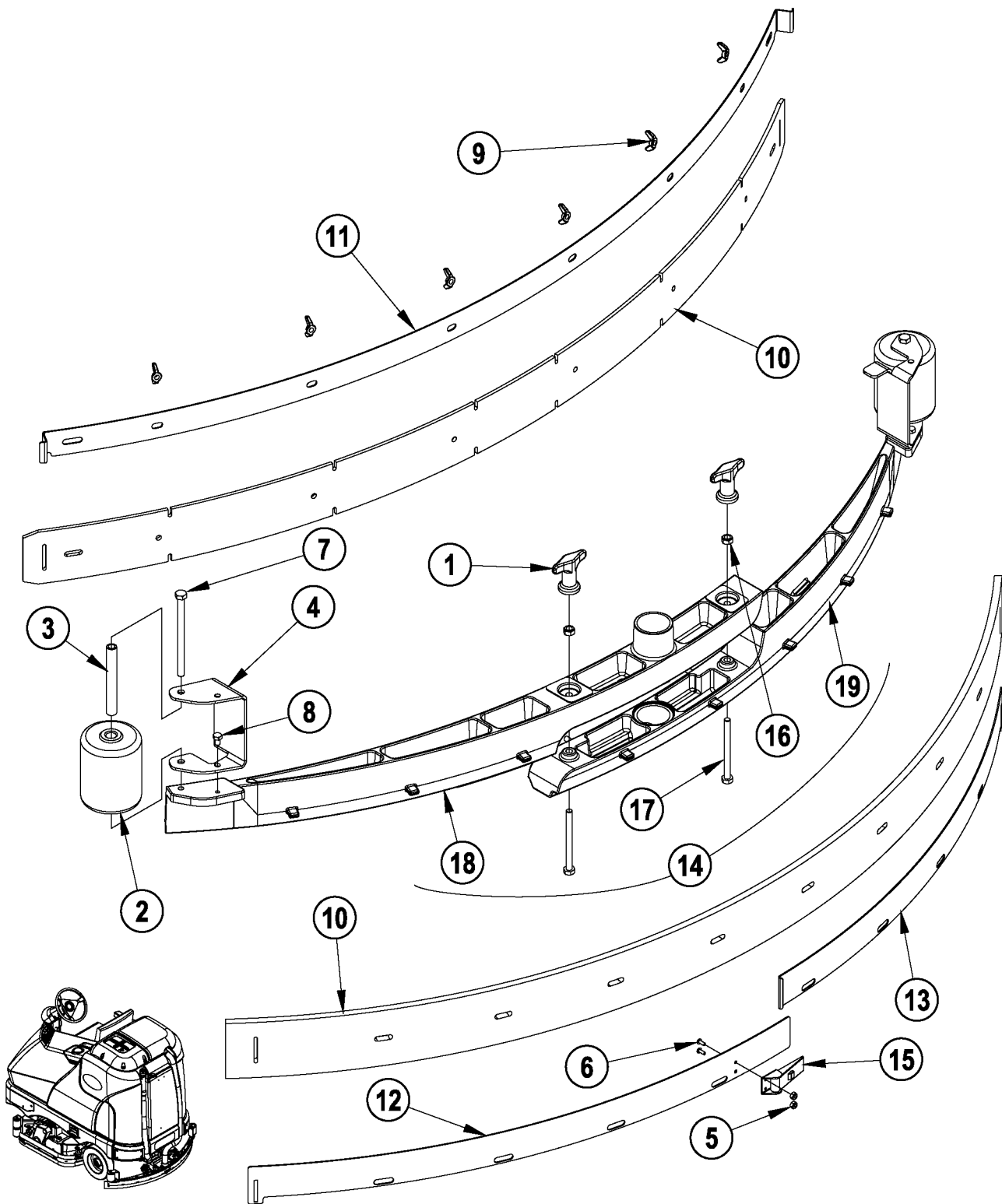

Item	Ref. No.	Qty	Description
	56413478	1	Squeegee Assembly G (45")
	56413641	1	Squeegee Assembly H (48")
1	56370711	2	Nut, Thumb
2	56407006	2	Wheel, Roller
3	56407155	2	Bushing
4	56407375	2	Bracket
5	56002907	2	Nut, Hex Nyl Loc SS 6-32
6	56002909	2	Scr, Pan Phil SS 6-32 X .38
7	56003462	2	Scr, Hex SS M8-1.25 X 120mm
8	56003498	2	Scr, Hex SS M6-1 X 10mm
9	56009111	6	Nut, Wing SS 1/4-20
10	56413756	1	Kit, Gum Rubber Squeegee Blade G (45")
	56413765	1	Kit, Gum Rubber Squeegee Blade H (48")
	56413757	1	Kit, Linatex Squeegee Blade G (45")
	56413766	1	Kit, Linatex Squeegee Blade H (48")
11	56413519	1	Strap, Front G (45")
	56413650	1	Strap, Front H (48")
12	56413520	1	Strap, Left Rear G (45")
	56413652	1	Strap, Left Rear H (48")
13	56413521	1	Strap, Right Rear G (45")
	56413651	1	Strap, Right Rear H (48")
14	56413680	1	Squeegee Cast Assy G (45") (#16-19)
	56413679	1	Squeegee Cast Assy H (48") (#16-19)
15	56471194	1	Latch Assembly
16	56002851	2	Nut, Hex Nyl Loc-Thin SS 5/16-18
17	56003481	2	Scr, Hex Thd to Hd SS 5/16-18 x 3.50
18	56413499	1	Squeegee, Cast G Top (45")
	56413645	1	Squeegee, Cast H Top (48")
19	56413515	1	Squeegee, Cast G Bottom (45")
	56413644	1	Squeegee, Cast H Bottom (48")

NOTE: All squeegee blade kits include both front and rear squeegee blades.

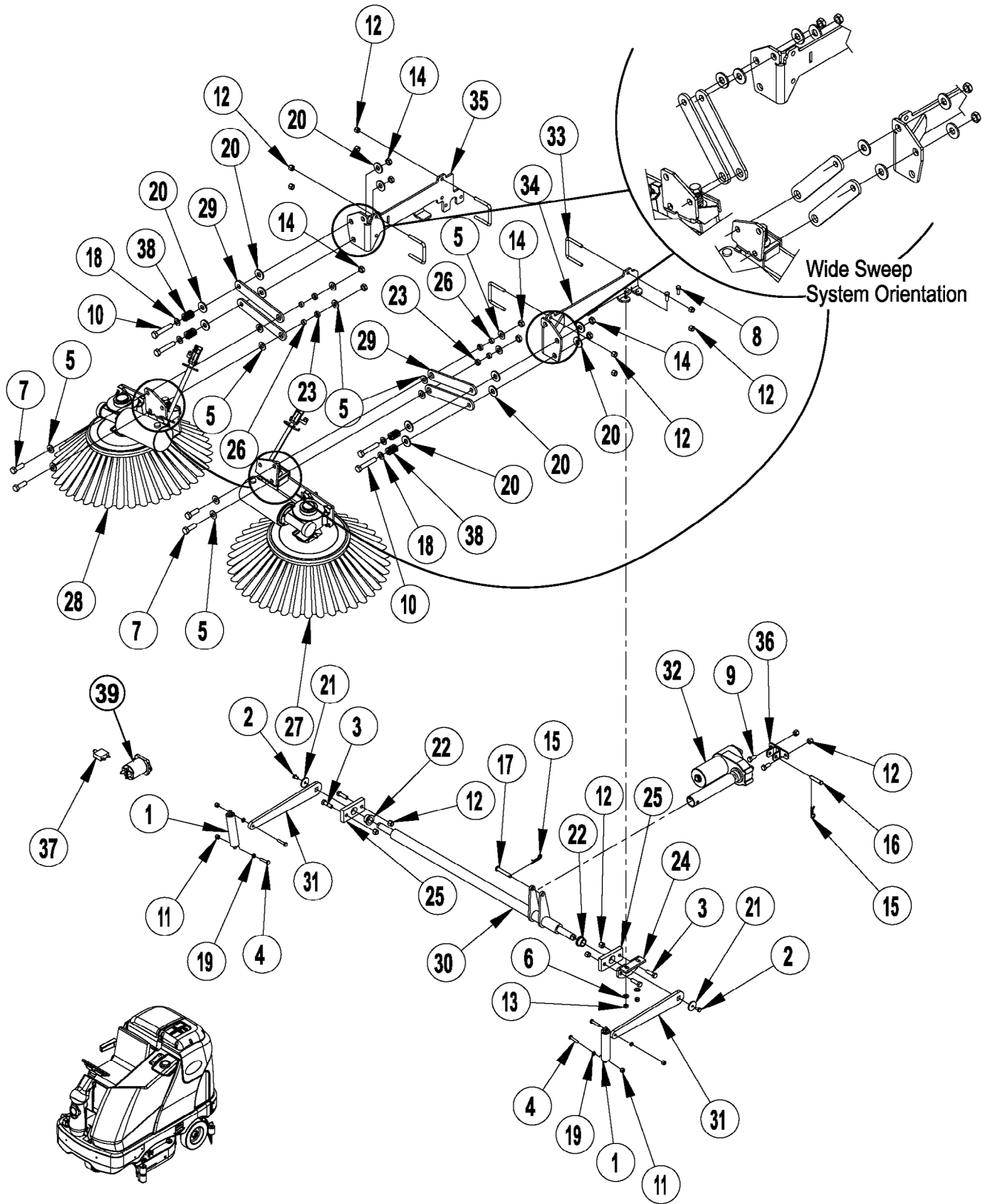

Item	Ref. No.	Qty	Description
1	56407335	2	Chain Assembly
2	56001854	2	Scr, Hex 1/4-20 X .50
3	56001858	4	Scr, Hex 3/8-16 X 1.25
4	56001878	4	Scr, Hex 1/4-20 X 1.25
5	56001879	12	Wsh, Flt SAE 1/2
6	56001939	2	Wsh, Flt SAE 5/16
7	56001968	4	Scr, Hex 1/2-13 X 1.50
8	56002037	2	Scr, Hex 5/16-18 X .88
9	56002271	2	Scr, Hex 3/8-16 X .88
10	56002680	4	Scr, Hex 1/2-13 X 2.75
11	56002708	4	Nut, Hex Nyl Loc 1/4-20
12	56002769	14	Nut, Hex Nyl Loc 3/8-16
13	56002826	2	Nut, Hex Nyl Loc-Thin 5/16-18
14	56002843	8	Nut, Hex Nyl Loc-Thin 1/2-13
15	56003222	2	Pin, Cotter Hair
16	56003597	1	Pin, Clevis .375 X 1.75
17	56003656	1	Pin, Clevis .375 X 2.25
18	56009017	4	Wsh, Flt Harden .516x.938 X.75
19	56009087	4	Nut, Hex Jam 1/4-20
20	56009115	12	Wsh, Flt Harden .594x1.375x.134
21	56009199	2	Wsh, Flt Brass .266x1.250x.125
22	56303071	2	Bearing, Flange
23	56304893	4	Bearing, Sleeve .625 X .750 X .250
24	56305080	1	Bracket, Side Broom Lift
25	56305091	2	Pillow Block
26	56365030	4	Bushing .50x.62x.27
27	56413039	1	Left Side Broom Assembly
28	56413040	1	Right Side Broom Assembly
29	56413048	4	Link
30	56413053	1	Sidebroom Lift Arm Weldment
31	56413055	2	Lift Arm
32	56413129	1	Actuator, Motor 36V (M4)
33	56413403	4	Clamp, Wide
34	56413453	1	Sidebroom Brkt Weld't, Lt
35	56413454	1	Sidebroom Brkt Weld't, Rt
36	56413479	1	Actuator Mount
37	56413822	1	Circuit Breaker, 20 Amp
38	56416508	4	Spring, Die
39#	56413516	1	Contactor, 36vdc 200a (K6) TSBUS2008-996

* = Not Shown

= Revised or new since last update

NOTE: As of October 2008 machines are no longer being manufactured with the "Narrow Sweep" system.

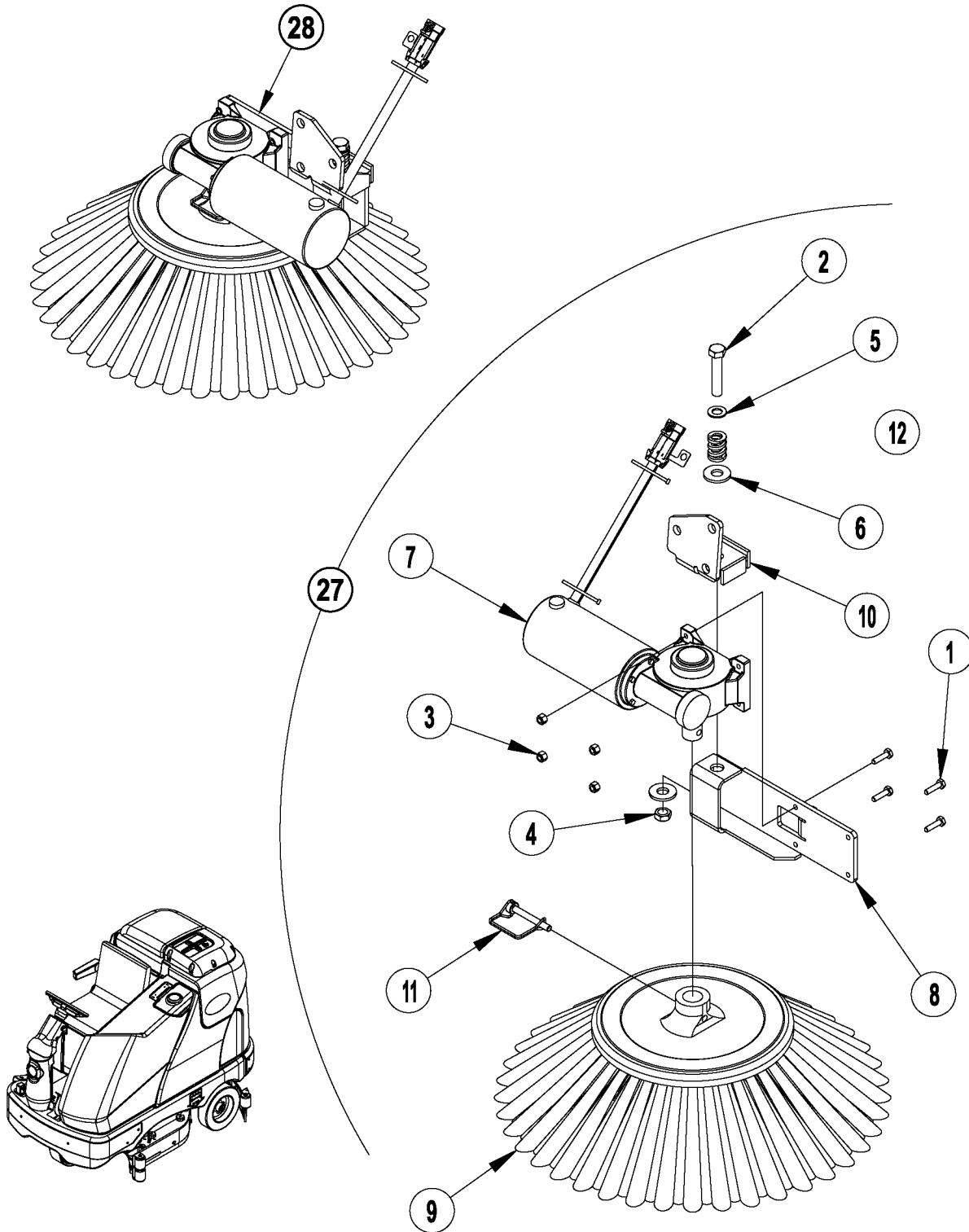

05-11

SWEEP SYSTEM (side broom assemblies)

08-5

Condor™**47**

Item	Ref. No.	Qty	Description
27	56413039	1	Left Side Broom Assembly Page 44
28	56413040	1	Right Side Broom Assembly Page 44
1	56002093	4	Scr, Hex 1/4-20 X 1.00
2	56002533	1	Scr, Hex 1/2-13 X 2.50
3	56002708	4	Nut, Hex Nyl Loc 1/4-20
4	56002843	1	Nut, Hex Nyl Loc-Thin 1/2-13
5	56009017	1	Wsh, Flt Harden .516x.938 X.75
6	56009115	2	Wsh, Flt Harden .594x1.375x.134
7	56413695	1	Gearmotor Assembly, 36VDC (Left-56413039 / M7)
*	56413696	1	Gearmotor Assembly, 36VDC (Right-56413040 / M8)
*	56413715	2	Carbon Brush for 56413695 / 56413696
8	56413051	1	Sidebroom Bracket Weld't, Lt (56413039)
*	56413062	1	Sidebroom Bracket Weld't, Rt (56413040)
9	56413056	1	Sidebroom
10	56413142	1	Sidebroom Spring Mt Weld't, Lt (56413039)
*	56413143	1	Sidebroom Spring Mt Weld't, Rt (56413040)
11	56413845	1	Pin, .31 With Retainer
12	56416508	1	Spring, Die

* = Not Shown

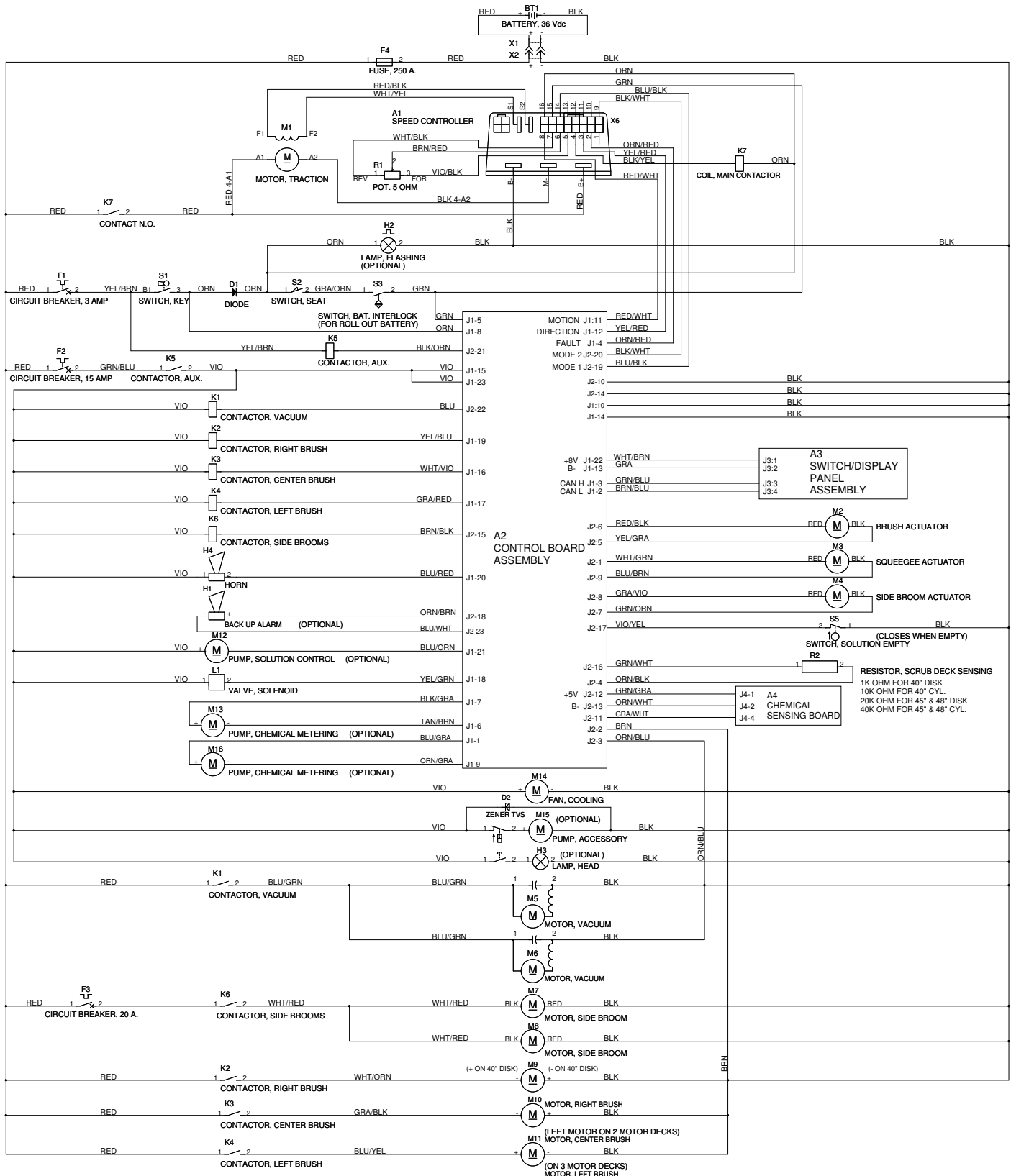

Item	Ref. No.	Qty	Description	Item	Ref. No.	Qty	Description
A1	56413041	1	Speed Control	M9	56413336	1	Gearbox Assy (40" disk)
A2	56413483	1	Control Board Assembly	*	56410182	1	Bearing B.E. (for 56413336)
A3	56413157	1	Switch/Display Panel Assembly	*	56410183	1	Bearing F.E. (for 56413336)
A4	56315340	1	Chemical Sensing Board (AXP)	*	56412266	1	Brush Board Assy (for 56413336)
				*	56407500	1	Brush Assy Kit (for 56413336)
BT1	N/A		Battery	*	56389395	1	Brush Spring Set (for 56413336)
				M9	56303083	1	Gearmotor (45" & 48" disk right motor)
D1	NA	1	Diode	*#			DELETED
D2	NA	1	Diode (part of M15)	*	56303444	4	Carbon Brush Assy (for 56303083)
				*	56303419	4	Brush Spring (for 56303083)
F1	56413406	1	Circuit Breaker, 3 Amp (Control Circuit)	M9	56413398	1	Motor, 36VDC 1.5HP (all cylindrical right motor)
F2	56413407	1	Circuit Breaker, 15 Amp (Auxiliary Circuit)	*	56413628	1	Brush & Spring Kit (for 56413398)
F3	56413822	1	Circuit Breaker, 20 Amp (Side Brooms)	M10	56303083	1	Gearmotor (45" & 48" disk center motor)
F4	56410044	1	Fuse, 250 Amp	*#			DELETED
				*	56303444	4	Carbon Brush Assy (for 56303083)
H1	56412177	1	Backup Alarm (optional)	*	56303419	4	Brush Spring (for 56303083)
H2	56305223	1	Strobe Light (optional)	M10	56413398	1	Motor, 36VDC 1.5HP (all cylindrical left motor)
H3	56409239	1	Headlight (optional)	*	56413628	1	Brush & Spring Kit (for 56413398)
H4	56482365	1	Horn	M11	56303083	1	Gearmotor (45" & 48" disk left motor)
				*#			DELETED
K1#	56413516	1	Contact, Vacuum TSBUS2008-996	*	56303444	4	Carbon Brush Assy (for 56303083)
K2	56413516	1	Contact, Right Brush (all models)	*	56303419	4	Brush Spring (for 56303083)
K3	56413516	1	Contact, Center Brush (45" & 48" disk and all cylindrical)	M12#	56413810	1	Pump, Solution Control (AXP) TSBUS2008-988
K4	56413516	1	Contact, Left Brush (45" & 48" disk only)	M13	56314984	1	Pump, Chemical Metering (AXP)
K5#	56413516	1	Contact, Auxiliary TSBUS2008-996	M14	56413597	1	Fan Assy
K6#	56413516	1	Contact, Side Brooms TSBUS2008-996	M15	56212014	1	Pump, Accessory (optional)
K7	56413516	1	Contact, Main	M16	56314984	1	Pump, Chemical Metering (AXP)
L1	56413510	1	Solenoid Valve	R1	56454740	1	Potentiometer, 5K Ohm
M1	56413615	1	Motor, Traction	R2	56413390	1	Resistor Assy, 1k Ohm (40" disk)
*	56413616	1	Carbon Brush Set		56413393	1	Resistor Assy, 10k Ohm (40" cylindrical)
*#			DELETED		56413392	1	Resistor Assy, 20k Ohm (45" & 48" disk)
*#			DELETED		56413391	1	Resistor Assy, 40k Ohm (45" & 48" cylindrical)
M2	56413700	1	Lift Actuator, Brush	S1	1450372000	1	Switch, Key
M3	56413111	1	Lift Actuator, Squeegee	*#	1462887000	1	Key, Replacement
M4	56413129	1	Lift Actuator, Side Broom	S2	56409613	1	Switch, Seat
M5	56410065	1	Motor Assy, Vac	S3	56305053	1	Switch, Batter Interlock (optional)
*	56212223	1	Carbon Brush Set	S5	56413669	1	Switch, Solution Empty
M6	56410065	1	Motor Assy, Vac (Optional)				
*	56212223	1	Carbon Brush Set				
M7	56413695	1	Gearmotor Assy, 36VDC (Left-cylindrical models only)				
*	56413715	2	Carbon Brush for 56413695				
M8	56413696	1	Gearmotor Assy, 36VDC (Right-cylindrical models only)				
*	56413715	2	Carbon Brush for 56413696				

* = Not Shown

= Revised or new since last update

BRUSH SELECTOR GUIDE-DISK

05-11

50

Condor™

07-1

We provide brushes and pad holders that will give you the best possible performance between machine and floor. Following are descriptions of the materials and their applications.

- Union Mix:** Medium grade natural fibers for polishing finished floors with standard-speed equipment. Recommended for use in place of white pads.
- ProLite:** Bristles are made from light-duty polypropylene for general scrubbing when you do not want to scratch or remove finish from the floor. Recommended for use in place of red pads.
- Prolene:** Polypropylene material for medium-duty scrubbing on concrete, terrazzo and vinyl floor tile. Recommended for use in place of green or blue pads.
- Magna Grit:** For extreme heavy-duty scrubbing or stripping of floors. This brush has extra large diameter silicon carbide grit impregnated synthetic bristles. Recommended for use in place of black pads.
- Dyna Grit:** For aggressive, heavy-duty scrubbing or stripping of floors. Recommended for use in place of brown pads.
- MidLite Grit:** For general purpose scrubbing of sealed or unsealed concrete, stone, terrazzo, quarry tile and other resilient hard floor surfaces. Recommended for use in place of green or blue pads.
- MidGrit:** For general purpose scrubbing when you need a lighter action for sealed or unsealed concrete, stone, terrazzo, quarry tile and other resilient hard floor surfaces. Recommended for use in place of green or blue pads.
- AgLite Grit:** For light scrubbing when used wet; buffing or polishing when used dry on urethane coated, sealed concrete or other resilient hard surface floors. Recommended for use in place of red or white pads.
- Short Trim Pad Holder:** Made with a structural foam block and center ring for correct pad centering. It has a "shower feed" design for getting solution to the floor.

40" BRUSHES

- 56505790 - Short Trim Pad Holder
- 56505195 - Pad Retainer for 56505790
- 56505791 - Magna Grit
- 56505792 - Dyna Grit
- 56505793 - AgLite Grit
- 56505794 - Prolene
- 56505795 - Prolite
- 56505796 - Union Mix
- 56505797 - MidGrit
- 56505798 - MidLite Grit

45" BRUSHES

- 56505830 - Short Trim Pad Holder
- 56505195 - Pad Retainer for 56505830
- 56505831 - Magna Grit
- 56505832 - Dyna Grit
- 56505833 - AgLite Grit
- 56505834 - Prolene
- 56505835 - Prolite
- 56505836 - Union Mix
- 56505837 - MidGrit
- 56505838 - MidLite Grit

48" BRUSHES

- 56505780 - Short Trim Pad Holder
- 56505195 - Pad Retainer for 56505780
- 56505781 - Magna Grit
- 56505782 - Dyna Grit
- 56505783 - AgLite Grit
- 56505784 - Prolene
- 56505785 - Prolite
- 56505786 - Union Mix
- 56505787 - MidGrit
- 56505788 - MidLite Grit

DISC BRUSH APPLICATION GUIDE (SUGGESTION ONLY)

Application	46 Grit	80 Grit	180 Grit	240 Grit	500 Grit	Prolene	Prolite	Union Mix
Stripping:								
Concrete	X	X						
Terrazzo	X	X						
Ceramic/Quarry tile		X						
Vinyl tile		X						
General Scrubbing:								
Concrete	X	X	X	X		X		
Terrazzo			X	X	X	X		
Ceramic/Quarry tile			X	X	X	X		
Marble					X		X	
Vinyl tile			X		X	X		
Raised-rubber tile					X		X	
Polishing:								
Raised Disc Tile								X
Marble								X
Vinyl tile								X

We provide brushes and pad holders that will give you the best possible performance between machine and floor. Following are descriptions of the materials and their applications.

- 80 Grit Brush:** Medium aggressive grit brush. Good all-around brush for medium to heavy buildup removal. Can also be used for general stripping operations.
- 180 Grit Brush:** Least aggressive grit brush. Used for daily cleaning of hard-finished floors.
- Polypropylene Brush:** Standard equipment brush. Low cost, yet effective in cleaning many common floor surfaces.
- Stiff Nylon Brush:** Cleaning action similar to polypropylene. More durable and wear-resistant than polypropylene.
- Soft Nylon Brush:** Least aggressive brush available. Used on soft-finish floors where a more aggressive brush would leave scratch marks, or in applications requiring very light cleaning.

40" BRUSHES

56413113 - Soft Nylon
 56413114 - Hard Nylon
 56413118 - Prolene
 56413115 - 180 Grit
 56413116 - 80 Grit

45" BRUSHES

56413434 - Soft Nylon
 56413435 - Hard Nylon
 56413439 - Prolene
 56413436 - 180 Grit
 56413437 - 80 Grit

48" BRUSHES

56413352 - Soft Nylon
 56413353 - Hard Nylon
 56413357 - Prolene
 56413354 - 180 Grit
 56413355 - 80 Grit

CYLINDRICAL BRUSH APPLICATION GUIDE (SUGGESTION ONLY)

Application	80 Grit	180 Grit	Polypro- pylene	Stiff Nylon	Soft Nylon
Stripping:					
Concrete	X				
Terrazzo	X				
Ceramic/Quarry tile	X				
Vinyl tile	X				
General Scrubbing:					
Concrete	X	X	X	X	
Terrazzo		X	X	X	X
Ceramic/Quarry tile		X	X	X	X
Marble		X		X	X
Vinyl tile		X	X	X	X
Raised-rubber tile		X			X

OPTIONAL KITS AND ACCESSORIES

05-11

52

Condor™

08-11

Item	Ref. No.	Qty	Description
Optional Kits			
**	56413740	1	Kit, Battery Tray Only
**	56413821	1	Vacuum Motor Kit, (2nd Vac Motor)
**	56413089	1	Kit, Heavy Front Bumper
**	56413764	1	Kit, Deluxe Seat
**	56413687	1	Kit, Spray Wand
**	56413649	1	Kit, Warning Beacon
**	56413681	1	Kit, Back-Up Alarm
**	56413774	1	Kit, Overhead Guard
**#			DELETED
**#	56109306	1	Kit, Seat Belt NOTE 2
**	56314313	1	Kit, Headlight
**	56413773	1	Kit, Operator Foot Guard
**	56413685	1	Kit, Solution Auto-Fill
**	56303386	1	Kit, Battery Bracket Disconnect
**	56413819	1	Kit, Floor Mat
**	56413803	1	40" Disk Scrub Kit
**	56413804	1	40" Cyl Scrub Kit
**	56413805	1	45" Disk Scrub Kit
**	56413806	1	45" Cyl Scrub Kit
**	56413807	1	48" Disk Scrub Kit
**	56413808	1	48" Cyl Scrub Kit

** = Optional, Not Included
 # = Revised or new since last update

NOTE 1: Replacement parts for the kits listed above can be found on each kit's associated instruction sheet.
NOTE 2: This seat belt kit is for use on Seat 7-69-00008.

Item	Ref. No.	Qty	Description
40" Squeegee Blade Kits			
**	56413761	1	Kit, Gum Rubber Squeegee Blade F NOTE 1
**	56413762	1	Kit, Linatex Squeegee Blade F NOTE 1
45" Squeegee Blade Kits			
**	56413756	1	Kit, Gum Rubber Squeegee Blade G NOTE 1
**	56413757	1	Kit, Linatex Squeegee Blade G NOTE 1
48" Squeegee Blade Kits			
**	56413765	1	Kit, Gum Rubber Squeegee Blade H NOTE 1
**	56413766	1	Kit, Linatex Squeegee Blade H NOTE 1
40" Disk Deck Blade Kits			
**	56413767	1	Kit, Gum Rubber 40 Disk Blade NOTE 2
**	56413768	1	Kit, Linatex 40 Disk Blade NOTE 2
45", 48" Disk Deck Blade Kits			
**	56413769	1	Kit, Gum Rubber 45/48 Disk Blade NOTE 2
**	56413770	1	Kit, Linatex 45/48 Disk Blade NOTE 2
Cylindrical Deck Blades			
**	56413820	2	Skirt, Gum Rubber
**	56413654	2	Skirt, Linatex (Std)
Optional Battery Kits			
**	56413799	1	Kit, Battery 36V Roll Out
**	56413666	1	Kit, Battery 36V
**	56413735	1	Kit, Battery 6V 395 A/H (20 Hr)
**	56380425	1	Kit, Battery Roll Out – No Batt
**#	56380485	1	Kit, Battery Roll Out – No Batt (use with 56380422)
**#	56380422	1	Battery 36V 450 AH (use with 56380485)
Optional Battery Chargers			
**	56388119	1	Charger, 36vdc, 36amp 230vac/50hz
**	56388120	1	Charger, 36vdc Auto 36amp 120vac/60hz
**	56409788	1	Charger, 36vdc 38amp 200-250vac/50-60hz
**	56380423	1	Charger, 36v SCR, 3 Phase
**	56380424	1	Charger, 36v SCR, 1 Phase
Accessories			
**	56409441	A/R	Programmer, 1311 User
**	56410508	A/R	Programmer Cable
**	56303429	1	Cart, Battery Exchange
**	56303430	1	Rack, Battery Storage

** = Optional, Not Included

= Revised or new since last update

NOTE 1: Squeegee Blade Kits include both front & rear squeegee blades.

NOTE 2: Disk Deck Blade Kits include all skirt assembly blades.



**Nilfisk
Advance**

setting standards

Nilfisk-Advance, Inc.
14600 21st Avenue North
Plymouth, MN 55447-3408
www.nilfisk-advance.com
Phone: 800-989-2235
Fax: 800-989-6566
©2008 Nilfisk-Advance, Inc.