

# Commercial Equipment

Defining Cleaning Innovation



Upright Vacuums  
Canister & Specialty Vacuums  
Extractors / Carpet Equipment  
Sweepers  
Floor Machines  
Burnishers  
Automatic Walk-Behind Scrubbers  
Rider Scrubbers  
Wet/Dry Tank Vacuums  
All Purpose Cleaners  
Specialty Products  
Pressure Washers



Smart cleaning.

A Nilfisk-Advance Brand

# Upright Vacuums



## Vacuums for Every Cleaning Need

Whether your cleaning tasks call for a vacuum that's lightweight and easy to maneuver, a heavy-duty, large-area machine, or something in between — Advance has the answer. And your Advance representative has the expertise to help you choose the best models for your cleaning program, including vacuums that meet LEED-EB guidelines and the GS-42 green cleaning standards.

Advance's line of single-motor upright vacuums delivers effective and cost-efficient cleaning. You can look for the Carpet and Rug Institute (CRI) Green Label or Seal of Approval Certification on all Advance uprights. The CRI certification means the machine has passed independent tests verifying its ability to remove soil, contain dust and retain quality carpet appearance. Spectrum™ single motor and dual motor models are CRI certified and are designed to be easy-to-maneuver with better dirt pickup and better filtration at a better value.

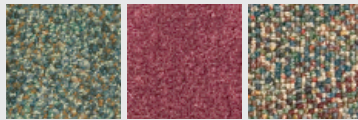

### ReliaVac® 12HP & 16HP

Single-motor  
Upright Carpet Vacuums

- 12 or 16 inch cleaning path
- High performance cleaning power with the aluminum brush roller
- Replaceable bristle strips and beater bars for versatile cleaning
- Removable clear fan cover allows for identifying and removing clogs
- Headlight illuminates work area



### Spectrum™ 12P & 15P

Single-motor  
Upright Carpet Vacuums

- 11.5 or 14.5 inch cleaning path
- Powerful 1,000 Watt, 2-stage motor
- Adjustable brush height
- Certified H.E.P.A. filtration standard
- Tools-free removable brush
- Heavy duty cord restraint
- Convenient front handle for lifting
- Accessories are conveniently tucked behind wand
- Sealed, maintenance-free cog belt



### ReliaVac® 12 & 12DC

Single-motor  
Upright Carpet Vacuums

- 12 inch path is cleaned with a durable steel brush roller
- ReliaVac® 12 top fill bag enhances vacuum power
- ReliaVac® 12 DC model has an easy to empty dirt cup
- Removable clear fan cover allows for identifying and removing clogs



### Advance CarpetTwin® 14 & 18

Dual-motor  
Upright Carpet Vacuums

- 14 or 18 inch cleaning path
- Separate vacuum and brush motors for a powerful performance
- Cleaning path is swept clean by the 5,000 rpm brush
- Converts to a canister vacuum for cleaning with the onboard tools
- Hospital-quiet at 69 dB A
- Indoor air quality is protected by the hospital grade exhaust filter

## PUMP-UP YOUR PRODUCTIVITY with Advance Cleaning Equipment

		
Advance CarpeTrier™ 28	Advance CarpeTwin® 14	Advance Spectrum™ 15D
<b>13,000</b> sq ft	<b>3,500</b> sq ft	<b>4,000</b> sq ft

Based on 1 hour cleaning time.

# Dual-Motor Upright Vacuums for Powerful, Efficient Pick-up

When your facility calls for daily use of a heavy-duty, long-life vacuum, Advance has the dual-motor upright for you. Our CarpeTwin® vacuums deliver thorough floor cleaning, plus all the tools you need for off-floor cleaning. These uprights feature hospital-quiet operation (69 dB A) and a MicroStat filter that captures more debris for a cleaner, healthier facility. Because of the many features designed for a green cleaning program, the CarpeTwin vacuum has received CRI Green Label certification. Built for one-pass cleaning, the CarpeTrier™ 28 vacuum is perfect for cleaning large areas. The chevron bristle pattern on this machine draws dirt to the vacuum intake for efficient cleaning. Operator fatigue is minimized with the CarpeTrier vacuum since the need for back and forth movement is eliminated.



## Spectrum™ 15D & 18D

Dual-motor  
Upright Carpet Vacuums

- 14.5 or 17.5 inch cleaning path
- Separate vacuum and brush motors for a powerful performance
- 1,350 Watts of power with combination of independent brush and vacuum motors
- Adjustable brush height with low brush height indicator light
- Certified H.E.P.A. filtration standard
- Tools-free removable brush
- Heavy duty cord restraint
- Convenient front handle for lifting
- Accessories are conveniently tucked behind wand
- Sealed, maintenance-free cog belt



## CarpeTrier™ 28

Large Area  
Upright Carpet Vacuum

- 28 inch cleaning path allows for increased productivity
- Dual vacuum motors provide generous pickup power
- Large 1 bushel capacity cloth bag is standard
- Carpet brush propels the machine, minimizing operator fatigue



## CarpeTwin® 16XP

Dual-motor  
Upright Carpet Vacuum

- 16 inch cleaning path is swept clean in one pass
- Durable construction allows for years of heavy-duty use
- 1 3/4 inch hose and wand are onboard for off-floor cleaning

## Canister & Specialty Vacuums



## Canister Vacuums for Maximum Cleaning Flexibility

Need to clean floors, plus walls, ceilings and other off-floor surfaces? Need to clean in occupied areas or during business hours? Then you need the flexible cleaning performance of canister vacuums from Advance. Canister vacs feature quiet operation and multi-level filtration systems for improved indoor air quality (IAQ). With their straight-forward design and few moving parts, canister vacuums minimize clogging and maximize reliability for the lowest total cost of ownership. The quiet, high-performance CaniStar® vacuum is CRI Green Label certified and features a superior filtration system – including a 2-ply dust bag, foam filter, multilayer paper filter and a motor protection filter. The versatile QuickStar™ vacuums clean carpet and hard floors as well as other horizontal and vertical surfaces. Their low center of gravity and three-point stance make them easy for any operator to maneuver. When cleaning a stairwell, elevator, entrance, or any other area where electricity is inaccessible, the QuickStar™ B battery vacuum provides best-in-class 60 minutes of continuous cleaning time. With a very low sound level of only 60 dB A, the QuickStar B can easily be used for daytime cleaning without disturbing occupants.

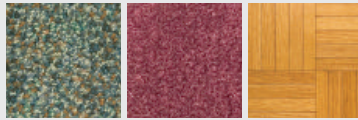

### QuickStar™

Canister Vacuum

- 1,100 Watt, 2 stage motor
- 62 dB A sound level
- Filter basket standard for bagless operation, six dust bags included, cloth shake out bag optional
- Three levels of filtration standard
- 33 foot cord, rotating dust brush and crevice tool stored onboard



### QuickStar™ B

Canister Vacuum

- 400 Watt, 2 stage motor
- Quiet 60 dB A sound level
- Powered by two lithium ion batteries
- Two batteries provide one full hour run time and require two hours to recharge
- Filter basket standard for bagless operation, six dust bags included, cloth shake out bag optional
- Three levels of filtration standard
- Rotating dust brush and crevice tool stored onboard



### CaniStar®

Canister Vacuum

- Super-quiet sound level for daytime cleaning – 53 dB A
- 1,100 Watt motor for superior suction and cleaning performance
- Built with serviceability in mind, to provide the lowest total cost of ownership
- Full complement of tools for commercial cleaning tasks
- Available H.E.P.A. filtration

# Backpack Vacuums for Reduced Operator Fatigue

Cleaning confined and cluttered office space, stairways and other obstructed areas has never been easier – when you choose a backpack vacuum from Advance. Never before has there been a backpack as comfortable and effective as the Adgility XP. The weight of the vacuum is distributed more evenly on the operator with the premium cushioned harness design on the Adgility XP. The vacuum moves with the operator when bending or twisting. The Adgility hip-style vacuum combines light weight with an ergonomic shape to create a new standard in comfort and performance. The Adgility hip-style vacuum has met CRI Green Label certification requirements, while the Adgility XP has received CRI Seal of Approval for vacuums certification.



## Adgility™

### Backpack Vacuum

- Lightweight at only 6.4 pounds
- Powerful 1,000 Watt motor generating 100 CFM and 96 inches of waterlift
- Three levels of filtration standard, H.E.P.A. filter optional
- 50 foot (15 m) safety yellow power cord for long cleaning reach
- Includes 12 inch combination floor tool, dust brush, crevice tool and six dust bags



## Adgility™ 6XP & 10XP

### Backpack Vacuums

- Comfortable, lightweight design
- Premium harnessing system
- Quiet 62 dB A sound level
- Cord restraint clips onto the safety cord and holds it in place
- Exhaust port directs warm air up and away from the operator
- SaniSeal™ self-sealing adhesive rim on bag seals to contain all dust and dirt
- Four levels of filtration, H.E.P.A. filter optional



## Advance Extractors are Industry Leading

From handy spot cleaners to innovative riding machines, Advance offers a complete line of carpet extraction equipment.

The Advance AquaSpot® carpet spot extractor works as a convenient, easy-to-use extractor for quick clean-up of spills or touch-ups on carpet or upholstery. The Advance AquaClean® line is one of the most popular extractors on the market. A self contained extractor, the AquaClean® provides superior cleaning results and leaves carpets nearly dry and ready to use. The Advance AquaPro® with AquaWand™ is available in three models, all with CRI Seal of Approval, to meet your various portable extractor needs. The AquaPLUS™ and AquaPLUS™ AXP™ battery extractors features *LIFT*™ Technology for low-moisture cleaning and fast dry times. Carpets are dry within 30 minutes when using AquaPLUS™ extractors with *LIFT*. The industry-leading Advance AquaRide® rider extractor also features *LIFT* Technology for low-moisture cleaning. The AquaRide® is also available with AXP™ Onboard Detergent Dispensing System.

With the complete line of extractors from Advance, carpets are cleaned better, faster, and easier, resulting in increased productivity.

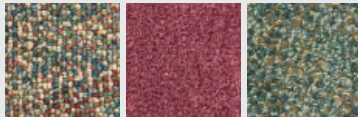

### AquaClean® 16ST/18ST/16XP/18FLX

Self-Contained Extractors

- Aerodynamically engineered vacuum shoe for constant acceleration and superb water recovery
- 1.5 three stage vacuum motor, 117 inches of waterlift, 50 foot (15 m) cord
- Brush and vacuum shoe removed without tools
- XP and FLX models include onboard spotting tool



### AquaClean® 12ST

Self-Contained Extractor

- Single nozzle spray system allows for even coverage over the cleaning path
- 5 gallon solution tank
- 12 inch cleaning path
- Single spray jet technology allows for even coverage over cleaning path



### Aquamatic™ Selectric

Automatic Extractor

- Self-propelling drive with four speeds for forward and reverse
- 25 gallon tank-in-tank design allows for a low profile
- 18 inch brush reverses for double scrubbing



### AquaPLUS™ & AquaPLUS™ AXP™

Carpet Extractors

- AXP™ Onboard Detergent Dispensing System (AquaPLUS™ AXP™)
- *LIFT*™ Technology for low-moisture cleaning
- One-Touch™ operation
- Deep Treat™ cleaning for pre-spray and post cleaning treatment



# Advance AquaRide® SE and AquaRide® AXP™ Increase Cleaning Productivity

Increase productivity by 400% compared to conventional walk-behind extractors with the Advance AquaRide®, the industry's first rider sweeper/extractor. With dual cylindrical technology for sweeping and extraction efficiency, Advance AquaRide® sweeps and extracts in one pass.

A wide 28 inch cleaning path and a 63 inch turning radius delivers superior cleaning results. The Advance AquaRide provides more than two hours of cleaning time per tank, combined with easy maintenance and low operator fatigue that add to the bottom line. Floors are left almost dry, reducing dry time significantly and allowing you to extract whenever your floors need it. The result is a reduced cost of cleaning.

AquaRide is available with AXP™ Onboard Detergent Dispensing System.



AquaRide® AXP™ model shown



## AquaPro® XP/H/C

Portable Extractor

- AquaWand™ cleaning tool standard on all models
- AquaWand™ design provides increased water pick-up with less time and effort
- AquaPro XP and H feature 212° solution at the wand tip
- AquaPro XP provides 300 psi for restoration or 75 psi for light duty cleaning
- AquaPro H and C provide 150 psi
- All models incorporate onboard storage of AquaWand™, detergent bottles, and other cleaning tools



AquaPro® XP - Gold  
AquaPro® H - Silver  
AquaPro® C - Bronze



## AquaSpot®

Carpet Spot Extractor

- A clear recovery tank with 2 dumping ports allows for ease of cleaning
- Exhaust air is filtered for maintaining indoor air quality
- Optional cart is designed with a tray and holds cleaning accessories



## HydroDry™

Dryer

- Durable rotocast polyethylene stackable blower with a 0.5 hp motor
- 3 speed settings to select the right amount of air movement
- Blower can be angled in three different positions to direct air as needed
- 25 foot power cord to reach those distant outlets



**LIFT™ low-moisture technology utilizes a patented indirect spray feature that provides superior cleaning while increasing per tank productivity and reducing water consumption. Operators will experience faster dry times and true cleaning with LIFT™ technology.**

## PUMP-UP YOUR PRODUCTIVITY with Advance Cleaning Equipment

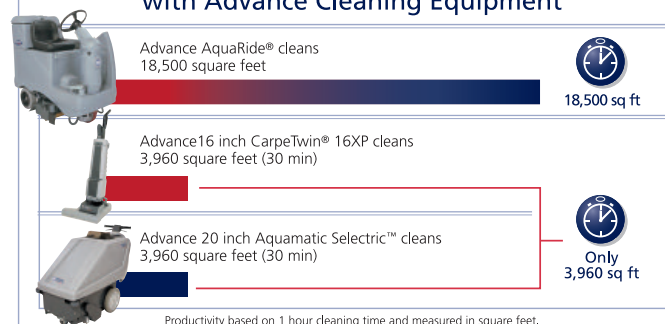

# Sweepers



## Advance Sweepers: the Fast Track to a Clean Sweep

From walk-behind to rider models, Advance sweepers provide superior cleaning results in a wide variety of applications and floor surfaces. Rated at only 59 dB A, the Advance Terra® 28B is one of the quietest battery operated sweepers in the industry. With A.S.A.P. (All Surface All Purpose) sweeping technology, the sweeping efficiency is maximized on the Terra® 28B when the operator transitions between hard and soft floor types. The Terra® 3700B rider sweeper offers a 37 inch sweep path for larger carpeted areas, while the Terra® 4300B is built for industrial strength sweeping – inside and out.

Advance sweepers feature tools-free maintenance and easy broom adjustments with operator-friendly controls. Recent product innovations include onboard battery chargers, maintenance-free gel batteries, and enhanced filtration.



### Advance Terra® 28B

Walk-Behind Sweeper

- 28 inch sweep path
- Maintenance free gel battery standard
- Half as loud as most vacuums at 59 dB A
- Standard onboard battery charger
- Tools-free removable brooms and hopper
- Rugged construction for carpet or hard floor applications



### Advance Terra® 3700B

Rider Sweeper

- 37 inch sweep path
- Battery operated
- Standard onboard battery charger
- Tools-free removable brushes and hopper
- Rugged construction for carpet or hard floor applications



### Advance Terra® 132B

Walk-Behind Sweeper

- 32 inch sweep path
- Battery operated
- Standard onboard battery charger
- Tools-free removable brushes and hopper
- Rugged construction for carpet or hard floor applications



### Advance Terra® 4300B

Rider Sweeper

- 43 inch sweep path, battery operated
- Automatic main broom height adjustment
- 20% gradeability while sweeping
- Rugged construction for multisurface floor cleaning

## PUMP-UP YOUR PRODUCTIVITY with Advance Cleaning Equipment

		
Advance Terra® 4300B	Advance Terra® 28B	36 Inch Push Broom
<b>48,840</b> sq ft	<b>20,000</b> sq ft	<b>5,600</b> sq ft

Based on 1 hour cleaning time.

## Advance Floor Machines Feature Easy Maintenance

Clean floors, both hard and soft, with a floor machine from Advance. The standard 175 rpm machines vary in size from 13-20 inches with motors ranging from 1 horsepower to 1.75 horsepower. All machines come standard with a safety switch and pad driver. A versatile two-speed floor machine operates at 175 and 275 rpm. To customize the cleaning capabilities of each machine, Advance provides a full line of accessories, including solution tanks, and a complete selection of pads and brushes. Advance floor machines operate efficiently, reliably and productively. Advance floor machines are made to the high standard of quality that you have come to expect from Advance.

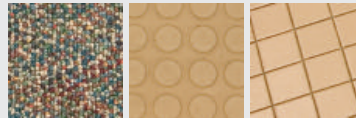

### **Pacesetter™ 20TS**

Two-Speed Floor Machine

- Versatile 20 inch two-speed floor machine
- 1.5 hp DC motor
- 66 frame motors run at 180 and 320 rpm
- Ergonomic molded handles for safety and comfort
- Pad driver included



### **Pacesetter™ 13/17/20/17HD/20HD/20SD**

Floor Machines

- 13, 17 and 20 have 1.0 hp, 66 frame motors at 175 rpm
- 17HD and 20HD have 1.5 hp, 66 frame motors at 175 rpm
- 20SD is 20 inches with 1.75 hp, 66 frame motor at 175 rpm
- Ergonomic molded handles for safety and comfort
- Pad driver included

## Burnishers



## Advance Burnishers Add Luster to Floors

Advance offers a complete line of burnishers available in cord electric, propane, and battery power sources. Two cord electric models offer exclusive, patented technology to eliminate any operational variances for almost foolproof burnishing. The dust collection model provides superior dust collection enabling one pass burnishing. Four propane models are available in two different sizes to match your application. Five battery burnishers are available: four walk-behind models and a rider. The walk-behind models are built to last, offering dual dust collection bags and adjustable pad pressure. Advance introduced the battery rider burnisher to the industry to further increase burnishing productivity. Rely on Advance burnishers for all of your burnishing needs.

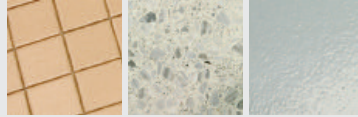

### Advolution™ 20

Cord Electric Burnisher

- 20 inch burnishing path, 1,500 r.p.m.
- Flex Floor Technology for constant even shine even on unlevel floors
- Patented gas spring provides optimal head pressure for maximum gloss performance
- EZ Store™ folding handle
- Rotating cord hook
- 75 foot safety yellow cord with hospital grade plug



### Advolution™ 20XP

Cord Electric Burnisher

- 20 inch burnishing path, 2,000 r.p.m. with dust control
- Flex Floor Technology for constant even shine even on unlevel floors
- Patented gas spring provides optimal head pressure for maximum gloss performance
- EZ Store™ folding handle
- Rotating cord hook
- 75 foot safety yellow cord with hospital grade plug
- Dual Port Dust Bag



### PBU Series 21 & 27

Propane Burnishers

- 20 and 27 inch burnishing paths available in a variety of models with either 1,500 or 2,100 r.p.m.
- Powerful 13 or 17 hp Twin-V engines
- Fastest high gloss burnishing available
- Rugged one piece cast deck & frame - powder coat finish resists damage
- Adjustable handle
- Available with or without dust control
- Available with Carb Gard™ emissions control
- Available with catalytic mufflers

# Advolution™ 2710 Maximizes the Shine in Less Time

The Advolution™ 2710 battery-powered rider burnisher from Advance is designed around a front steering system – accepted industry-wide as being the easiest to control and maneuver. A unique One-Touch™ control pad simplifies operator training and equipment operation.

The Advolution™ 2710 rider burnisher increases operator productivity with its ride-on capability and extended battery run-time. The burnishing pad operates at a speed of 1,600 rpms and utilizes three different pressure settings. On average, battery run-time on this rider burnisher allows the operator to burnish over 30,000 square feet (9,144 meters) per hour. Maximum tested productivity is even higher, with results exceeding 135,000 (41,148 meters) square feet on a single battery charge.



## Advolution™ 20B/20BT/24B/24BT

Battery-Powered Burnishers

- Pad assist model (20B/24B) or powered traction model (20BT/24BT) available
- Consistent and even polishing with self-regulating pad pressure
- Best passive dust control in the market, which helps improve indoor air quality
- Safety switch in pad change position
- Optional active dust control is available with the addition of an Adgility hip-style vacuum to the front of the machine



## Advolution™ 2710

Battery-Powered Rider Burnisher

- Ultra high productivity, six 6 Volt/395 Ah batteries
- 1,750 rpm, 3.25 hp motor produces an exceptional shine
- One-Touch™ burnishing with three pad pressure settings
- Passive dust control standard; active dust control optional for added filtration

## Why walk when you should ride?

Advolution™ 2710



**34,375**  
sq ft

Advolution™ 20XP



**10,000**  
sq ft

- Riding is safer than walking because of better sight lines
- Employees are less fatigued, which means they can clean longer and more areas
- Rider speed is faster than walking — employees can clean more square footage in less time!

*The Result? Increased productivity that drives down the cost to clean*

## Automatic Walk-Behind Scrubbers



## The Right Scrubber for a Spotless Facility

Advance leads the industry with the most innovative designs, unique features, and highest productivity in floor scrubbers today. That means more cleaning flexibility, longer machine run-time, easier operation, and maximum operator safety. All of Advance's automatic walk-behind scrubbers leave floors clean and dry in just one pass, increasing safety and productivity. Whether you're moving from mop-and-bucket cleaning to a small scrubber, or you require a high performance machine with the widest scrub path and newest technology available – Advance has the machine for you. Advance scrubbers offer Smart Solutions™ flow rate, onboard battery chargers, easy to use operator controls, and many more features for performance and safety. Most Advance scrubbers operate at a sound level of 65 dB A or less, making them ideal for daytime cleaning. They are also a great addition to any green cleaning program.

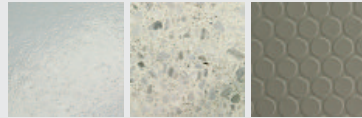

### Micromatic™ M17B/M17E

Automatic Scrubbers

- Gel batteries with onboard charger, on battery model
- Smart Solutions™ solution control
- 6-gallon solution and recovery tanks



### Micromatic™ 13E

Automatic Scrubbers

- Replaces mop and bucket cleaning
- 13 inch scrub path, cord-electric
- Dual 6.5 inch disc brushes operate at 200 rpm
- Front squeegee system picks up solution in all directions
- 1.8 gallon "lift-out" solution tank, and 2.1 gallon recovery tank



### Micromatic™ 14E

Automatic Scrubbers

- 14 inch scrub path, cord-electric
- Cylindrical scrub brush operates at 1,000 rpm
- Front and rear squeegee system picks up solution in all directions
- 3 gallon "lift-out" solution and recovery tanks



### Adfinity™ 17ST/20ST

Automatic Scrubbers

- 17 and 20 inch disc scrub path
- 10.5 gallon solution and recovery tanks
- Smart Solutions™ Flow Rate
- Onboard Battery Charger
- Variable Pad Pressure
- Tools-free removal of squeegee and squeegee blades

# Features that Make Scrubbing a Breeze

Many of our automatic scrubbers feature One-Touch™ operator controls for the easiest operation. They also feature an onboard battery charger for the quickest, most convenient charging option. To save water and detergent, we've designed all of our scrubbers with Smart Solutions™. This water-saving system guides the operator to select the right water and chemical flow rate for their cleaning needs, thereby optimizing water and chemical use. Along with Smart Solutions, our AXP™ Onboard Detergent Dispensing System is available on the Adfinity™, Convertamatic®, Warrior™ and Adgressor® scrubber lines, so there's no wasted detergent. The Advance line of walk-behind scrubbers is also equipped with features that make them easy to maintain. The Micromatic™ 14E features a "lift-out" solution and recovery tank, while the Adfinity™ line features a tip-back tank for full accessibility.



## Adfinity™ 20D/X20D/X20C/X24D

Automatic Scrubbers

- 20 and 24 inch disc and 20 inch cylindrical scrub paths, with traction drive
- 14.5 gallon solution and recovery tanks
- Smart Solutions™ Flow Rate
- AXP™ Onboard Detergent Dispensing System (X20D, X20C, X24D)
- Onboard Battery Charger
- Variable Pad Pressure (20D and X20D)
- Interchangeable Scrub Decks
- Tools-free removal of squeegee and squeegee blades



## Warrior™ ST & AXP

Automatic Scrubbers

- Available in 28 and 32 inch scrub paths
- 30 gallon solution and recovery tanks
- Tools-free interchangeable scrub decks
- Optional AXP™ Onboard Detergent Dispensing System



## Convertamatic® 24/26/28 C/D & 32D

Automatic Scrubbers

- Available in 24, 26 or 28 inch cylindrical and 24, 26, 28, or 32 inch disc scrub paths
- 20 gallon solution and recovery tanks
- Convertamatic® AXP™ available with factory installed AXP™ Onboard Detergent Dispensing System on all sizes
- One-Touch™ scrubbing and programmable operator controls

# Rider Scrubbers



## Choose a Rider Scrubber for Increased Productivity

Need to clean large areas fast? Advance has rider scrubbers for your biggest scrubbing jobs. The Advenger® rider scrubber can clean up to 31,500 square feet an hour and features 28 gallon solution and recovery tanks, which extend cleaning time. The Advenger is the first automatic rider-scrubber that gives you complete control of how you clean. The secret is the EcoFlex™ System - a flexible cleaning solution that meets all of your floor cleaning needs, from green to clean. EcoFlex System lets the operator clean with plain water wherever and whenever possible. An ultra-low detergent ratio should be used for normal, routine cleaning. The operator can easily and temporarily increase the cleaning power of the machine with a 60 second burst of power. The dirtiest of floors can be cleaned with full strength detergent, if needed. Your operators will love the Advenger for its ride-on design and low sound level. With an industry leading 63 inch aisle turning radius and the ability to fit through a standard doorway, the Advenger rider scrubber can go anywhere.

The Advance 2800 ST and 3400 ST scrubbers deliver high performance results on a back-to-basics rider-scrubber platform. Manual control of the scrub deck and squeegee replace intricate electronics to keep operation simple without sacrificing performance.

For even bigger cleaning jobs, Advance's Adgressor® rider scrubber is built tough, offering scrub deck options of either 35 or 38 inches wide and cleaning up to 46,200 square feet per hour. Both the Advenger and Adgressor offer interchangeable scrub decks that let you change between disc and cylindrical decks, for maximum cleaning flexibility.

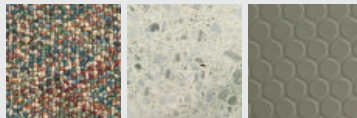

### Advenger® & Advenger® with EcoFlex™ System

Rider Automatic Scrubbers

- Green cleaning and high productivity technology standard
- Optional EcoFlex™ System reduces environmental impact and detergent costs
- Tools-free interchangeable scrubs decks - 28 inch (71 cm) and 34 inch (86 cm) disc or 28 inch (71cm) cylindrical
- 28 gallon (106 L) solution and recovery tanks with Total Clean® technology
- One-Touch™ scrubbing with calibrated brush pressure and solution flow
- Patented Safe 'N Dry™ rear squeegee system



### 2800 ST & 3400 ST

Rider Scrubbers

- Tools-free interchangeable scrubs decks - 28 inch (71 cm) and 34 inch (86 cm) disc
- 28 gallon (106 L) solution and recovery tanks with Total Clean® technology
- Manual control of the scrub deck and rear squeegee eliminates complicated control boards
- Simplified one button control panel with minimal electronics
- Patented Safe 'N Dry™ rear squeegee system



### Adgressor® & Adgressor® AXP™

Rider Automatic Scrubbers

- Available in 35 or 38 inch disc scrub paths
- Easy to clean 42 gallon solution and recovery tanks
- 36 Volt battery system
- Rugged design with heavy gauge steel chassis and metal bumper
- Adgressor® AXP™ available with factory installed AXP onboard detergent dispensing system on 28 and 32 inch sizes
- Battery watering system standard on AXP machines; Kit available as an option on non AXP machine

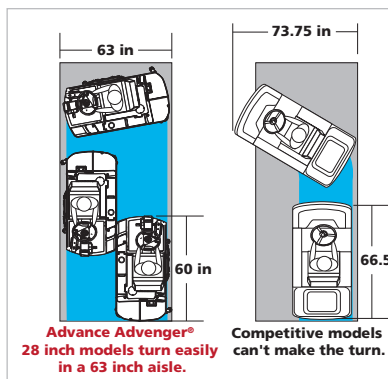

### PUMP-UP YOUR PRODUCTIVITY with Advance Cleaning Equipment

Advance 28 in Advenger® Rider Scrubber	Advance 24 in Convertamatic®	Advance Adfinity™ 20ST
<b>20,410</b> sq ft	<b>11,130</b> sq ft	<b>6,969</b> sq ft

Based on ISSA practical numbers.

# AXP™ Onboard Detergent Dispensing System Saves Work, Waste and the Environment

What if your cleaning equipment could mix its own cleaning solution, combining the right amounts of detergent and clean water no matter what detergent brands you use? What if the detergent and clean water were never mixed until just before the solution was sprayed on your floor, so there's no unused solution to dispose of?

If you're looking for an additional way to increase cleaning productivity, then it's time to try Advance's patented AXP™ onboard detergent dispensing system. With the AXP system, detergent is precisely dispensed at the manufacturers' recommended dilution rate and combined with clean water at the scrub deck – just before the cleaning solution is applied to the floor. You eliminate solution tank cleaning, as well as cross contamination between detergents or between clean and dirty solutions. Using a machine with AXP also allows you the convenience and flexibility to switch between multiple detergents within seconds, while minimizing operator exposure to potentially harmful cleaning chemicals.



## See the annual savings with the AXP™ Onboard Detergent Dispensing System compared with conventional methods:

### Annual Budget: Walk-behind Scrubber

Conventional	136 gallons DETERGENT (\$1092)
<b>AXP*</b>	<b>68 gallons DETERGENT (\$546)</b>
Conventional	801 hours LABOR (\$8010)
<b>AXP*</b>	<b>692 hours LABOR (\$6920)</b>
Conventional	17,472 gallons WATER
<b>AXP*</b>	<b>8,736 gallons WATER</b>

\* Based on Convertamatic® 26 D/C AXP used to clean a 35,000 sq. ft. facility, 5 times per week.

### Annual Budget: Rider Scrubber

Conventional	166 gallons DETERGENT (\$1328)
<b>AXP*</b>	<b>83 gallons DETERGENT (\$664)</b>
Conventional	742 hours LABOR (\$7420)
<b>AXP*</b>	<b>624 hours LABOR (\$6240)</b>
Conventional	21,250 gallons WATER
<b>AXP*</b>	<b>10,625 gallons WATER</b>

\* Based on Advenger® 2810 AXP used to clean a 45,000 sq. ft. facility, 5 times per week.

### Technical Specifications

Refillable Cartridge Capacity	1.25 gal (4.75 L)
Available Dilution Rates	32:1, 50:1, 64:1, 100:1, 128:1, 150:1, 200:1 and 300:1
Low Detergent Warning	Standard (on walk-behind models)

Specifications are subject to change without notice.



## AXP™ is available on the following:



Adfinity™



Convertamatic®



Warrior™



AquaPLUS™



AquaRide®



Adgressor®



Adphibian™

## Wet/Dry Tank Vacuums



### Advance Wet/Dry Vacuums for Daily Use

Wet messes, dry dirt, or somewhere in between, Advance has the right wet/dry tank vacuums for almost any daily cleaning challenge.

Known throughout the industry for rugged reliability, versatile Sprite® vacuums excel in wet and dry applications. Used daily in commercial and government buildings, schools, shopping malls, airports and healthcare facilities, operators can count on Sprite for many years of service.

The AWD is available with an optional front air scoop kit. Lightweight and compact, the AWD is ideal for transporting between facilities.

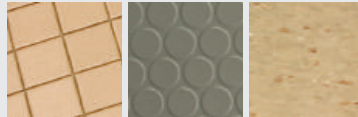

### Sprite® Air Scoop™ 12 & 16

Wet/Dry Tank Vacuums

- 24 inch front mount squeegee standard, tools are separate
- 1.3 hp 2 stage motor, waterlift 88 inch, 91 CFM, 73 dB A
- Empty by tip-and-pour or front drain hose, 50 foot cord
- Removable tank for easy cleaning

### AWD w/ and w/o Air Scoop™

Wet/Dry Tank Vacuums

- Available in 20 and 15 gallon sizes, with compact footprint to take up minimal room in tight spaces
- Front mount squeegee optional in 24 inch or 30 inch sizes
- Adjustable handle folds over machine for easy transport
- Optional H.E.P.A. filtration available

# Touchless Cleaning for Increased Productivity

Advance's All-Purpose Cleaning Systems offer touch-less cleaning that is up to three times faster than traditional methods. Advance's Micro Cleaner™ and All Cleaner™ answer the call for an affordable, touch-less approach to cleaning restrooms and other areas with hard surfaces. You'll improve productivity and see better results – now that's smart cleaning.

When it comes to versatility, the All Cleaner makes the most of its small design. Its open chemical system allows use of any two chemical bottles (including green cleaning approved solutions) and controls the dilution rate for the proper application each time. And whether your bottle is round or rectangle, it will fit in the holding wells on both the Micro Cleaner and All Cleaner.

For hard surface cleaning where solution recovery is not required, the Micro Cleaner™ utilizes micro-fiber mops that absorb solution while you clean. The result is a more maneuverable unit in a smaller and even more affordable package. And just like the All Cleaner™, you'll save precious storage space in your equipment closet because of its small size.



### Micro Cleaner™

All-Purpose Cleaner

- Compact and maneuverable
- Unique spray only design utilizes micro fiber mops for water pick-up
- 20 gallon solution tank
- 150 psi application flow
- Onboard storage for standard accessories
- 2 chemical metering system with universal chemical storage
- Removable pallette contains all electrical components



### All Cleaner™

All-Purpose Cleaner

- Compact and maneuverable
- 20 gallon solution and 12 gallon recovery tanks
- 2 chemical metering system with universal chemical storage
- 200 psi application flow
- Optional front mount squeegee for easy water pick-up
- Simple storage for recovery and solution hose
- Removable pallette contains all electrical components



### Reel Cleaner®

All-Purpose Cleaner

- 25 gallon clean water tank
- Onboard storage for standard accessories
- Any shape chemical bottle fits on the machine
- Clean water gauge for emptying and monitoring tank
- Clam-shell design for ease of servicing
- 2 chemical metering system
- Low profile and compact design for ease of transporting

Increases productivity by 300% compared to manual wipe-downs.



By Hand  
**27**  
minutes



With Advance Reel Cleaner™  
**9**  
minutes



## Adphibian™ Multi-Surface Extractor-Scrubber

Building service contractors and in-house cleaners need equipment solutions that meet the multiple cleaning demands they face today. The Advance Adphibian™ multi-surface extractor/scrubber is the answer. The Adphibian™ cleans both soft and hard floor surfaces. Maximum efficiency and flexibility are gained because cleaning staff are able to go from pre-spraying and extracting on carpeted floors, to scrubbing hard floors with just one machine.

Within 30 seconds, and with no tools required, the Adphibian's new patent-pending technology allows operators to switch between a full-functioning carpet extractor and a full-functioning cylindrical scrubber. And, the specially designed anti-microbial brushes are effective on all surface types.

## Dust Magnet™ Dry Dust Mopping System

Advance's Dust Magnet™ is a statically charged dry dusting system that attracts dust like a magnet. Disposable dusting sheets eliminate the mess, laundry and chemical expense you get with other dust mops.



### Adphibian™

Multi-Surface Extractor-Scrubber

- Full function extractor and scrubber with AXP™ Onboard Detergent Dispensing System
- Single deck, less than 30 seconds to change from extracting to scrubbing
- CRI SOA Approved Deep Cleaning Extractor in both *LIFT*™ low-moisture and restoration cleaning modes
- *LIFT*™ Technology for low-moisture cleaning
- Dual, anti-microbial counter rotating brushes with debris collection hopper
- Brushes, squeegee and vacuum shoes are removable without tools



### Dust Magnet™

Dry Dust Mopping Systems

- Dry dusting system uses disposable dusting sheets
- Super lightweight aluminum system
- Simple static electricity attracts dust and holds it
- 23, 46 and 59 inch wide cleaning path options
- Sheets come in convenient pre-cut boxes of 200, or a continuous roll of 100 sheets



### AdSpray™ 1500A

Pressure Washer

- 2 gpm and up to 1,450 psi
- 2 hp electric motor
- Includes: Hose, spray gun and wand, chemical injector and thermal valve



### AdSpray™ 1000XPC

Pressure Washer

- Cart mounted electric pressure washer available with a 1.5 hp electric motor
- 2.2 gpm and up to 1,000 psi
- Handles up to 140° F
- Includes: Hose, spray gun and wand, chemical injector and thermal valve

## **Nilfisk** *Genuine OEM Parts*

Keeping your equipment working effectively is essential for superior cleaning. Advance provides manufacturing parts and components through Nilfisk Genuine OEM Parts to help keep your Advance products working at peak performance. OEM parts are designed and built for our machines so they can be counted on to maintain our machines. They are value priced and quality built. By choosing Nilfisk Genuine OEM Parts, you can be certain you're getting the quality part you need for your machine.

---

## **Sustainability**

Nilfisk-Advance's fundamental attitude to the working environment and pollution is in accordance with the first principle of the United Nations conference declaration on Environment and Development (Rio, 1992):

"People are entitled to a healthy and productive life in harmony with nature."

---

### **Our environmental policy states, among other things:**

- the employees shall have a safe, healthy, motivating and inspiring working environment
  - the utilization of resources shall be continuously improved
  - our production must be controlled, including development, sourcing and deliveries, in order to minimize environmental impact
- 

### **We actively participate in manufacturing practices that are environmentally friendly, including:**

- recycling and reuse of our rotomold plastic, giving it new use as battery tray housing
- recycling of all metals, aluminum, cardboard and batteries
- efficient lighting in our corporate and manufacturing facilities that use less electricity
- equipment design technology that minimizes the amount of water needed to clean



Advance products are manufactured by Nilfisk-Advance Inc., the world's largest designer and manufacturer of high quality commercial and industrial floor maintenance equipment.

### **Quality**

A quality approach to cleaning is the commitment we make to every one of our customers. Along with each machine comes pride, craftsmanship, innovative technology, professional expertise and an international network of parts, maintenance and service support professionals.

### **Reducing the Cost to Clean**

Every aspect of our business revolves around creating cleaning solutions that generate superior cleaning results, increase productivity and reduce the cost of ownership. The result is superior cleaning products that drive down the cost of cleaning. The pride we take in production and service will become your pride of ownership when you buy Advance equipment.

**At Advance, we are defining cleaning innovation.**



recyclable

©2010, Nilfisk-Advance, Inc., Printed in U.S.A., Form L1587A 1-8-10

14600 21st Avenue North  
Plymouth, MN 55447-3408  
[www.advance-us.com](http://www.advance-us.com)  
Phone 800-850-5559  
Fax 800-989-6566

240 Superior Boulevard  
Mississauga, Ontario, Canada L5T 2L2  
[www.nilfisk-advance.com](http://www.nilfisk-advance.com)  
Phone 800-668-8400  
Fax 800-263-5111

