

PBU Series 21 & 27

Propane Powered Burnishers



The new Advance PBU series propane-powered burnishers are loaded with performance features to make your floors shine in less time.

The PBU series provides the fastest high-gloss burnishing available. The Advance PBU 21 has a 21 inch (53 cm) pad size and can burnish up to 25,000 square feet (2,322 m²) per hour, while the PBU 27 model offers a larger 27 inch (68 cm) pad capable of burnishing up to 33,000 square feet (3,066 m²) per hour. Simple controls ensure your operators won't be slowed down with machine adjustments — just start it and go.

Powerful 603cc Twin-V engines provide the torque to drive the pad at a high rpm that produces a sparkling shine. A catalytic muffler is standard on all models. Select models offer a heavy-duty seal on the shroud that provides the best dust control on the market, a clutch that permits the pad to only turn when the machine is moving, and CARB Gard™, a device that shuts off the engine if it detects harmful emission levels.

Easy pad changing, low maintenance and rugged dependability round out the benefits of choosing the new Advance PBU series of propane-powered burnishers.

Typical Applications Include

- Large Retail Stores
- Shopping Malls
- Supermarkets
- Government Facilities
- Educational Facilities
- Airports

Machine Options Include

- Dust-control
- Automatic shut-down
- Electric clutch

PBU Series 21 & 27

Propane Powered Burnishers

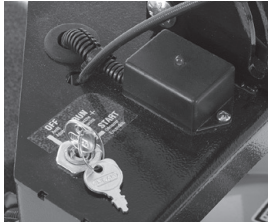

CARB Gard™ emissions control will stop an engine with high exhaust emissions. Notification LED is in plain view to the operator.



The operator throttle is conveniently located on the handle.

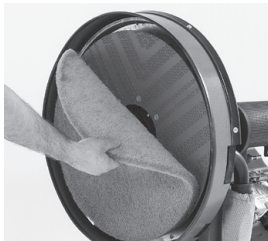

Easy access to change pads.



80% safety fill type propane tank.



The Dust Control series offers a unique floating shroud that directs the high velocity airflow near the floor to collect six times as much dust as competitive models.

- 1 Ergonomic handle for operator comfort
- 2 Adjustable handle for operator comfort
- 3 Electric key start
- 4 Fuel lock off & check valve for added safety
- 5 Easy change tank
- 6 Simple oil drain for easy maintenance
- 7 Rugged one piece cast deck & frame - powder coat finish resists damage
- 8 Heavy duty, permanently lubricated, sealed bearings
- 9 Toe kick design for under counter access

Two-year warranty

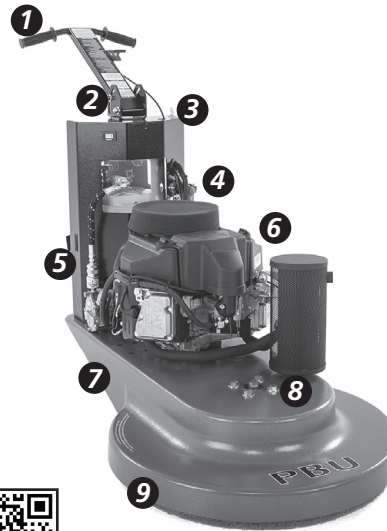

Defining Cleaning Innovation...

- Our products are designed using innovative technology that increases productivity and drives down the cost to clean.
- You can get expert service and maintenance for your Advance machines from factory-trained personnel around the world. Fast parts delivery, too.
- Maintain peak performance with Nilfisk Parts.

Technical Specifications

Models	21KACAT*	27KACAT*	21KACATCLDC	27KACATCLDC
Pad Size	21 in (53 cm)	27 in (68 cm)	21 in (53 cm)	27 in (68 cm)
Engine	603cc Kawasaki V-Twin	603cc Kawasaki V-Twin	603cc Kawasaki V-Twin	603cc Kawasaki V-Twin
Catalytic Muffler	Yes	Yes	Yes	Yes
CARB Gard™	No	No	Yes	Yes
Clutch	No	No	Yes	Yes
Pad Speed	2,000 rpm	1,700 rpm	2,000 rpm	1,700 rpm
Propane Tank	20 lb (9.1 kg) Capacity 80% Safety fill	20 lb (9.1 kg) Capacity 80% Safety fill	20 lb (9.1 kg) Capacity 80% Safety fill	20 lb (9.1 kg) Capacity 80% Safety fill
Auto Fuel Shutoff	Yes	Yes	Yes	Yes
Hour Meter	Yes	Yes	Yes	Yes
Sound Level	< 89 dB A	< 89 dB A	< 89 dB A	< 89 dB A
Productivity Rate	25,000 ft ² /hr (2,322 m ² /hr)	33,000 ft ² /hr (3,066 m ² /hr)	25,000 ft ² /hr (2,322 m ² /hr)	33,000 ft ² /hr (3,066 m ² /hr)
Agency Approvals	EPA & C.A.R.B.	EPA & C.A.R.B.	EPA, C.A.R.B., & CSA Listed	EPA, C.A.R.B., & CSA Listed
C.A.R.B. Certified (California Air Resources Board)	Yes	Yes	Yes	Yes
Weight	221 lb (100 kg)	233 lb (106 kg)	241 lb (109 kg)	268 lb (122 kg)
Dimensions				
Length	56 in (142.4 cm)	61.5 in (156 cm)	56 in (142.4 cm)	61.5 in (156 cm)
Width	23.5 in (60 cm)	30.5 in (77.5 cm)	24.5 in (62 cm)	31.5 in (80 cm)
Height	39.5 in (100 cm)	41 in (104 cm)	39.5 in (100 cm)	41 in (104 cm)
Warranty	2 Years Parts and Labor	2 Years Parts and Labor	2 Years Parts and Labor	2 Years Parts and Labor
Model Numbers	56384165	56384166	56384167	56384168

Specifications are subject to change without notice.

*21KACAT and 27KACAT are not available for sale in Canada.

Nilfisk, Inc.

9435 Winnetka Avenue North
Brooklyn Park, MN 55445
www.advance-us.com
Phone 800-850-5559
Fax 800-989-6566

240 Superior Boulevard
Mississauga, Ontario, Canada L5T 2L2
www.nilfisk-advance.ca
Phone 800-668-8400
Fax 800-263-5111

