

FM810™ ST & XP

Floor Machines



Advance

FACT SHEET



INTRODUCING THE ADVANCE FM810™

The next evolution of Advance orbital scrubbing floor machines is here: the Advance FM810™. The FM810 floor machine delivers the ultimate combination of ease of use and versatility for unmatched cleaning performance in both wet and dry applications. Available in both a standard ST model and a deluxe XP model packed with exclusive patent-pending features geared to BSCs and other power users.

Elevating Power

Featuring a full 1.5 horsepower motor, 160 pounds of down pressure and a 3,540 RPM pad driver, the FM810 is designed to get cleaner floors in fewer passes. That means operators aren't just getting the floors clean or stripped faster—they are also able to do it with less labor.

Expanding Applications

- Easily reach small, hard-to-reach areas where large automatic scrubbers will not fit or don't make sense.
- Supplement Advance REV™ machines to complete chemical-free floor finish removal projects in all areas of a room.
- Leverage standardized 14 x 20 inch pad deck to attach pads for cleaning grout in bathrooms, prepping gym floors for recoats, bonnet cleaning carpet, and even burnishing terrazzo, marble, and concrete.

ACCESSORIES AND OPTIONS

- 3M SPP Pads
- Red Scrub Pads
- Blue Scrub Pads
- Black Scrub Pads
- Carpet Bonnet
- Grout Pad
- Diamond Pads
- Sand Screens
- Dust Containment Kit
- Solution Tank Kit
- Baseboard Cleaner (FM810™ XP Standard)

TYPICAL APPLICATIONS INCLUDE

- Supermarkets
- Schools and Universities
- Hospitals
- Office Buildings
- Hotels / Motels
- Heavy Manufacturing Plants
- Bathrooms
- Gymnasiums



Advance FM810™ ST & XP

Floor Machines

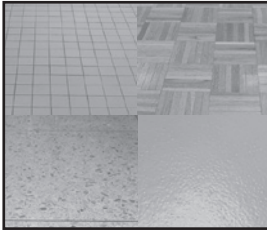

Use 3M™ SPP or Diamond Pads to abrade a wide variety of floor surfaces.

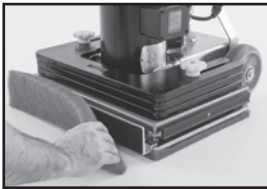

The FM810 XP comes with an innovative baseboard cleaner attachment as a standard feature. This simple device easily attaches to the front of the machine to provide a convenient alternative for cleaning baseboards without having to purchase a separate machine, or worse, getting down on your hands and knees to scrub.



Full Modularity for Easy Transport – The FM810 XP is fully modular to allow BSCs and other operators who frequently lift and transport their equipment between job sites to separate it without tools into more manageable pieces. Each modular attachment component is painted bright yellow for easy identification, making disassembly and reassembly a breeze.

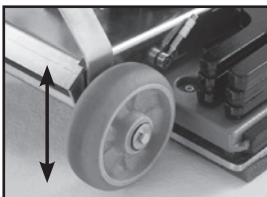

Switchable Modes – Easily switch between operating modes with the wheels up or on the floor. When the wheels are up, the FM810 XP provides the full-directional, high maneuverability of traditional floor machines. When the wheels are down, it delivers the high productivity forward-and-backward motion like a burnisher, giving you control so balanced that you can operate it with one hand, and not get fatigued.

FM810™ XP: Deluxe Features – The FM810 XP (shown) adds an additional package of innovative features that enhance ease of use, functionality and transport.

- 1 Baseboard cleaner
- 2 Three 21 pound weights
- 3 Adjustable, detachable handle
- 4 Safety switch protects against unintended machine start-ups
- 5 1.5 hp heavy duty motor driving a 3,540 rpm orbital deck
- 6 6 inch wheels can be raised or lowered for ease of use, functionality and transportation

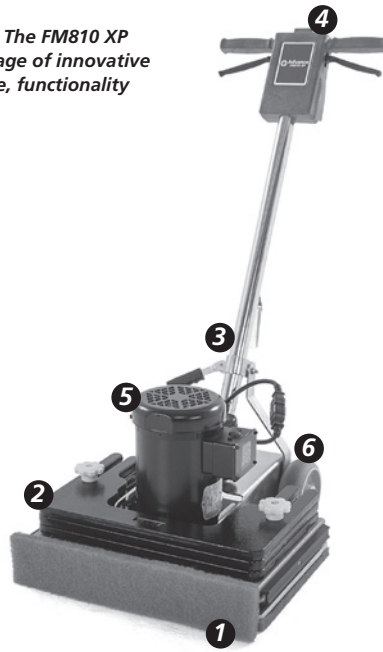

Defining Cleaning Innovation...

- Our products are designed using innovative technology that increases productivity and drives down the cost to clean.
- You can get expert service and maintenance for your Advance machines from factory-trained personnel around the world. Fast parts delivery, too.
- Maintain peak performance with Nilfisk Parts.

Technical Specifications

Models	FM810™ ST	FM810™ XP
Cleaning Pad Size	14 in x 20 in	14 in x 20 in
Motor	1.5 hp	1.5 hp
Voltage/Frequency	120 V / 60 Hz	120 V / 60 Hz
Orbit Speed	3,540 rpm	3,540 rpm
Orbit Diameter	1/4 in (6.4 mm)	1/4 in (6.4 mm)
Power Cable	50 ft (15 m), 14/3 Safety Yellow	50 ft (15 m), 14/3 Safety Yellow
Sound Level	68 dB A	68 dB A
Machine Total Weight	161 lb (73 kg)	169 lb (76.7 kg)
Machine w/o Weights	98 lb (44.5 kg)	106 lb (48 kg)
Weights	63 lb (28.5 kg)	63 lb (28.5 kg)
Dimensions (L x W x H)	20 in x 20.5 in x 44 in	20.75 in x 20.5 in x 44.5 in
Warranty	3 Years Parts, 2 Years Labor	3 Years Parts, 2 Years Labor
Additional Standard Features	Three 21 lb Weights Safety Switch 5 in Wheels Wheels-Up Only	Three 21 lb Weights Safety Switch 6 in Wheels Wheels-Up/Wheels-Down Baseboard Cleaner Detachabile Handle
Options	Dust Containment Kit Solution Tank Kit Baseboard Cleaner	Dust Containment Kit Solution Tank Kit
Accessories	3M SPP Pads, Red Scrub Pads, Blue Scrub Pads, Black Scrub Pads, Carpet Bonnet, Grout Pad, Diamond Pads, Sand Screens – Both Models	
Part Number	56105614	56105616

Specifications are subject to change without notice.



9435 Winnetka Avenue North
Brooklyn Park, MN 55445
www.advance-us.com
Phone: 800-850-5559
Fax: 800-989-6566

240 Superior Boulevard
Mississauga, Ontario, Canada L5T 2L2
www.nilfisk-advance.ca
Phone: 905-564-1149 or 800-668-8400
Fax: 905-564-1030 or 800-263-5111



©2015, Nilfisk, Printed in U.S.A.,
Form L3408A, 5-15

