

Reel Cleaner™

Instructions for use

Instructions for Use
Original Instructions

3/2003 revised 9/2017 REV B
Form no. 56041549

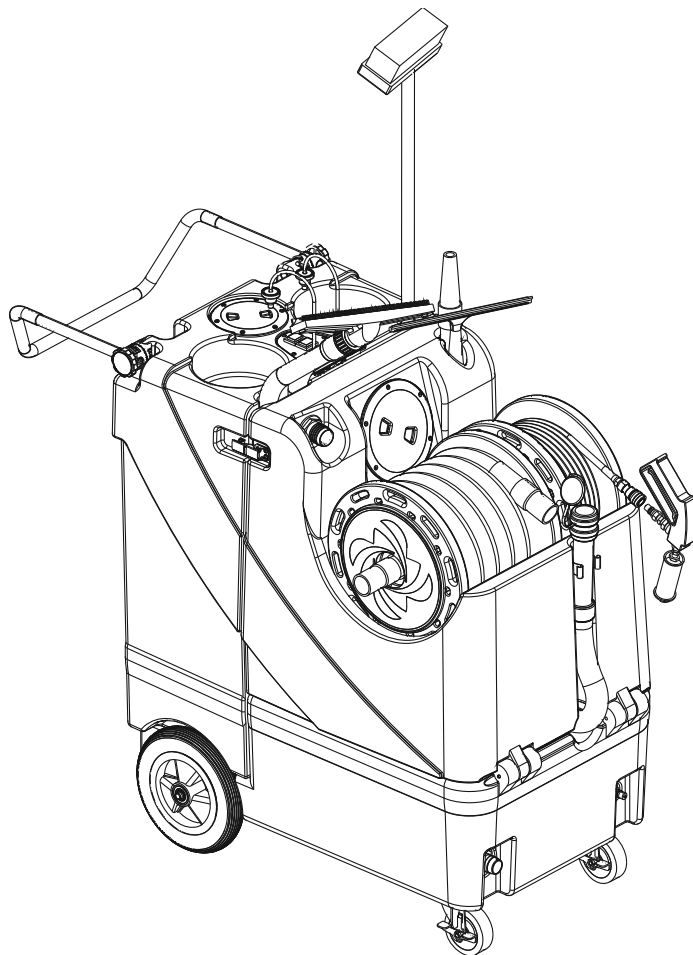
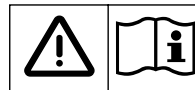

ADVANCE Model No:
56108050

IMPORTANT SAFETY INSTRUCTIONS

This machine is only suitable for commercial use, for example in hotels, schools, hospitals, factories, shops and offices other than normal residential housekeeping purposes.

When using an electrical appliance, basic precautions should always be followed, including the following:

READ ALL INSTRUCTIONS BEFORE USING THIS APPLIANCE.

WARNING!

To reduce the risk of fire, electric shock, or injury:

- Do not leave the appliance when it is plugged in. Unplug the unit from the outlet when not in use and before servicing.
- To avoid electric shock, do not expose to rain. Store indoors.
- Do not allow to be used as a toy. Close attention is necessary when used near children.
- Use only as described in this manual. Use only the manufacturer's recommended attachments.
- Do not use with damaged cord or plug. If the appliance is not working as it should be, has been dropped, damaged, left outdoors or dropped into water, return it to a service center.
- Do not pull or carry by the cord, use the cord as a handle, close a door on the cord, or pull the cord around sharp edges or corners. Do not run the appliance over the cord. Keep the cord away from heated surfaces.
- Do not unplug by pulling on the cord. To unplug, grasp the plug, not the cord.
- Do not handle the plug, cord or appliance with wet hands.
- Do not put any object into openings. Do not use with any opening blocked; keep free of dust, lint, hair, and anything that may reduce air flow.
- Keep loose clothing, hair, fingers, and all parts of body away from openings and moving parts.
- Do not pick up anything that is burning or smoking, such as cigarettes, matches, or hot ashes, or any health endangering dusts.
- Turn off all controls before unplugging.
- Use extra care when cleaning on stairs.
- Do not use to pick up flammable or combustible liquids such as petrol or use in areas where they may be present.
- If foam or liquid comes out with the vacuum exhaust, switch power off immediately. Verify that there are no foreign objects obstructing the float ball from moving freely. Contact Nilfisk-Advance if the problem persists.
- Liquid ejected at the spray nozzle could be dangerous as a result of its temperature, pressure or chemical content.

SAVE THESE INSTRUCTIONS

IMPORTANTES MESURES DE SÉCURITÉ

Cette machine ne convient qu'à un usage industriel, par exemple dans des hôtels, écoles, hôpitaux, usines, boutiques et bureaux et autres à l'exclusion de tout usage de maintenance résidentielle normale.

L'utilisation d'un appareil électrique demande certaines précautions:

LIRE TOUTES LES INSTRUCTIONS AVANT DE FAIRE FONCTIONNER CET APPAREIL

AVERTISSEMENT !

Pour réduire les risques d'incendie, de choc électrique ou de blessure:

- Ne pas laisser l'appareil sans surveillance lorsqu'il est branché. Débrancher lorsque l'appareil n'est pas utilisé et avant l'entretien.
- Pour réduire les risques de choc électrique, utiliser à l'intérieur seulement.
- Ne pas permettre aux enfants de jouer avec l'appareil. Une attention particulière est nécessaire lorsque l'appareil est utilisé par des enfants ou à proximité de ces derniers.
- N'utiliser que conformément à cette notice avec les accessoires recommandés par le fabricant.
- Ne pas utiliser si le câble ou la fiche est endommagé. Retourner l'appareil à un atelier de réparation s'il ne fonctionne pas bien, s'il est tombé ou s'il a été endommagé, oublié à l'extérieur ou immergé.
- Ne pas tirer soulever ou traîner l'appareil par le câble. Ne pas utiliser le câble comme une poignée, le coincer dans l'embrasure d'une porte ou l'appuyer contre des arêtes vives ou des coins. Ne pas faire rouler l'appareil sur le câble. Garder le câble à l'écart des surfaces chaudes.
- Ne pas débrancher en tirant sur le câble. Tirer plutôt la fiche.
- Ne pas toucher la fiche ou l'appareil avec des mains humides.
- N'insérer aucun objet dans les ouvertures. Ne pas utiliser l'appareil lorsqu'une ouverture est bloquée. S'assurer que de la poussière, de la peluche, des cheveux ou d'autres matières ne réduisent pas le débit d'air.
- Maintenir les cheveux, les vêtements amples, les doigts et toutes les parties du corps à l'écart des ouvertures et des pièces mobiles.
- Ne pas aspirer de matières en combustion ou qui dégagent de la fumée, comme des cigarettes, des allumettes ou des cendres chaudes.
- Mettre toutes les commandes à la position ARRÊT avant de débrancher l'appareil.
- User de prudence lors du nettoyage des escaliers.
- Ne pas aspirer des liquides inflammables ou combustibles, comme de l'essence, et ne pas faire fonctionner dans des endroits où peuvent se trouver de tels liquides.
- Si de la mousse ou un liquide s'échappe avec l'air évacué, mettez immédiatement l'aspirateur hors tension. Assurez-vous qu'aucun corps étranger n'empêche le flotteur de se déplacer librement. Si le problème persiste, contactez Nilfisk.
- Le liquide qui sort de l'embout de vaporisation peut s'avérer dangereux en raison de sa température, de sa pression ou du produit chimique qu'il contient.

CONSERVER CES INSTRUCTIONS

120VAC GROUNDING INSTRUCTIONS

This appliance must be grounded. If it should electrically malfunction, grounding provides a path of least resistance for electric current to reduce the risk of electric shock. This appliance is equipped with a cord having an equipment-grounding conductor and grounding plug. The plug must be plugged into an appropriate outlet that is properly installed and grounded in accordance with all local codes and ordinances.

DANGER!

Improper connection of the equipment-grounding conductor can result in a risk of electric shock. Check with a qualified electrician or service person if you are in doubt as to whether the outlet is properly grounded. Do not modify the plug provided with the appliance. If it will not fit the outlet, have a proper outlet installed by a qualified electrician.

This appliance is for use on a nominal 120-volt circuit, and has a grounding plug that looks like the plug illustrated in Figure 1 below. A temporary adapter illustrated in Figures 2 and 3 may be used to connect this plug to a 2-pole receptacle as shown in Figure 2 if a properly grounded outlet is not available. The temporary adapter should be used only until a properly grounded outlet (Figure 1) can be installed by a qualified electrician. The green-colored rigid ear, tab, or the like extending from the adapter must be connected to a permanent ground such as a properly grounded outlet box cover. Whenever the adapter is used, it must be held in place by a metal screw. Grounding adapters are not approved for use in Canada.

Replace the plug if the grounding pin is damaged or broken.

The Green (or Green/Yellow) wire in the cord is the grounding wire. When replacing a plug, this wire must be attached to the grounding pin only.

Extension cords connected to this machine should be 12 gauge, three-wire cords with three-prong plugs and outlets. DO NOT use extension cords more than 50 feet (15 m) long.

PLEASE NOTE: FOR NORTH AMERICA ONLY

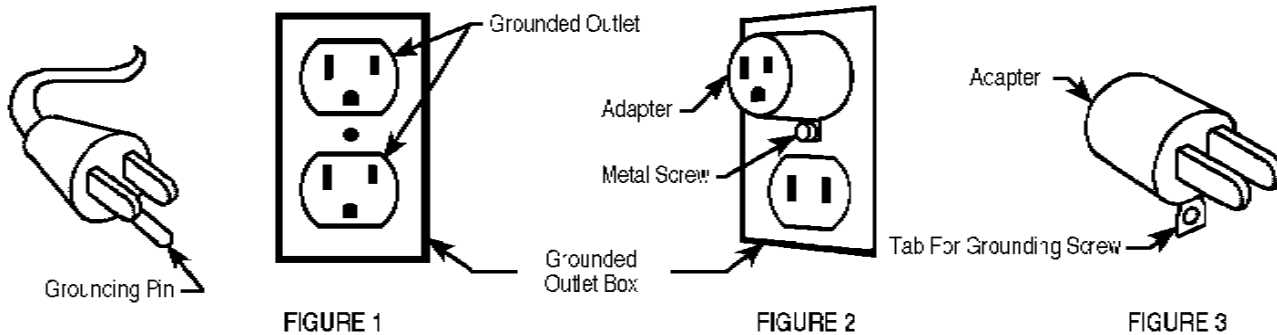

INSTRUCTIONS VISANT LA MISE À LA TERRE (120VAC)

Cet appareil doit être mis à la terre. En cas de défaillance ou de panne éventuelles, la mise à la terre fournit au courant un chemin de moindre résistance qui réduit le risque de choc électrique. Cet appareil est pourvu d'un cordon muni d'un conducteur de terre et d'une fiche avec broche de terre. La fiche doit être branchée dans une prise appropriée correctement installée et mise à la terre conformément aux règlements et ordonnances municipaux.

⚠ AVERTISSEMENT!

Un conducteur de terre mal raccordé peut entraîner un risque de choc électrique. Consulter un électricien ou un technicien d'entretien qualifié si vous n'êtes pas certain que la prise est correctement mise à la terre. Ne pas modifier la fiche fournie avec l'appareil - si elle ne peut être insérée dans la prise, faire installer une prise adéquate par un électricien qualifié.

Cet appareil est destiné à un circuit de 120 V et est muni d'une fiche de terre semblable à celle illustrée par le croquis 1. Un adaptateur temporaire semblable à celui illustré par le croquis 2 et C peut être utilisé pour brancher cette fiche à une prise bipolaire comme l'illustre le croquis 2 si une prise avec mise à la terre n'est pas disponible. L'adaptateur temporaire devrait être utilisé seulement jusqu'à ce qu'une prise avec mise à la terre soit installée par un électricien qualifié. L'oreille rigide ou le crochet ou autre dispositif semblable, de couleur verte, prolongeant l'adaptateur doit être raccordé à un élément correctement mis à la terre comme le couvercle d'une boîte de sortie mise à la terre. L'adaptateur doit être fixé par une vis métallique. Note: Au Canada, l'utilisation d'un adaptateur temporaire n'est pas autorisée par le Code canadien de l'électricité.

Remplacez la prise si la prise de terre est abîmée ou cassée.

Le fil Vert (ou Vert/Jaune) dans la gaine est le fil de terre. Lors du remplacement d'une prise, ce fil doit être raccordé à la prise de terre uniquement.

Les rallonges connectées à cette machine doivent avoir 12 mesures, trois ganses de fil ayant trois fiches masculines féminines tree-prong plugs and outlets. N'UTILISEZ PAS de rallonge de plus de 15 m (50 pieds) de long.

VEUILLEZ NOTER: CES INSTRUCTIONS CONCERNENT UNIQUEMENT L'AMÉRIQUE DU NORD

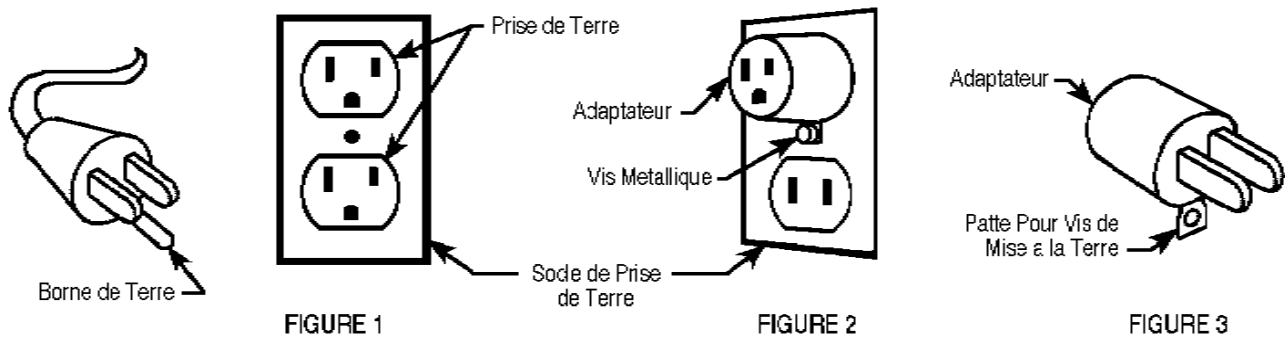

INTRODUCTION

This manual will help you get the most from your Advance™ Reel Cleaner™. Read it thoroughly before operating the machine.

Note: Bold numbers in parentheses indicate an item illustrated on page 5.

This product is intended for commercial use only.

PARTS AND SERVICE

Repairs, when required, should be performed by Advance service personnel using Advance original replacement parts and accessories.

Call Advance for repair parts or service. Please specify the Model and Serial Number when discussing your machine.

NAME PLATE

The Model and Serial Number of your machine are shown on the Nameplate on the machine. This information is needed when ordering repair parts for the machine. Use the space below to note the Model and Serial Number of your machine for future reference.

MODEL NUMBER

SERIAL NUMBER

UNCRATING

When the machine is delivered, carefully inspect the shipping carton and the machine for damage. If damage is evident, save the shipping carton so that it can be inspected. Contact the Advance Customer Service Department immediately to file a freight damage claim.

DO NOT OPERATE MACHINE UNTIL YOU HAVE READ THIS SECTION IMPROPER USE WILL VOID THE WARRANTY

- * Always use a defoamer when foaming occurs to prevent vacuum motor damage.
- * To keep fitting and lines from damage during freezing conditions, use windshield solvent in the pump or keep equipment inside heated areas.
- * Do not let pump run dry.
- * Use approved chemicals only(ph must be between 6 and 9). All chemicals should be added through the feed system, NOT in the tank.
- * All extension cords must have a rating of at least 12/3 (#12 cord). Extension cords should be no longer than 50 feet. Replace the plug immediately if the ground prong becomes damaged or is broken off.
- * DO NOT use water in excess of 140 degrees Fahrenheit.

KNOW YOUR MACHINE

- | | | | |
|----|--------------------------|----|----------------------------------|
| 1 | Operator Handle | 14 | Blow-Dry Hose |
| 2 | Solution Tank Lid | 15 | Recovery Hose Inlet |
| 3 | Accessories | 16 | Solution Fill Hose |
| 4 | Recovery Tank Lid | 17 | Chemical Feed Lines |
| 5 | Recovery Hose | 18 | Switch Plate |
| 6 | Spray Hose | 19 | Power Cord |
| 7 | Spray Gun | 20 | Chemical Container Holders |
| 7A | Nozzle Body | 21 | Operator Handle Adjustment Knobs |
| 8 | Recovery Tank Drain Hose | | |
| 9 | Quick Disconnect | | |
| 10 | Front Castor | | |
| 11 | Blow-Dry Connector | | |
| 12 | Solution Filter | | |
| 13 | Rear Wheel | | |

SWITCH PLATE

- | | |
|---|-----------------|
| A | Solution Switch |
| B | Vacuum Switch |
| C | Chemical Valve |

KNOW YOUR MACHINE

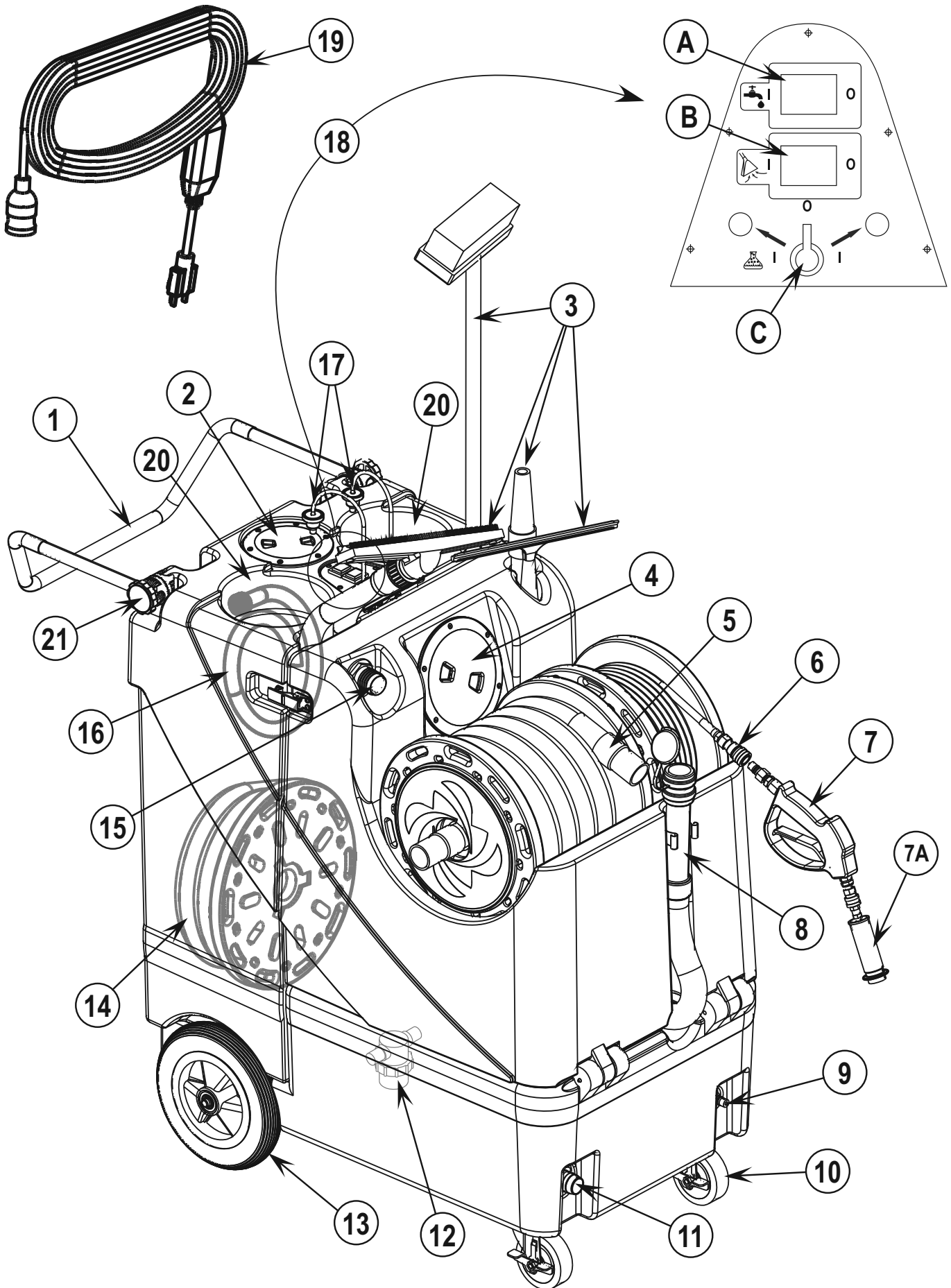

KNOW YOUR MACHINE DESCRIPTIONS

Operator Handle (1) – Operator holds onto this handle to move the machine from one location to another.

Solution Tank Lid (2) – Fill Solution Tank Here. DO NOT add chemicals to Solution Tank, only clean, warm water.

Accessories (3) – Various accessories can be stored on the machine.

Recovery Tank Lid (4) – The Recovery Tank can be flushed out by running clean warm water into this opening with the Recovery Tank Drain Hose open. The Vacuum Float Shut-OFF can also be accessed through this opening for maintenance.

Recovery Hose (5) – Waste water is picked up through this hose.

Spray Hose (6) – 300PSI hose for using spray attachments such as the Spray Gun (7). Connects to the Quick Disconnect (9).

Spray Gun (7) – High / Low pressure spraying attachment, connects to Spray Hose (6). Pull OUT on nozzle body (7A) for LOW pressure. Push IN on nozzle body (7A) for high pressure. Turn nozzle body (7A) counter-clockwise for narrow spray pattern. Turn nozzle body (7A) clockwise for wide spray pattern.

Recovery Tank Drain Hose (8) - Used to empty the recovery tank. NOTE: Hold the end of the hose above the water level in the tank to avoid sudden, uncontrolled flow of waste water when removing plug.

Quick Disconnect (9) – Point of attachment for the Spray Hose (6).

Front Castor (10) – Pivoting castors for steering unit while moving from one location to another. Each castor also has a parking brake lever to prevent unit from rolling.

Blow-Dry Connector (11) – Connect Hose (14) to this connector to use the vacuum motor exhaust for blow drying wet floors. Turn ON vac motor (B) after connecting hose.

Solution Filter (12) – Inline solution filter prevents contaminants from entering the pump.

Rear Wheel (13) – Rear Wheel of unit.

Blow-Dry Hose (14) – Connect this hose to Connector (11) to use the vacuum motor exhaust for blow drying wet floors. Turn ON vac motor (B) after connecting hose.

Recovery Hose Inlet (15) – Point of attachment for the Recovery Hose (5). Waste water enters the Recovery Tank through this opening.

Solution Fill Hose (16) – This hose is tethered to the Solution Tank Lid for the purpose of filling the solution tank in the event you do not already have a hose at the faucet you are using. It is a standard garden hose female fitting. An adaptor is included with this hose for the purpose of connecting to inside or outside thread faucet aerators.

Chemical Feed Lines (17) – These tubes are used to connect cleaning chemical containers to the machine. Metering Tips for changing the chemical to water ratio are installed here.

Switch Plate (18) – The machine's electronic controls are found here.

Power Cord (19) – This is the machine's main power cord, it connects at the right lower rear corner of the machine. It can be wrapped around the Operator Handle (1) when not in use.

Chemical Container Holders (20) – Bottle Holders for standard 1 gallon plastic chemical jugs.

Operator Handle Adjustment Knobs (21) – The Operator Handle (1) can be adjusted up or down by loosening these knobs, moving the handle into the desired position and then re-tightening.

SWITCH PLATE DESCRIPTIONS

Solution Switch (A) – This switch turns ON the solution pump.

Vacuum Switch (B) – This switch turns ON the vacuum motor.

Chemical Valve (C) – This valve switches between chemical containers. When the valve is positioned straight up, it is closed. The valve must be lined up with the ON symbol to draw chemical (see Know Your Machine illustration).

OPERATION

1 Fill the Reel Cleaner with warm water (2) and install containers of chemical (20). Ensure the proper metering tips are inserted in the Chemical Feed Lines (17).

Color	Size	Flow Rate (chemical / water)
Red Purple	.007	½ oz / gallon
Light Purple	.009	1 oz / gallon
Purple	.014	2 oz / gallon
Yellow	.020	4 oz / gallon

2 Push the Reel Cleaner to the area to be cleaned, apply brake (10) and plug in the machine.

3 Prepare area for cleaning by emptying waste receptacles, clearing debris, removing paper products, blowing out vents and sweeping floors.

4 Unreel spray hose (6), connect to front of machine (9), turn on pump switch (A) and turn chemical selector (C) toward the desired chemical.

5 Bring hose to the farthest area from the door to be cleaned. With spray gun (7) in low-pressure setting, apply chemical from bottom up to walls and fixtures. Working out of the area, spray floor as finishing.

6 Allow proper chemical dwell time, according to manufacturer's directions.

7 Agitate heavily soiled areas with scrub brush.

8 Set spray to high pressure and turn chemical selector (C) OFF for rinsing area from top to bottom.

9 Unreel vacuum hose (5), attach wand and floor squeegee (3), and turn on vacuum switch (B).

10 Working way into area, vacuum liquid off the floor.

11 Blow dry (11 & 14) fixtures and squeegee mirrors, if applicable.

12 Drain machine (8) into slop sink or commode.

BALL FLOAT VAC SHUTOFF

When the recovery tank is full, the float system will shut off the incoming air flow and prevent water from entering the vacuum motor. The float may not work properly if the float filter is clogged or if there is heavy foam in the tank.



CAUTION!

To avoid vacuum motor damage, always make sure the float filter is clean and the ball travels freely before turning on the machine and use a defoamer whenever foam is present.

MAINTENANCE AND USE:

- 1 Use only approved chemicals at the recommended mix ratios. All chemicals should be added through the feed system (17) and not added directly to the tank solution. Possible damage to pump, seals or other components could result.
- 2 For optimum performance, flush the Chemical Feed Lines (17) by replacing the chemical container with a container of clear water and spraying until the stream runs clear. See Maintenance Schedule below.
- 3 Pump seals may need to be replaced at 1,000 hours of use or if the pump begins to leak. The pressure regulator valve will need to be rebuilt when a drop in spraying pressure is apparent.
- 4 Prior to each job, inspect, and clean if needed, the Solution Filter (12). Check the recovery tank float filter (4) for debris prior to each job.
- 5 Fill the Solution Tank (2) with clean water. Using warm water is a benefit in cleaning effectiveness, but do not run hot water (140 degrees or more) through the pump.
- 6 Plug in the Power Cord (19). Attach the priming hose to the outlet Quick Disconnect (9). Place the open end of the priming hose into the Recovery Tank, and turn the pump on (A). Run until the pump is fully primed (no visible air in the water flow). Turn the pump off (A) and attach the Spray Hose (6).
- 7 Place chemical in the holder and insert one of the Feed Lines (17) into the container. Secure it by screwing on the cap. The chemical will feed when the Chemical Valve (C) is in the desired position (left or right) and the Spray Gun (7) is used in the low pressure setting (forward = low; back = high).
- 8 Set the Spray Gun (7) to low pressure. Turn the pump on (A) and spray through the tool for a few seconds to fill the line with solution.
- 9 Begin cleaning.

MAINTENANCE SCHEDULE

MAINTENANCE ITEM	Daily	Weekly	Monthly	Yearly
Flush Chemical Lines (17)	X			
Check / Clean Vacuum Float Shutoff	X			
Clean Solution Filter (12)		X		
Lubrication			X	
Check Vacuum Motor Airways			X	
Check Carbon Brush Wear on the Vacuum Motor				X

Have Nilfisk-Advance check the carbon motor brushes once a year or after 500 operating hours.



IMPORTANT!

Motor damage from failure to service the carbon brushes is not covered under warranty.

TECHNICAL SPECIFICATIONS

Vacuum Motor	3 stage, 12 amp, 1400 watt, 110v/60Hz
Water lift	117" (297 cm.)
Air Flow	100 cfm (2832 l./min.)
Tank Construction	Rotational Molded Polyethylene
Solution Tank Capacity	25 gallon (11.3 l.)
Recovery Tank Capacity	22 gallon (10 l.)
Application Flow	300 psi @ nozzle, 1 gpm
Solution Hose Length	50 feet (15.25 m.)
Recovery Hose Length	25 feet with 1.5" diameter (15.25m. X 3.8 cm)
Blower Hose	13 feet (4 m.)
Power Cord	50 feet safety yellow w/GFCI (15.25 m.)
Rear Wheels	2 - 10" (25 cm.)
Front Casters	2 - 4" w/ brake (10 cm.)
Height	40" (101 cm.)
Length	36" (91 cm.)
Width	21" (53.3 cm.)
Machine Weight	135 lbs (61.2 kg)
Shipping Weight	180 lbs (81.6 kg)



9435 Winnetka Ave North
Minneapolis, MN 55445
www.advance-us.com
Phone: 800-989-2235
Fax: 800-989-6566
©2017 Nilfisk, Inc.

