

AquaMAX™

AX 650

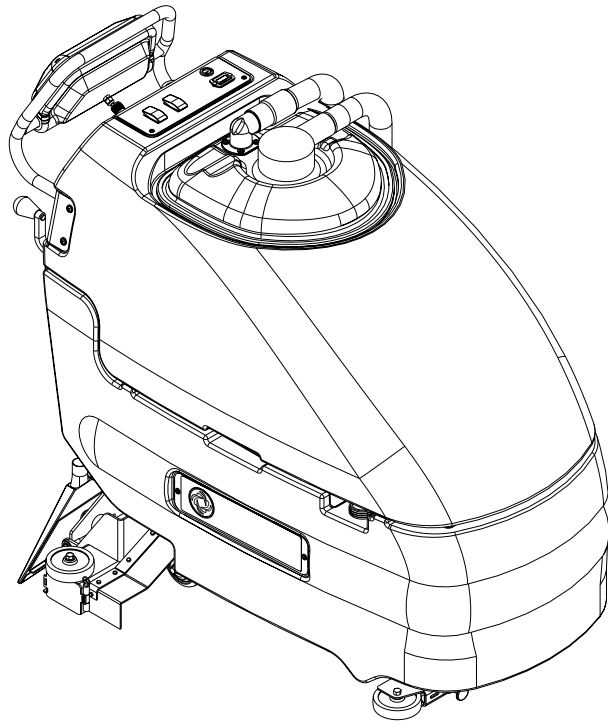

SERVICE MANUAL
Advance MODEL 56212000
Nilfisk MODEL 56212260



Nilfisk
Advance
setting standards

1/02 revised 6/03 Form Number 56043069

TABLE OF CONTENTS

GENERAL INFORMATION	2
SAFETY INSTRUCTIONS	3
SPECIFICATIONS & MAINTENANCE	4-6
PM CHECKLIST	7
KNOW YOUR MACHINE	9-12
SOLUTION SYSTEM	13-19
FUNCTIONAL OVERVIEW	13
PUMP CIRCUIT SWITCH FUNCTIONAL OVERVIEW	14
BASIC TROUBLESHOOTING	15
TROUBLESHOOTING GUIDE ELECTRICAL	15-17
MAJOR COMPONENTS SPECIFICATIONS	18
NOZZLE MAINTENANCE	18
NOZZLE FIXTURE INSTALLATION	18
SOLUTION PUMP REMOVAL	18
SCRUB BRUSH SYSTEM	20-24
GENERAL BRUSH SYSTEM OVERVIEW	20
SCRUB BRUSH MOTOR RUN FUNCTION	20
TROUBLESHOOTING GUIDE ELECTRICAL	21-22
SCRUB BRUSH MOTOR REMOVAL	23
SCRUB BRUSH ASSEMBLY REPLACEMENT	23
RECOVERY SYSTEM	25-34
FUNCTIONAL OVERVIEW	25
VACUUM SWITCH CIRCUIT OVERVIEW	26
VACUUM / RECOVERY SYSTEM SERVICE MAINTENANCE CHECKLIST	27
TROUBLESHOOTING GUIDE	27
TROUBLESHOOTING GUIDE ELECTRICAL	28-30
VACUUM MOTOR REMOVAL	31
RECOVERY BLADDER REMOVAL	32
RECOVERY BLADDER INSTALLATION	32
REMOVAL OF THE UPPER SOLUTION/RECOVERY TANK ASSEMBLY	32
WHEEL DRIVE SYSTEM	35-44
GENERAL FUNCTIONAL OVERVIEW	35
WHEEL DRIVE TROUBLESHOOTING GUIDE	36
TROUBLESHOOTING GUIDE ELECTRICAL	37-38
CHAIN MAINTENANCE	39
CHAIN REMOVAL & ADJUSTMENT	39
WHEEL DRIVE MOTOR REMOVAL	39
DRIVE WHEEL REMOVAL	39
5K POTENTIOMETER TESTING & REMOVAL	41
5K POTENTIOMETER INSTALLATION & ADJUSTMENT	42
25K WHEEL DRIVE SPEED LIMIT POTENTIOMETER TESTING	43
DIRECTION SWITCH S6 INSTALLATION & ADJUSTMENT	44
ELECTRICAL SYSTEM	45-51
BATTERIES / CHARGERS	45
DESCRIPTION OF THE BATTERY LOW VOLTAGE CUTOUT FEATURE	46
LOW VOLTAGE CUTOUT MODULE FUNCTION	46
DESCRIPTION OF THE BATTERY FUEL GAUGE	46
CHARGING THE BATTERIES	46
BATTERY MAINTENANCE / TESTING	47
REMOVAL OF ELECTRICAL PANEL LOWER CHASSIS	48
ELECTRICAL COMPONENT LOCATION	49
WIRING SCHEMATIC	50
WIRING DIAGRAM	51

Note: All references to right, left, front, or rear in this manual are as seen from the operator's stand-point.

GENERAL INFORMATION

INTRODUCTION

This manual will help you get the most from your **AquaMAX™ / AX 650**. Read it thoroughly before servicing the machine.

Note: Bold numbers in parentheses indicate an item illustrated on pages 9-10.

This product is intended for commercial use only.

PARTS AND SERVICE

Repairs, when required, should be performed by your Authorized Nilfisk-Advance Service Center, who employs factory trained service personnel, and maintains an inventory of Nilfisk-Advance original replacement parts and accessories.

Call the NILFISK-ADVANCE DEALER named below for repair parts or service. Please specify the Model and Serial Number when discussing your machine.

(Dealer, affix service sticker here.)

NAME PLATE

The Model Number and Serial Number of your machine are shown on the Nameplate on the machine. This information is needed when ordering repair parts for the machine. Use the space below to note the Model Number and Serial Number of your machine for future reference.

MODEL NUMBER _____

SERIAL NUMBER _____

TRANSPORTING THE MACHINE

CAUTION!

Before transporting the machine on an open truck or trailer, make sure that . . .

- The machine is tied down securely - see tie-down location **(28)**.
- All access doors and covers are secured.
- Tape and strap the Recovery Tank Dome Lid **(2)** to prevent any movement.
- Check to see that the Upper Tank Latch **(13)** is secured.

TOWING

CAUTION!

If the machine must be towed or pushed, make sure the Key Switch (Main Power) **(4)** is in the OFF position, disconnect wheel drive motor wiring harness and do not move the machine faster than a normal walking pace (2-3 mph, 3-5kph) and for short distances only.

OTHER MANUALS AVAILABLE FOR THE AQUAMAX™ / AX 650

The following manuals are available from the Nilfisk-Advance Literature Service Department (order according to machine's model number and serial number:

- A Parts List and Operation Manual are available for each machine.
- Operation Manuals for the AquaMAX™ / AX 650 are multi-language; (Danish, Norwegian, Swedish & Finnish), (English, German, French & Netherlands) or (Spanish, Portuguese, Italian & Greek).

CAUTIONS AND WARNINGS

SYMBOLS

Nilfisk-Advance uses the symbols below to signal potentially dangerous conditions. Always read this information carefully and take the necessary steps to protect personnel and property.

DANGER!

Is used to warn of immediate hazards that will cause severe personal injury or death.

WARNING!

Is used to call attention to a situation that could cause severe personal injury.

CAUTION!

Is used to call attention to a situation that could cause minor personal injury or damage to the machine or other property.

GENERAL SAFETY INSTRUCTIONS

Specific Cautions and Warnings are included to warn you of potential danger of machine damage or bodily harm.

WARNING!

- This machine shall be used only by properly trained and authorized persons.
- Keep sparks, flame and smoking materials away from batteries. Explosive gases are vented during normal operation.
- Charging the batteries produces highly explosive hydrogen gas. Charge batteries only in well-ventilated areas, away from open flame. Do not smoke while charging the batteries.
- Remove all jewelry when working near electrical components.
- Turn the key switch off (O) and disconnect the batteries before servicing electrical components.
- Never work under a machine without safety blocks or stands to support the machine.
- Do not dispense flammable cleaning agents, operate the machine on or near these agents, or operate in areas where flammable liquids exist.
- Do not clean this machine with a pressure washer.
- Do not operate this machine on ramps or inclines of more than a 2 percent gradient.

CAUTION!

- This machine is not approved for use on public paths or roads.
- This machine is not suitable for picking up hazardous dust.
- When operating this machine, ensure that third parties, particularly children, are not endangered.
- Before performing any service function, carefully read all instructions pertaining to that function.
- Do not leave the machine unattended without first turning the key switch off (O), removing the key and securing the machine.
- Turn the key switch off (O) before changing the brush, and before opening any access panels.
- Take precautions to prevent hair, jewelry, or loose clothing from becoming caught in moving parts.
- Use caution when moving this machine in below freezing temperature conditions. Any water in the solution or recovery tanks or in the hose lines could freeze.
- The batteries must be removed from the machine before the machine is scrapped. The disposal of the batteries should be safely done in accordance with your local environmental regulations.

SAVE THESE INSTRUCTIONS

SPECIFICATIONS

General Specifications

English (Metric)

Machine Length	55 in. (140cm)
Machine Width (minimum)	28.25 in. (72 cm)
Machine Height	43.25 in. (110 cm)
Machine Net Weight*	430 lbs. (195 kg)
Machine Gross Weight**	1,171 lbs. (531 kg)
Cleaning Width (scrubbing path)	24.5 in. (62 cm)
Coverage Rate Per Hour (Restoration mode)	7,200 sq. ft. (669 m ²)/ hour (max)
Coverage Rate Per Hour (Maintenance mode)	13,200 sq. ft. (1226 m ²)/ hour (max)
Brush Cylindrical	3.16 in. (8 cm) Dia. x 24.5 in. (62 cm) length
Brush Speed (no load)	1200 RPM
Solution Tank Capacity	40 gal. (151 l)
Recovery Tank Capacity	31 gal. (117 l)
Vacuum Water Lift	72 inches (sealed) 30 inches (1 in. orifice)
Ramp Climbing Ability (gradeability)	Max. 24.4% grade (13.7 degrees)
Sound Level	77.7 dB(A)/20uPa (at operator)
Maximum Transport Speed	290 fpm (88 m/m)
Restoration Mode Speed	20 ft (6 m) in 20 sec.
Maintenance Mode Speed	20 ft (6 m) in 11 sec.
Minimum Aisle Turning Width	55 inches (140 cm)
Power Source 36VDC Battery Pack	Qty (6) 6V, 238 AH batteries
Battery Weight (each)	66 lbs. (30 kg)
Battery Compartment Size***	
Height	12.5 in. (31.7 cm)***
Width	21.5 in. (54.6 cm)***
Length	25.5 in. (64.8 cm)***
Battery Chargers	36V Auto 20 Amp (120Vac, 60 Hz)
Wheel Drive Motor	36V, 1/2 hp, (320 RPM) 9-25A
Brush Motor	36V, 1/2 hp (1800 RPM) 12A
Vacuum Motor (2) (configuration parallel)	36V, (7/8 hp each) (35A both)
Total Rate Machine Current	58A****

***Net Weight:** Standard machine without options, empty solution and recovery tanks, without removable scrub brush and no batteries installed.

****Gross Weight:** Standard machine without options, full solution tank and empty recovery tank, with removable scrub brush and maximum size battery.

***Note: Battery box is not rectangular. See top view in Electrical System section.

****Average current draw under normal working loads.

SPECIFICATIONS

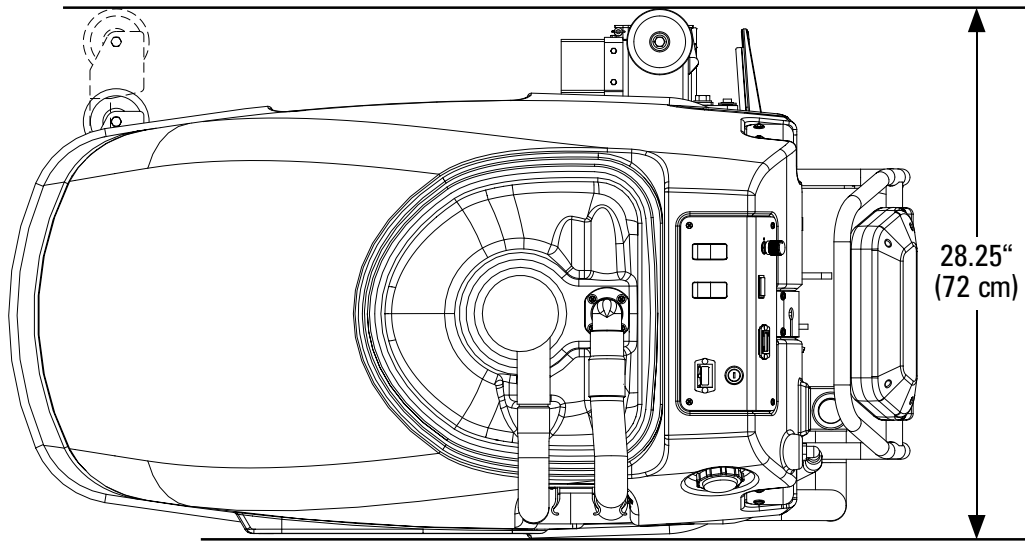

TOP VIEW

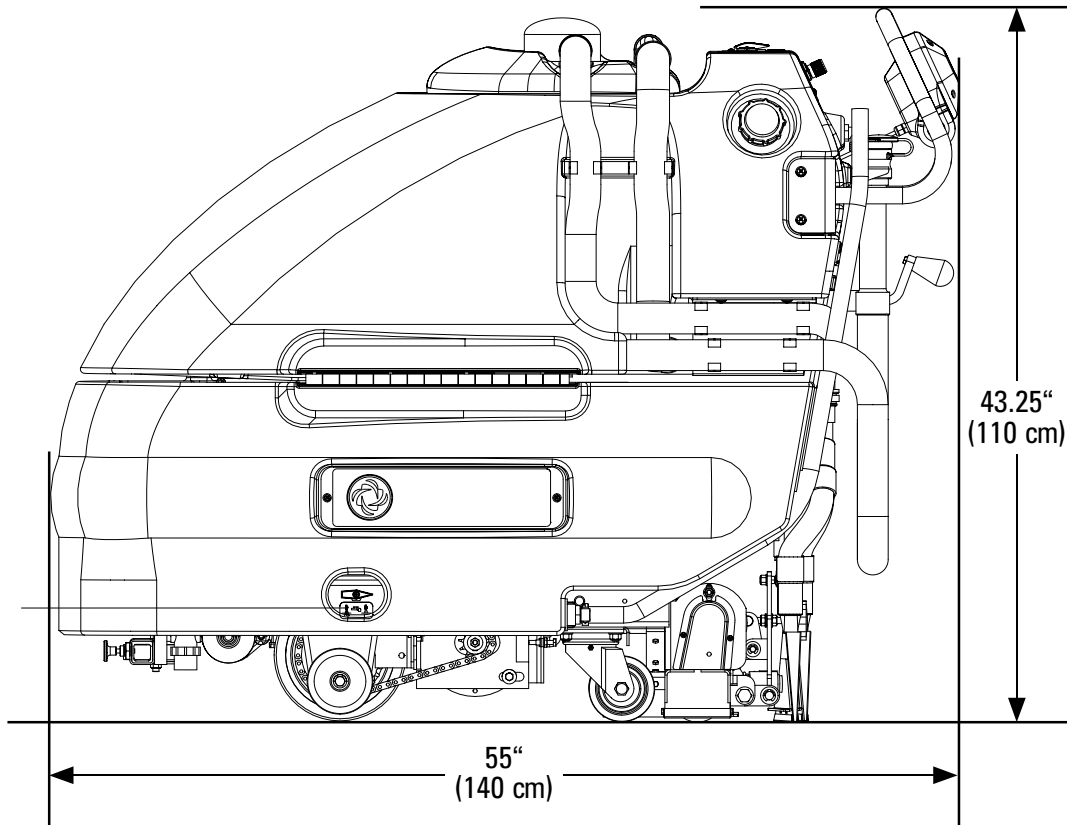

SIDE VIEW

MAINTENANCE

AFTER USING THE MACHINE

- 1 Raise the Brush Deck (12).
- 2 Turn the Master Key Switch (4) OFF.
- 3 To empty the solution tank, pull the Solution Drain Hose (21) off the elbow. Direct the hose to a designated waste water "DISPOSAL SITE" and remove the plug. Rinse the tank with clean water. Inspect the solution hoses; replace if kinked or damaged.
- 4 To empty the recovery tank, take the Recovery Drain Hose (17) off its hanger. Direct the hose to a designated waste water "DISPOSAL SITE" and remove the plug (hold the end of the hose above the water level in the tank to avoid sudden, uncontrolled flow of waste water). Rinse the tank with clean water. Inspect the recovery and vacuum hoses; replace if kinked or damaged.
- 5 Remove the Brush (29), rinse with warm water and remove any built-up string, hair or carpet fibers.
- 6 Disconnect the Recovery Hose (24) from the Recovery Tank Dome Lid (2) and flush with warm water to wash any debris out of the Recovery Hose / Pick-Up Tool Assembly. **NOTE:** Make sure that you have disconnected the correct hose, if you run water into the vac motors they will be damaged.
- 7 Wipe the machine with a damp cloth. Do not use abrasive chemicals or solvents.
- 8 Perform any required maintenance before storage.

MAINTENANCE SCHEDULE

Maintenance intervals given are for average operating conditions. Machines used in severe operational environments may require service more often.

MAINTENANCE ITEM	Daily	Weekly	Monthly	Yearly
Charge Batteries	•			
Check / Clean Power Brush	•			
Check / Clean Tanks & Hoses	•			
Check / Clean Vacuum Shut-Off Float	•			
Check / Clean Vacuum Motor Filters	•			
Clean Pick-Up Tools	•			
Clean Spray Nozzles		•		
Check Each Battery Cell(s) Water Level		•		
Inspect Brush Deck Skirt		•		
Inspect & Clean InLine Pump Filter		•		
Lubricate the Machine			•	
* Check Carbon Brushes				•

Note: See the individual machine system sections for maintenance information.

* Have Nilfisk-Advance Authorized Dealer:

Check vacuum motor carbon brushes (Qty 2) once a year or after 300 operating hours.

Check brush motor carbon brushes (Qty 4) once a year or after 500 operating hours.

Note if the vacuum or brush motor brushes are 9.5mm (3/8 inches) or shorter, replace them.

Check wheel drive motor carbon brushes every 500 operating hours. The original length of each brush is 25mm (1 inch). Replace when shorter than 9.5 mm (3/8 inches) to obtain the same motor efficiency as a new brush.

- 9 Store the machine in a clean, dry place with the tank dome lid open.

WARNING!

Turn the key switch off and disconnect the batteries before servicing the machine.

BATTERIES AND CHARGERS

Attention: See the Electrical System manual section for battery installation and charger system requirements.

LUBRICATING THE MACHINE

Once a month, pump a small amount of grease into each grease fitting on the machine until grease seeps out around the bearings. Wipe off the grease fittings to avoid excessive grease which could fall from the machine and soil the carpet.

Grease fitting locations are:

- Rear Caster Wheel Swivels (2)

Once a month, apply light machine oil to lubricate the:

- Drive Wheel Motor Chain
- General Pivot Points For the Brush Housing Linkage

Advance AquaMAX™ Model # 56212000
Nilfisk AX 650 Model # 56212260
PM Checklist

Customer _____
Address _____
City _____ **St** _____ **Zip** _____
Model _____ **Serial** _____ **Hours** _____

Defect Codes
A needs adjustment
B binding
C dirty or contaminated
D damaged, bent or torn
L leaks
M missing
W worn out

Ref	OPERATIONAL INSPECTION ITEMS	OK	Defect Codes (circle)	Does Not Work
1	Drive Paddle Operation (check for Fwd/Rev drive & any neutral creep)		A B D	
2	Wheel Drive Performance (test for variable drive speeds Min/Max)		Noisy — Sluggish	
3	Scrub System (raise/lower brush housing/vacuum shoes & test auto brush functions)		A B W	
4	Scrub Brush Pressure (load meter setting middle of green zone 8-15 Amps)		A B	
5	Vacuum Performance (Sealed water lift 69" and 1- inch open hole adapter 28 inches)		C L W	
6	Vacuum System Auto Shut Off (lift the scrub/vac shoe lever to test, 10 sec time delay)			
7	Solution Controls and Pump (on/off/auto functions and flow volume Min/Max)		C D L	
8	Solution Spray Nozzles Outputs (for both maintenance/restoration modes)		C L W	
9	Solution Accessory Port Output (test by connecting an accessory tool)		C L W	

Ref	VISUAL INSPECTION ITEMS	Comments	OK	Defect Codes (circle)	Does Not Work
10	Dome Lid Cover & Gasket			C D L	
11	Vacuum Float Ball & Cage Assembly	clean float		C D M	
12	Recovery Tank Bladder	Drain & flush		C D L	
13	Vacuum motor Hose (from cover to motor housing)			C D L	
14	Vacuum Pickup Shoe Hoses (1-long & 2 short)	Back flush		C D L	
15	Brush Housing Retainer Knob (storage/extension to right)			B D W	
16	Scrub Deck Splash Skirts & Guide Wheels			D M	
17	Solution Solenoid Valve			D L W	
18	Scrub Brush Bristles & Drive Belt Wear (check belt tension)	remove brush & guard		A D W	
19	Solution Delivery Control Valve			B C L	
20	Solution Tank, Delivery Hoses & Filter	Clean filter screen		C L	
21	Vacuum Motor Gaskets and Filters			C D L	
22	Vacuum Motor Carbon Brushes	Wear limit 3/8"		C W	
23	Battery Pack Condition (load test, clean & water)	check charger also		C W	
24	Recovery Tank Drain Hose & Cap			C D L	
25	Solution Tank Drain Hose			C D L	
26	Caster Wheels	lubricate		C D W	
27	Drive Wheel Motor & Drive Chain	lubricate & tension		A D W	

NOTE: For additional service information see service manual form number 56043069 and operators manual form numbers 56041543, 56041544 & 56041545.

Defect Codes **A** needs adjustment **C** dirty or contaminated **M** missing
B binding **D** damaged, bent or torn **W** worn out
L leaks

WORK COMPLETED BY: _____

ACKNOWLEDGED BY: _____

Service Technician Signature _____

Date _____

Customer Signature _____

Date _____

BLANK PAGE

KNOW YOUR MACHINE

- | | | | |
|----|--------------------------|----|---------------------------------------|
| 1 | Upper (recovery) Tank | 16 | Battery Charger Connector |
| 2 | Recovery Tank Dome Lid | 17 | Recovery Tank Drain Hose |
| 3 | Battery Fuel Gauge | 18 | Pick-Up Tool |
| 4 | Master Key Switch | 19 | Brush Height Adjustment Knob |
| 5 | Pump Switch | 20 | Brush Deck |
| 6 | Vacuum Switch | 21 | Solution Drain Hose / Level Indicator |
| 7 | Hour Meter | 22 | Solution Fill Cap |
| 8 | Brush Pressure Indicator | 23 | Vacuum Hose |
| 9 | Speed Control Knob | 24 | Recovery Hose |
| 10 | Operator Control Handle | 25 | Nozzle Selector Knob |
| 11 | Drive Paddle | 26 | Stabilizer Caster |
| 12 | Brush Deck Lift Lever | 27 | Rear Caster |
| 13 | Upper Tank Latch | 28 | Tie Down Location (2) |
| 14 | Accessory Port | | |
| 15 | Circuit Breakers | | |
| | 6 Amp-Control Circuit | | |
| | 40 Amp-Vac Motors | | |
| | 20 Amp-Brush Motor | | |
| | 20 Amp-Drive Motor | | |

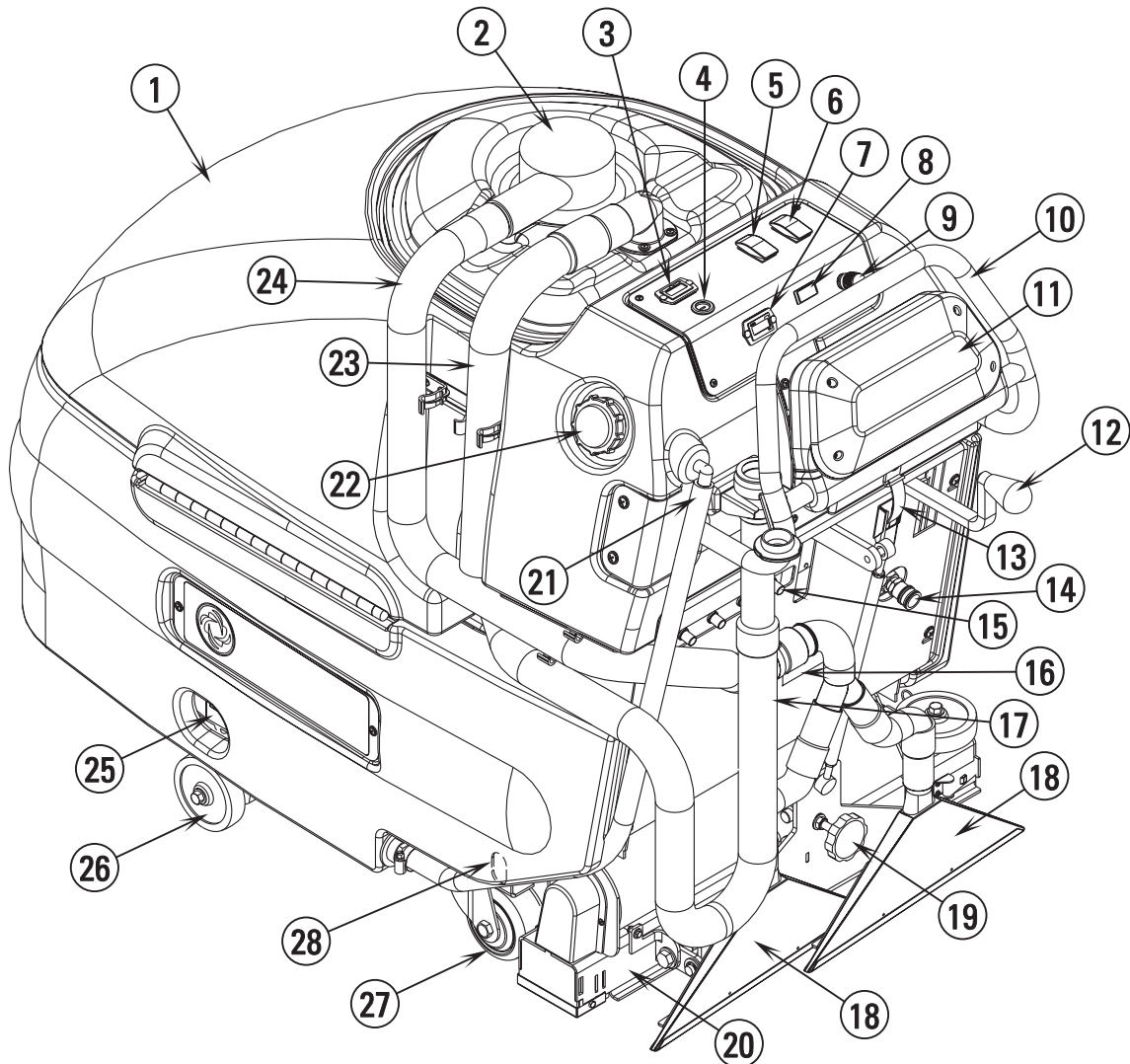

KNOW YOUR MACHINE

- 29 Brush Access Door
- 30 Brush Access Door Latch
- 31 Deck Release Knob
- 32 Vac Motor Filters
- 33 Automatic Float Shut-Off
- 34 Waste Water Bladder
- 35 Lower (solution) Tank Flush-Out Cap
- 36 InLine Pump Filter
- 37 Lower (solution) Tank
- 38 Roller Bumper Release Knob
- 39 Roller Bumper

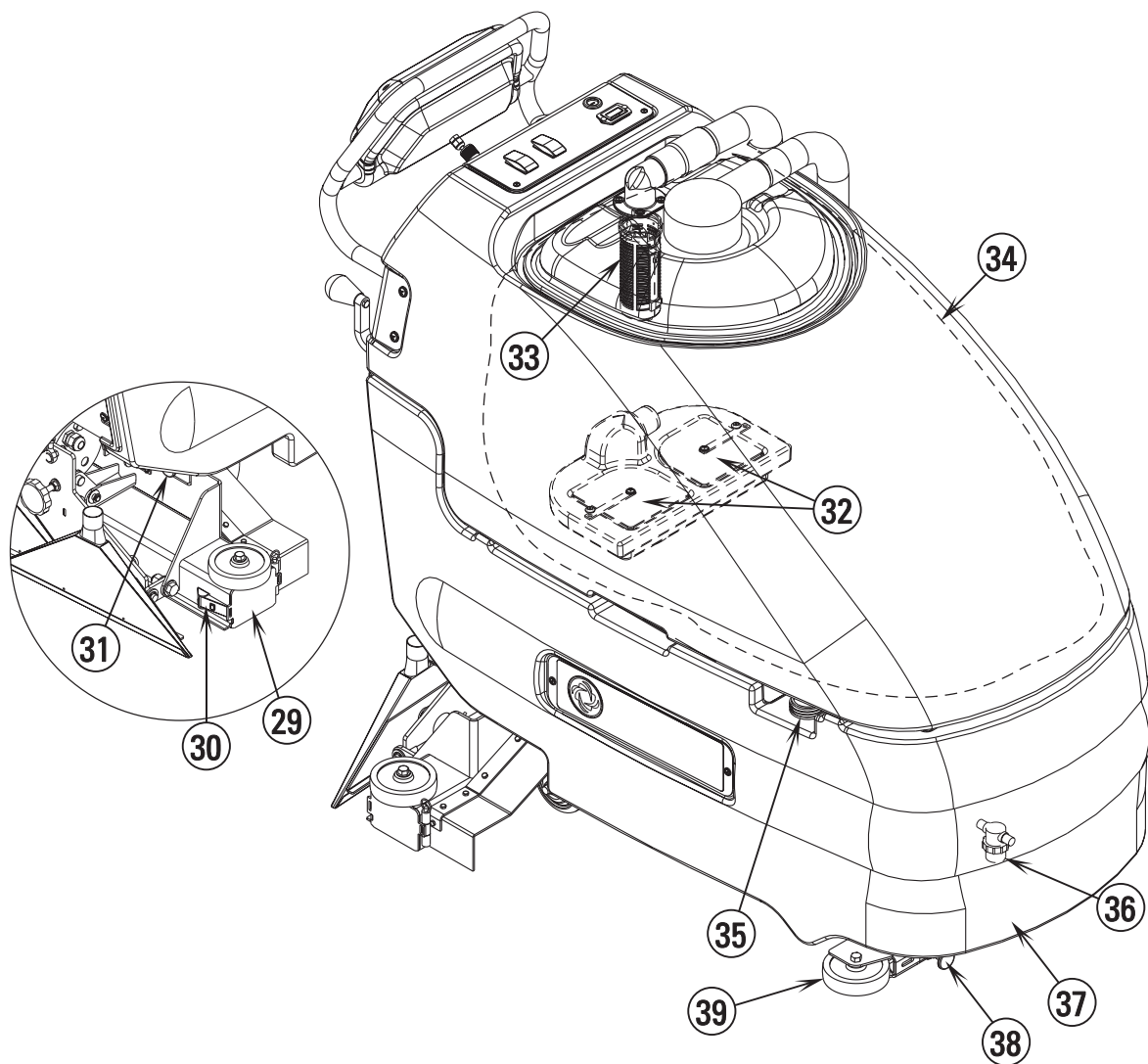

KNOW YOUR MACHINE

FUNCTIONAL DESCRIPTION OF CONTROLS:

Upper (recovery) Tank (1) - Waste water recovered from carpet is deposited here inside of a bladder **(34)**. Area outside of waste water bladder **(34)** is utilized for extra clean solution capacity. The batteries and Vac Motor Filters **(32)** can be accessed by opening this tank to the side.

Recovery Tank Dome Lid (2) - Point of entry for waste water into bladder. Also houses Automatic Float Shut-Off **(33)** which shuts off vacuum port to vac motors when bladder is full. Remove this lid to rinse out the waste water bladder or to fill the solution tank.

Battery Fuel Gauge (3) - Shows current state of charge of batteries. A double-flashing light indicates low batteries, charge immediately. **NOTE:** When the battery fuel gauge shows double-flashing lights, all systems shut down except the wheel drive system.

Master Key Switch (4) - Main power switch.

Pump Switch (5) - This button is used to select the mode of operation for the solution system. There are 3 modes of operation for this system. The modes are AUTO / OFF / ON. Following is a description of each mode.

AUTO MODE: In this mode the solution flow will be turned ON whenever the brush is lowered and the machine is moving forward. The solution flow will be turned off when the machine is not moving, moving in reverse or the brush is raised.

OFF MODE: In this mode the solution flow is turned off.

ON MODE: This mode is for accessory use. The pump is ON at all times as long as the Master Key Switch **(4)** is ON.

Vacuum Switch (6) - This button is used to select the mode of operation for the vacuum system. There are 3 modes of operation for this system. These modes are AUTO / OFF / ON. Following is a description of each mode.

AUTO MODE: In this mode the vacuum will be turned ON whenever the brush is lowered and the Master Key Switch **(4)** is ON. While in this mode the vacuum will remain on for 10 seconds after the brush is raised.

OFF MODE: In this mode the vacuum is off.

ON MODE: This mode is for accessory use. The vacuum is ON at all times as long as the Master Key Switch **(4)** is ON.

Hourmeter (7) - Displays number of hours machine has been used. **NOTE:** The hourmeter only runs when the vac motors are running.

Brush Pressure Indicator (8) - This meter should be reading 8-15 amps (green zone), readings outside this range indicate the need for brush height adjustment.

Speed Control Knob (9) - Turn this knob clockwise to increase maximum speed range and counter-clockwise to decrease maximum speed range.

Operator Control Handle (10) - Operator holds onto this handle to maneuver the machine.

Drive Paddle (11) - The operator can make the machine go forward by pushing forward on it, or reverse by pulling backward on it. The speed is variable depending on how far forward or backward the paddle is moved. The brush and pump will operate when the brush deck is in the "DOWN" position and the drive paddle is engaged in either direction, both will stop 1 second after the drive paddle is released. **NOTE:** The pump does not run when the drive paddle is in the reverse position.

Brush Deck Lift Lever (12) - This lever is used to raise or lower the brush deck. Both pump and vacuum turn ON when the brush deck is lowered and turn OFF when it is raised if their switches are in the AUTO position. **NOTE:** Machine must be moving forward to activate pump, forward or reverse to activate brush. Vacuum system shuts off 10 seconds after raising the brush deck.

Upper Tank Latch (13) - This latch is used to secure the Upper Tank **(1)** to the machine to prevent the tank from opening while operating the machine since the Operator Control Handle **(10)** is mounted to the upper tank.

Accessory Port (14) - This is used to connect external accessories.

Circuit Breakers (15)

6 Amp-Control Circuit - Provides overload protection. If it trips, it will pop out. To reset, wait one minute and press the button back in. If any breaker trips repeatedly, have the machine serviced.

40 Amp-Vac Motors - Provides overload protection to machine's vacuum motors. If it trips, it will pop out. To reset, wait one minute and press the button back in. If any breaker trips repeatedly, have the machine serviced.

20 Amp-Brush Motor - Provides overload protection to machine's brush motor. If it trips, it will pop out. To reset, wait one minute and press the button back in. If any breaker trips repeatedly, have the machine serviced.

20 Amp-Drive Motor - Provides overload protection to machine's wheel drive motor. If it trips, it will pop out. To reset, wait one minute and press the button back in. If any breaker trips repeatedly, have the machine serviced.

Battery Charger Connector (16) - Plug battery charger into this port to charge batteries.

Recovery Tank Drain Hose (17) - Used to empty the recovery tank. **NOTE:** Hold the end of the hose above the water level in the tank to avoid sudden, uncontrolled flow of waste water when removing plug.

Pick-Up Tool (18) - Removes excess solution from carpet after scrubbing.

Brush Height Adjustment Knob (19) - Used to adjust the height of the brush deck. Turn clockwise to raise the brush deck and counter-clockwise to lower the brush deck. **NOTE:** Use this adjustment knob in conjunction with the Brush Pressure Indicator **(8)**.

Brush Deck (20) - Contains brush drive motor and brush.

KNOW YOUR MACHINE

FUNCTIONAL DESCRIPTION OF CONTROLS (CONTINUED)

Solution Drain Hose/Level Indicator (21) - Used to empty the solution tank and show current level of solution in tank, graduations are marked on the side of the machine next to the hose.

Solution Fill Cap (22) - The solution tank can be filled at this location or through the front opening at the top of the Upper Tank after removing the Recovery Tank Dome Lid.

Vacuum Hose (23) - This hose connects to the vac motor assembly in order to create a vacuum inside the waste water bladder.

Recovery Hose (24) - This hose connects between the Pick-Up Tools (18) and the Recovery Tank Dome Lid (2) to bring waste water into the bladder.

Nozzle Selector Knob (25) - Use this knob to select either Maintenance Mode or Restoration Mode. **NOTE:** The Speed Control Knob (9) has two corresponding settings.

Maintenance Mode: Lower solution flow, higher travel speed. Recommended for frequent surface cleaning.

Restoration Mode: Higher solution flow, lower travel speed. Recommended for less frequent deep cleaning.

Stabilizer Caster (26) - This caster provides stability to the unit when opening the Upper (recovery) Tank (1).

Rear Caster (27) - These two casters along with the main drive wheel bear the weight of the machine and allow easy maneuvering around corners.

Tie Down Location (28) - These holes in the chassis give a point to which the machine can be secured to a trailer etc. for purpose of transporting.

Brush Access Door (29) - The power brush can be removed or installed via this door.

Brush Access Door Latch (30) - Unsnap this latch to allow access to the power brush.

Deck Release Knob (31) - Pull this knob out and slide Brush Deck out to the right until it latches in place. This allows cleaning under shelves, railings, etc.

Vac Motor Filters (32) - Intake filters for vacuum motor assembly. Refer to the maintenance chart for maintenance intervals.

Automatic Float Shut-Off (33) - The float shut-off blocks the vacuum port when the Waste Water Bladder (34) is full. You can tell when the float closes by the sudden change in sound of the vacuum motors. When the float closes, the recovery tank must be emptied. The machine will not pickup water with the float closed.

Waste Water Bladder (34) - Contains waste water as it is recovered from carpet. Total capacity of 31 gallons (117 Liters).

Lower (solution) Tank Flush-Out Cap (35) - This cap allows access to the Lower (solution) Tank for the purpose of flushing with clean water.

InLine Pump Filter (36) - This filter removes debris from the solution prior to flowing through the pump. Drain solution prior to cleaning this filter.

Lower (solution) Tank (37) - This tank in combination with the upper tank brings total solution capacity to 40 gallons (151.4 Liters).

Roller Bumper Release Knob (38) - This knob allows you to slide the roller bumper out or in to limit how close the machine travels to the wall.

Roller Bumper (39) - This is a 3 position slide-out bumper to aid in machine maneuvering along walls.

DESCRIPTION OF THE BATTERY FUEL GAUGE

The Battery Fuel Gauge (3) uses a 10 bar LED display that indicates the state of the batteries charge, successively, bar by bar, from full to empty. At 70% depth of discharge a single flashing light signals an energy reserve alert. At 80% of discharge, a double flashing light signals an empty alarm. The battery gauge will retain the last state-of-charge condition even when the machine has been turned off. The battery fuel gauge state-of-charge display indication is automatically reset to full charge when the battery pack is recharged.

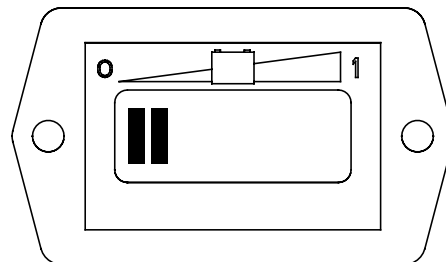

SOLUTION SYSTEM

GENERAL SYSTEM FUNCTIONAL OVERVIEW

Two plastic (polyethylene) molded tanks store the machine's extraction solution. Total machine solution capacity is 40 gallons (151 l). There are two fill locations in the upper dual-purpose solution/recovery tank. The lower tank serves the purpose of machine frame, solution storage and battery compartment.

See Figure 1. Plumbed into the front lower tank bottom is a serviceable solution filter to keep debris from entering the solution pump (M5) and solenoid valve (L1). Also fitted to the rear tank bottom is a clear flexible hose used to drain the tank for maintenance and to indicate the system's fill level. The pump output flow volume is controlled by a two-position mechanical diverter valve (C) connected by hoses to the two separate brush nozzles. Nozzle (A) directs the solution spray pattern onto the scrub brush when the diverter valve knob is placed in the maintenance extraction mode (minimum flow). Nozzle (B) directs the solution spray forward of the scrub brush when the flow diverter knob is placed in the restoration extraction mode (maximum flow).

FIGURE 1

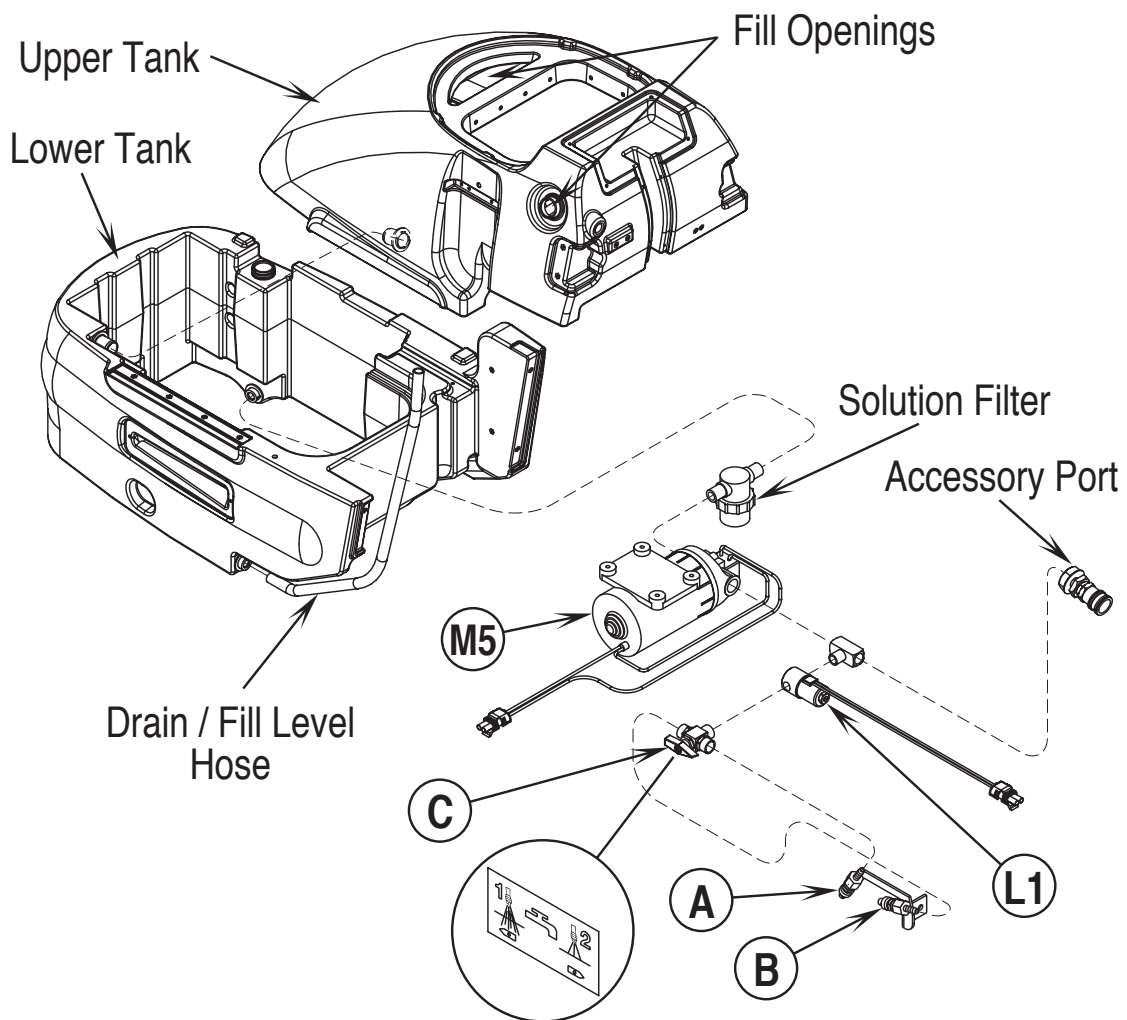

SOLUTION SYSTEM

PUMP CIRCUIT SWITCH FUNCTIONAL OVERVIEW

There are (2) pump switch operation modes ON for stationary optional accessory use and AUTO for machine transport extraction use. Note: See the *Function Description of Controls* section in the Know Your Machine system for a complete explanation of the solution pump switch operator modes.

Pump switch position ON circuit explanation

See Figure 2. With the key switch (S2) closed the VIO wire supplies a 36V (Pos.) input to the pump switch (S4). With the switch in the ON position the contacts 3 & 2 are closed which feeds the pump relay K4, therefore completing the positive side of the control circuit. The negative side of the pump relay coil circuit is completed through the (S4) pump switch contacts 6 & 5. This then energizes (turns on) the high current load contact and the pump motor (M5) runs. Note: The accessory tool connected to the pump outlet must have its control valve lever open to allow the internal pump pressure switch to be closed to make the pump run in the ON position.

FIGURE 2

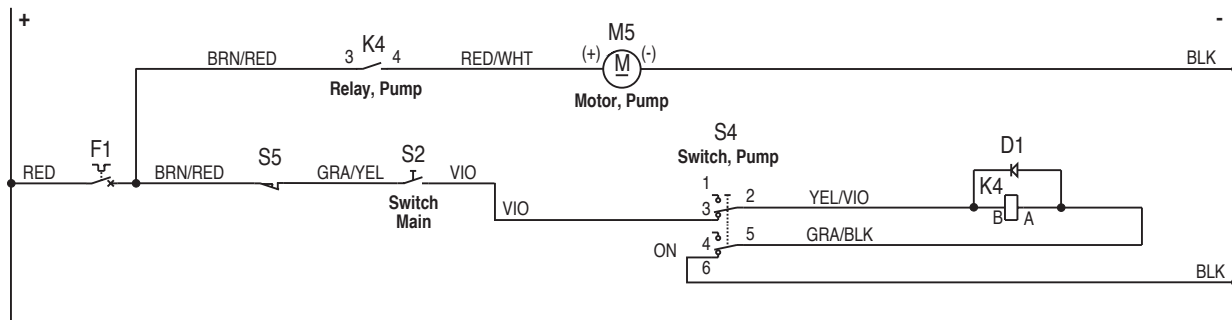

Pump switch position AUTO circuit explanation

See Figure 3. With the key switch (S2) closed the VIO wire supplies the 36V (Pos.) input to the low voltage relay module (K5). The module circuit is closed when the battery pack voltage is higher than 31.5 volts (see **Note 1**). The Yel output wire then supplies the positive circuit voltage feed through the closed (S1) brush switch, which is closed by the operator lowering the brush raise/lower lever. The output voltage signal from (S1) Grn/Blu wire supplies the input to the L1 solenoid and S4 pump switch. With the switch in the AUTO position the contacts 1 & 2 are closed which feeds the pump relay K4, thus completing the positive side of the control circuit. The 36V negative side of the circuit starts when the operator throttle pot input to A1 speed control causes the P1 connection on the controller to output a negative voltage for the L1 & K4 contactor coils. This provided output passes through the normally closed (none activated) directional switch (S6) when in forward. Note: The (S6) direction switch circuit changes opens when the operator drive paddle is moved into reverse. The S6 Org/Blk wire feeds the needed (Neg.) circuit input to the L1 coil and S4 pump switch contacts 4 & 5 to complete the K4 coil circuit. Thus both the L1 & K4 are energized. With K4 turned on the load contact closes and the pump runs and the L1 solenoid valve opens to allow the pump flow output to be directed to the nozzle selected.

FIGURE 3

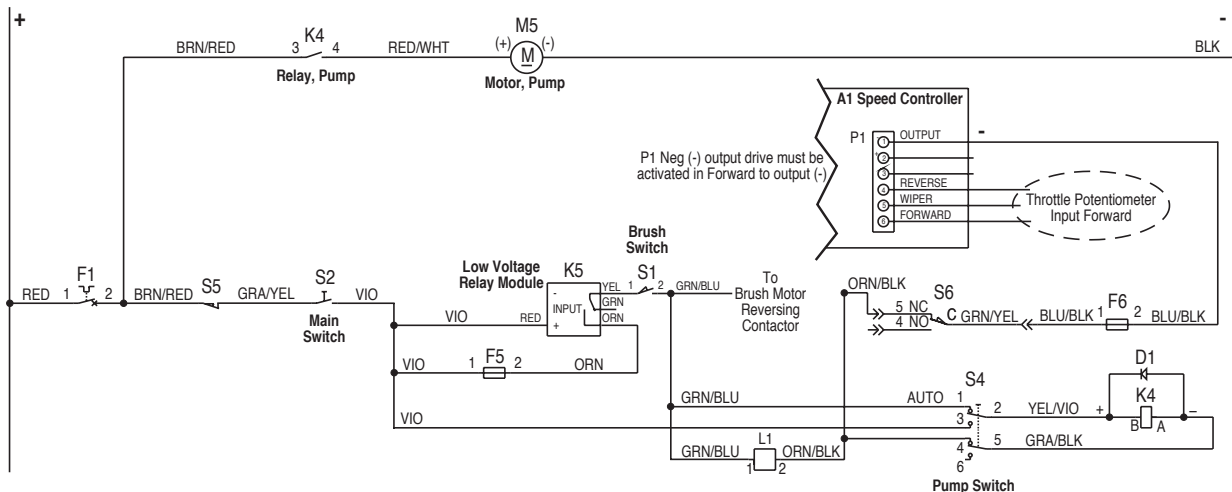

Note 1: See the Electrical System *Description of Low Voltage Cutout*.

BASIC TROUBLESHOOTING SOLUTION SYSTEM

Mechanical / Electrical / Plumbing

Problem	Possible Cause
Inadequate or no solution flow	No solution in the tank
	Main solution control knob in the incorrect usage position (maintenance or restoration), also travel speed could be too fast.
	Clogged solution filter, valves, hoses and nozzles
	Defective solution solenoid valve (L1)*
	Defective solution pump switch (S4)*
	Defective solution pump relay (K4)* or pump motor (M5)*

* See the Troubleshooting flow charts symptoms 1 & 2 in this manual section for electrical system diagnostics.

TROUBLESHOOTING GUIDE SOLUTION ELECTRICAL

Possible Symptoms

- 1 No solution when operating in the On accessory mode.
- 2 No solution when operating in the Auto extraction mode.

SYMPTOM ONE

Note: Do all testing with the master key switch (S2) ON, pump switch (S4) in the ON position, and attach a portable extraction tool to the solution accessory port and operate the tool.

Part A: Pump Motor M5 Load Circuit Troubleshooting Guide

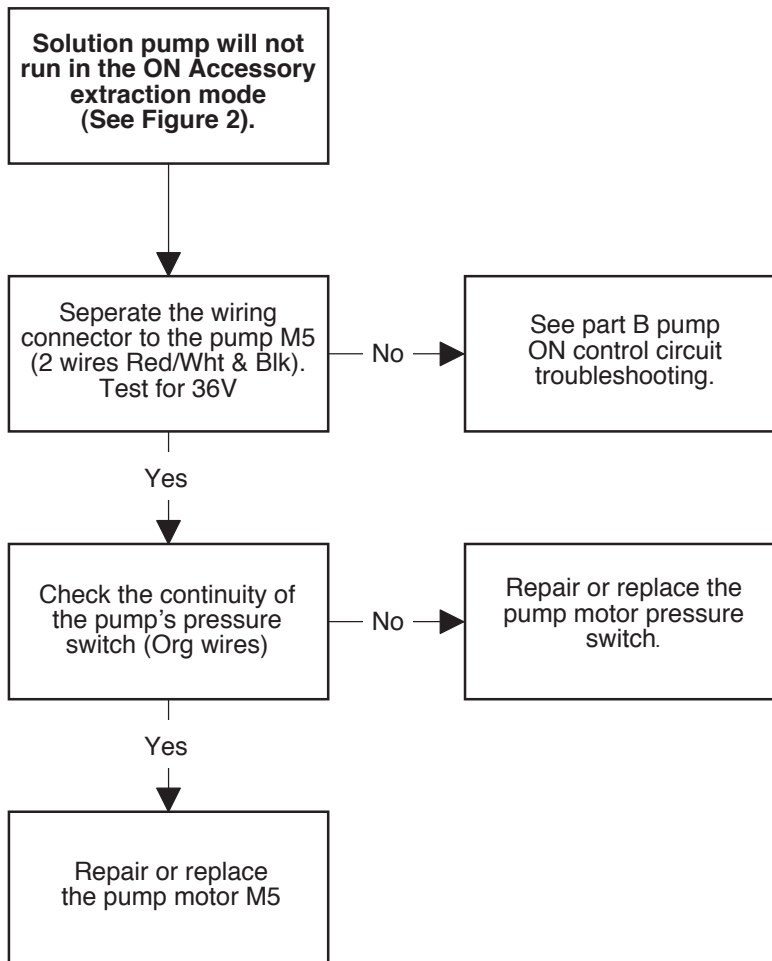

SOLUTION SYSTEM

TROUBLESHOOTING GUIDE SOLUTION ELECTRICAL (CONTINUED)

SYMPTOM ONE

Note: Do all testing with the master key switch (S2) ON, pump switch (S4) in the ON position, and attach a portable extraction tool to the solution accessory port and operate the tool.

Part B: Pump Motor M5 Control Circuit Troubleshooting Guide

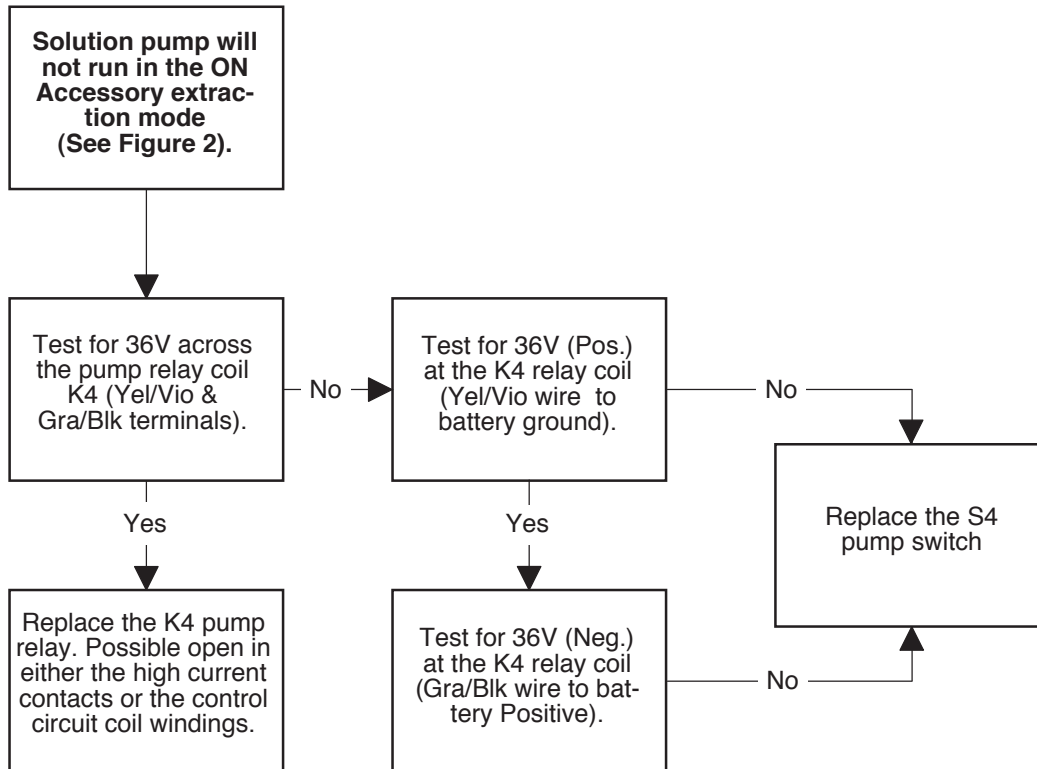

SOLUTION SYSTEM

TROUBLESHOOTING GUIDE SOLUTION ELECTRICAL (CONTINUED)

SYMPTOM TWO

Important Troubleshooting Service Tip: Before starting electrical circuit troubleshooting test the solution system Auto operation in both Maintenance & Restoration modes. If the pump runs only in one mode and not the other it is important to check for a major restriction in that nozzle circuit.

Note: Do all testing with the master key switch (S2) ON, pump switch (S4) in the AUTO position and the brush switch (S1) closed (brush lever lowered). Also have the drive wheel raised off the floor and the drive paddle activated in Forward drive.

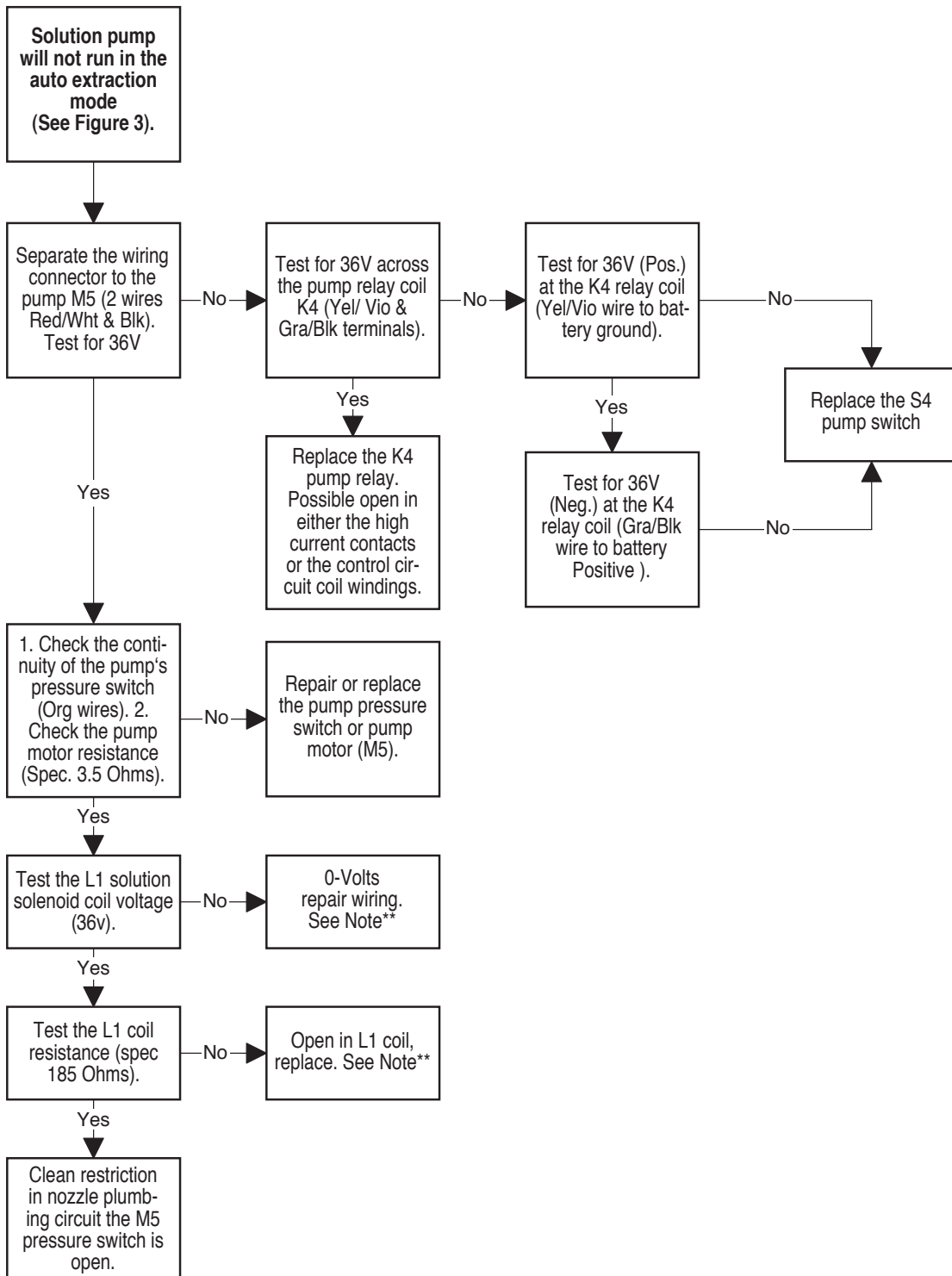

****L1 Solution Solenoid Diagnostic Note:** If L1 measures 0-volts or open resistance the solenoid valve port remains closed and blocks the (M5) pump's output. This causes the pump's internal pressure switch to open and the pump can't run.

SOLUTION SYSTEM

MAJOR COMPONENTS SPECIFICATIONS

Nozzle and Pump Data	
Components	Flow Rate GPM / Working Pressure
Nozzle (A) "Maintenance" Spec. .033" orifice diameter Hardened Stainless Steel PN SS1	.28 GPM 92 PSI
Nozzle (B) "Restoration" Spec. .073" orifice diameter Hardened Stainless Steel PN SS5	.96 GPM 75 PSI
Standard Accessory Aqua Kit Tools	.55 GPM 76 PSI
Pump Specifications	Pressure relief switch opens at 100 PSI Max. flow rate 1.6 GPM Max. current 3A (average current 2.7A)

NOZZLE MAINTENANCE

See Figure 5. To inspect and clean both nozzles no tools are needed. First remove the Wing Nut (**D**) that secures the nozzle bracket (tree) and pull it from the brush housing slots with the hoses still connected.

To remove a nozzle to clean or replace just grip the nozzle tip and at the same time press in and twist it a 1/4 turn to separate it from the nozzle body. Note: Suggested once a week to inspect and clean nozzles.

Clean by soaking nozzles overnight in a full strength vinegar solution or properly diluted and handled meratic acid solution to remove build up of chemical deposits. Note: Do not ream out (increase) the orifice by cleaning with a drill bit. As this will affect the nozzle working pressure and spray pattern.

NOZZLE FIXTURE INSTALLATION

- 1 Apply small amount of thread sealant (Loctite #242-blue) to the fixture threads.
- 2 See Figure 4. Thread the Nozzle Fixtures (**K**) into each brass barb.
- 3 Position nozzle fixture as shown (nozzle fixture flat must be 90° to bracket arm).

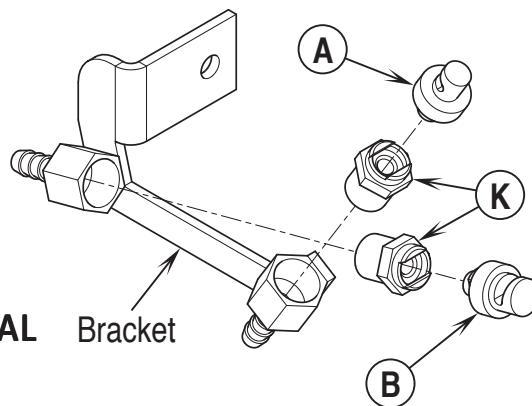
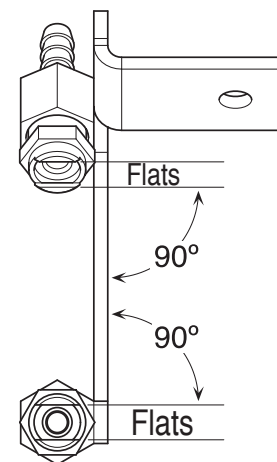

FIGURE 4



SOLUTION PUMP REMOVAL

⚠ WARNING!

Disconnect a battery cable before servicing machine.

- 1 Drain the solution system using the machine's drain hose.
- 2 Block the rear caster wheels to prevent the machine from rolling. Then jack up the front of the machine 3 inches (76 mm) using an automobile type scissors jack.
- 3 See Figure 5. Loosen the two Hose Clamps (**E & F**) and remove the hose ends from the tank outlet and pump outlet.
- 4 Cut the pump wiring harness tie strap and disconnect the pump's wiring connector.
- 5 Remove the two Hex Nuts (**G**) that secure the Pump Bracket (**H**) to the chassis and pull it out from under the machine.
- 6 Remove the (4) pump housing frame mount Screws (**I**) and Nuts (**J**) to complete the removal of the pump from the Bracket (**H**). Note: Inspect and make needed service repairs and salvage the hoses, filter and hose clamps. Then reinstall following the above steps in reverse order.

SOLUTION SYSTEM

FIGURE 5

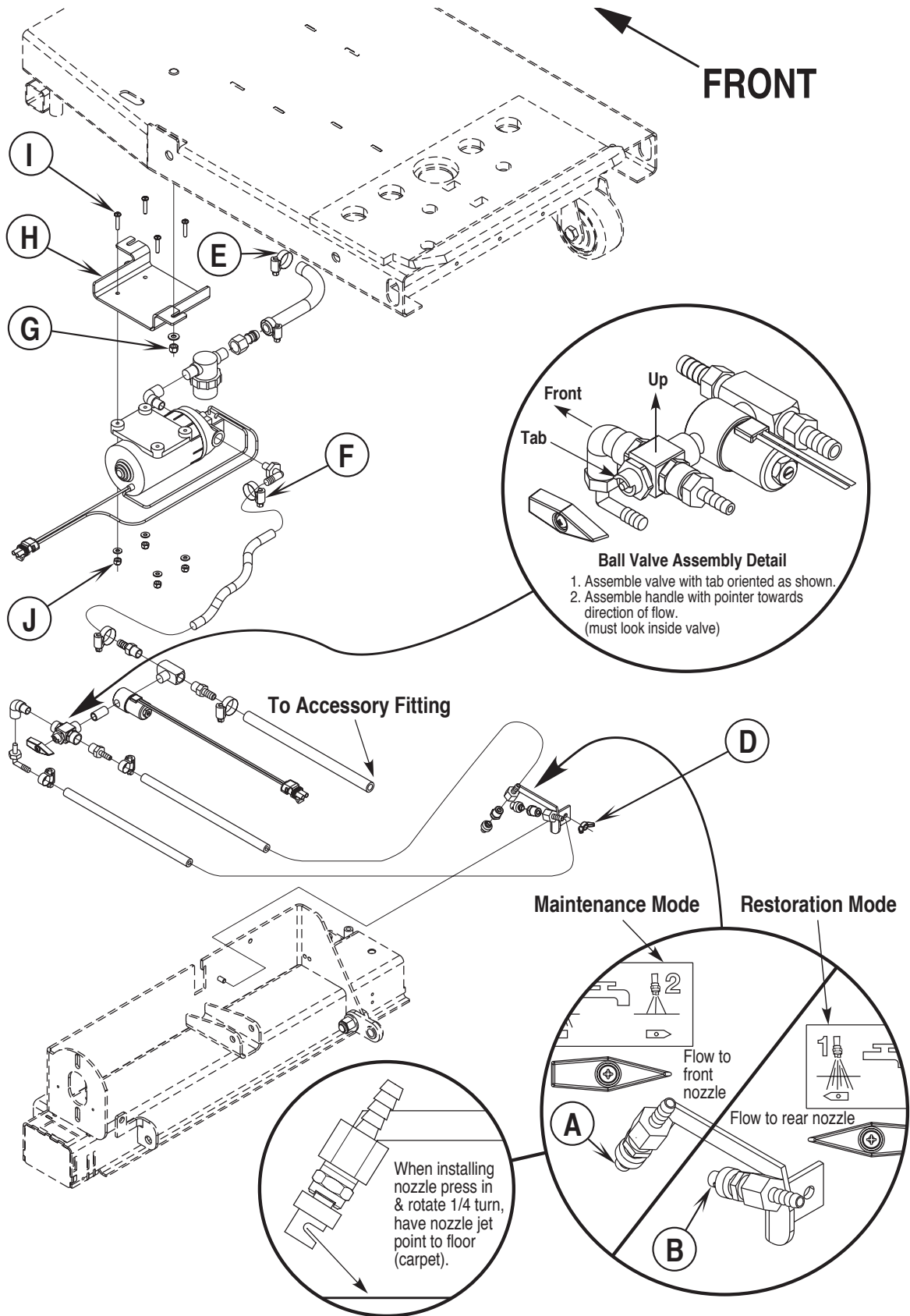

SCRUB BRUSH SYSTEM

GENERAL BRUSH SYSTEM OVERVIEW

The AquaMAX™ and AX 650 models both use (1) cylindrical scrub brush (3-5/32" Dia. x 24-1/2" length) powered by a 1/2 HP permanent magnet motor through a poly V-belt and (2) pulley transmission drive. The brush deck and vacuum pick-up shoes are raised and lowered manually by a rear control panel mounted lever. The brush rotation matches the drive wheel selected direction. With forward machine movement the brush rotates CCW (counter clockwise) and in reverse CW (clockwise) observed from the drive belt end. A knob and load (Amp) meter gauge adjusts the brush height (working pressure). Note: See the Know Your Machine section for a more detailed explanation in reading the load meter.

SCRUB BRUSH MOTOR RUN FUNCTION

Scrub Control Circuit

See Figure 1. To turn on (energize) the K1 brush motor Fwd/Rev contactor the operator must lower the brush deck to close the S1 brush switch and also move the drive paddle off neutral to activate the drive wheel.

Forward Reverse Brush Control Circuit Function

These two operator functions described above deliver the required control circuit inputs, one positive and one negative, to start and stop and change direction of the scrub brush motor M2.

The Fwd brush rotation circuit input starts with the closed brush switch S1 completing the battery Pos. inputs to the K1 coil terminals (Grn/Blu wire). The Neg. circuit input is triggered when the machine is put in motion. The A1 speed control's P1 connection pin #1 sends a Neg. output signal to the (S6) direction switch. The direction switch is normally closed when the drive paddle is selected for Fwd drive. Thus the Org/Blk wire completes the needed neg. control circuit voltage to the K1 Fwd coil terminal. For the reverse brush rotation circuit to change when in reverse machine operation, the direction switch S6 normally open terminal contacts are closed (switch actuator arm compressed) and the speed control's Neg. P1 signal is sent to the K1 reverse coil terminal (Gra wire). This then completes the K1 Fwd/Rev coils control circuits (pos. & neg.) and pulls in the selected load contact making the motor run.

Forward Reverse Brush Load Circuit Function

The battery pack's Pos. high current circuit passes through a 20 Amp circuit breaker (F2) and the ammeter (P1) to the selected closed K1 Fwd/Rev contacts (B or C). Example: Forward direction selected, the pos. voltage passes through the closed contact A/B (Yel/Blk & Wht/Vio) to the M2 motor. The neg. side of the circuit passes through the contacts D/C (Blk & Blk/Wht) to the M2 motor.

FIGURE 1

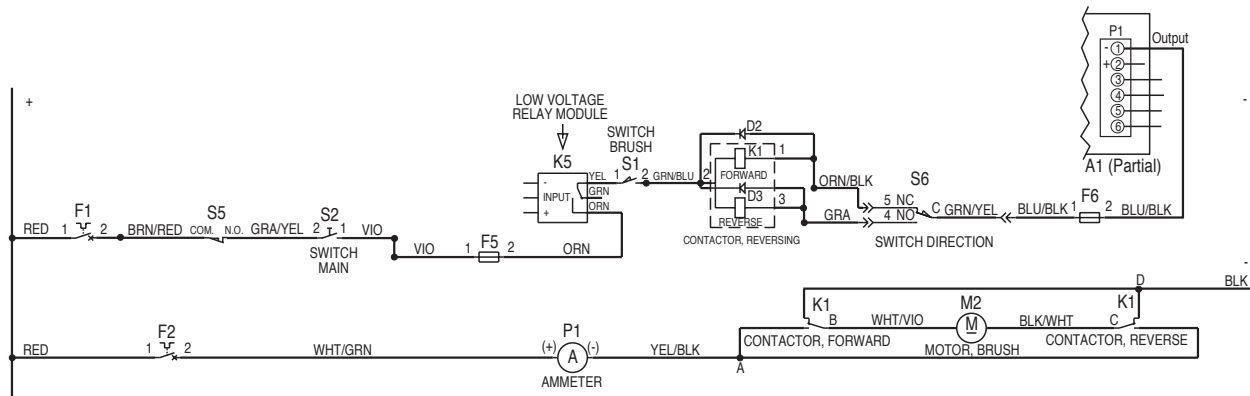

Electrical Diagram

For complete description of all callouts see Electrical System *Wiring Diagram*.

SCRUB BRUSH SYSTEM

TROUBLESHOOTING GUIDE ELECTRICAL

Possible Symptom

- 1 Scrub brush motor does not run.

SYMPTOM ONE

Note: Do all testing with the key switch (S2) ON, brush switch (S1) closed (scrub deck lowered) and the drive paddle activated (push FWD/pull REV). Also check the scrub brush circuit breaker F2 and reset it before doing any further electrical testing.

Service Tip: See Figure 1. This machine is equipped with a low battery voltage cutout relay K5. The relay opens the positive control circuit voltage to the S1 brush switch when the batteries are discharged to a value of 31.5 volts. This causes all the S1 down stream circuits to be shut off (brush, auto solution and auto vacuum).

Part A: Scrub Brush Motor Does Not Run Load Circuit Troubleshooting Guide

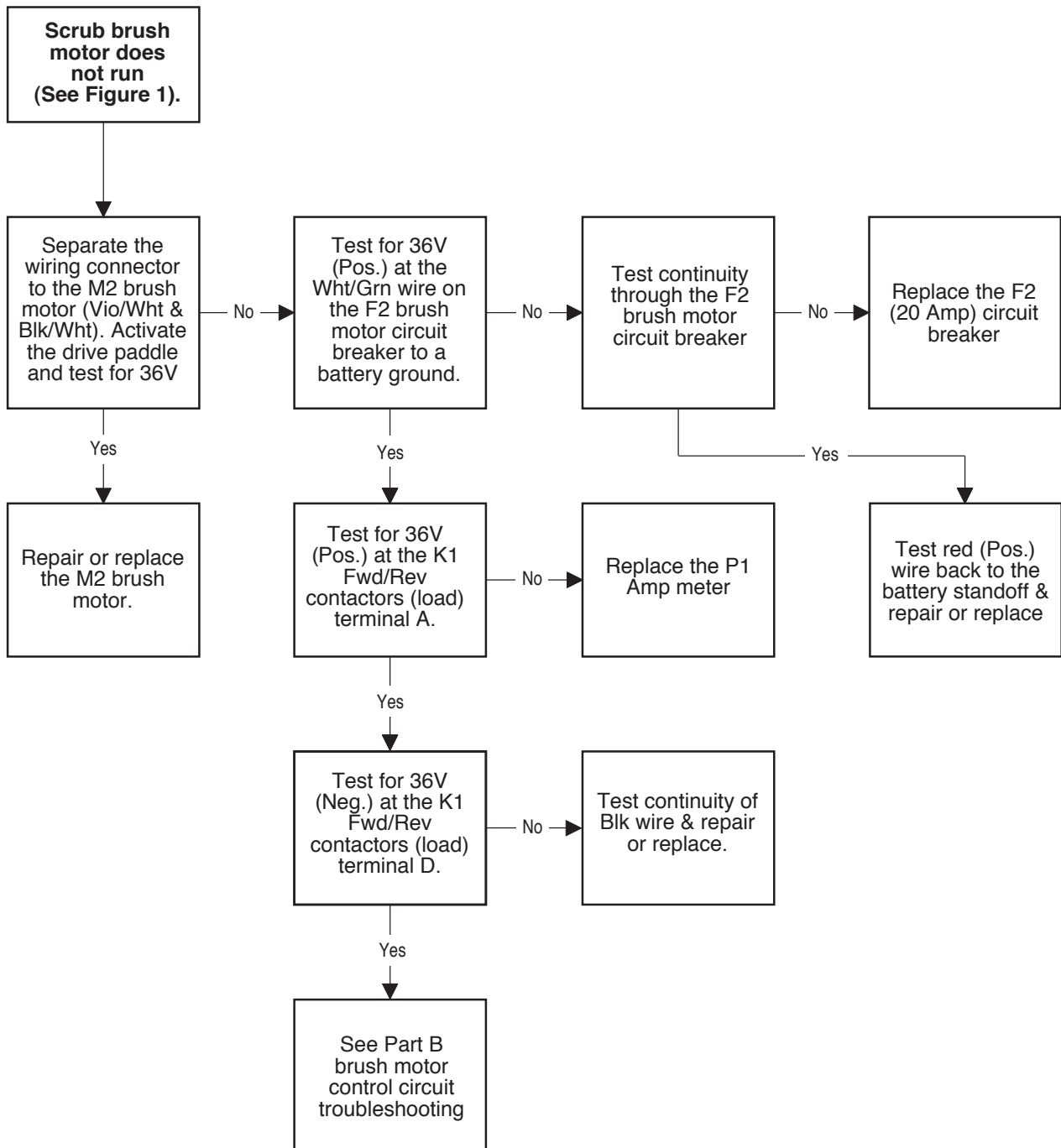

SCRUB BRUSH SYSTEM

TROUBLESHOOTING GUIDE ELECTRICAL (CONTINUED)

SYMPTOM ONE

Note: Do all testing with the key switch (S2) ON, brush switch (S1) closed (scrub deck lowered) and the drive paddle activated (push FWD/pull REV). Also check the scrub brush circuit breaker F2 and reset it before doing any further electrical testing.

Service Tip: See Figure 1. This machine is equipped with a low battery voltage cutout relay K5. The relay opens the positive control circuit voltage to the S1 brush switch when the batteries are discharged to a value of 31.5 volts. This causes all the S1 down stream circuits to be shut off (brush, auto solution and auto vacuum).

Part B: Scrub Brush Motor Does Not Run Control Circuit Troubleshooting Guide

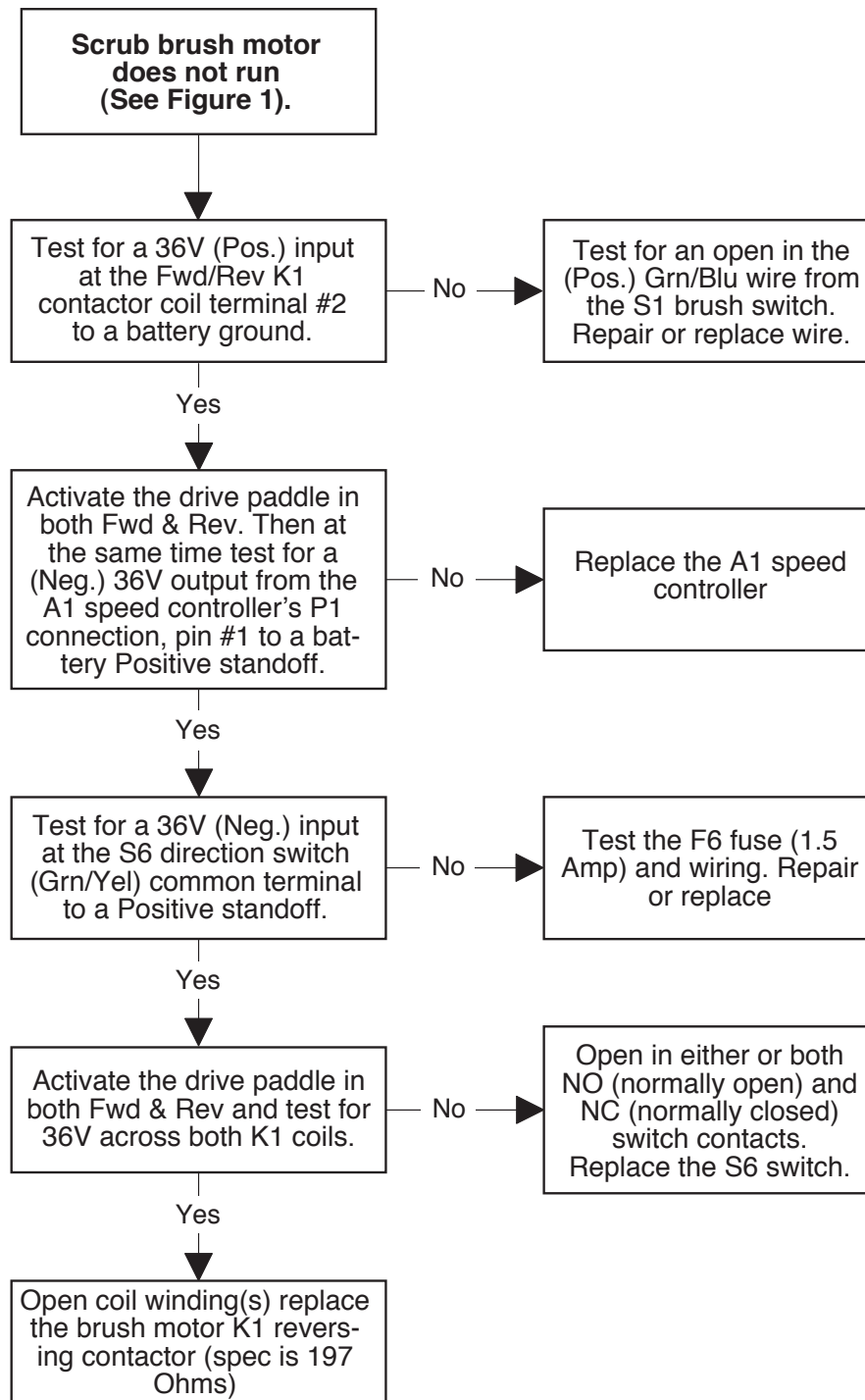

SCRUB BRUSH SYSTEM

SCRUB BRUSH MOTOR REMOVAL

WARNING!

Disconnect a battery cable before servicing machine.

- 1 With the brush deck in the raised storage position disconnect the left side recovery hose from its pick-up tool.
- 2 See Figure 2. Remove the Belt Guard (A) and loosen the two (B) Motor Mount Nuts.
- 3 Turn the belt tensioner Screw (C) CCW (counterclockwise) to relieve tension and remove the Belt (D) from the motor pulley.
- 4 Lower the brush deck to the floor, remove the Nut (E) and separate the Lift Rod (F).
- 5 Locate under the lower right side of the electrical panel the motor harness and disconnect, also unsnap the strain relief clip freeing the wire.
- 6 Remove the Wing Nut (G) and move the nozzle bracket out of the way.
- 7 Remove the two (B) Nuts and slide the motor out from the brush deck housing.
- 8 Reassemble in reverse order and tension the belt as shown in Figure 2.

SCRUB BRUSH ASSEMBLY REPLACEMENT

Service Note: The brush bristles wear limit is 3/8 inch (9.5 mm) a new brush bristle measures 11/16" (18 mm). The brush is only sold in a Kit PN 56212240, which includes installation instructions, a belt, a partially assembled brush roll w/bearings (idler end) and the drive pulley/bearing assembly (brush motor end). The same instructions are used here to support service inspection and numerous system part replacement needs.

WARNING!

Disconnect batteries before servicing.

- 1 Disconnect recovery hoses from pick-up tools.
- 2 See Figure 2. Lower Brush Deck to floor, remove Nut (E) and disconnect Linkage Arm (F).
- 3 Disconnect Brush Motor wiring from machine harness.
- 4 Remove Wing Nut (G) and move the Nozzle Bracket out of the way.
- 5 Remove Screws (H & I) and remove Plate (J). Slide Rod (K) out of the machine.
- 6 Slide the Brush Deck Assembly away from the machine.
- 7 Unsnap Latch (L), remove Pin (M) and Brush Access Door (N). Slide the brush out of the brush deck housing.
- 8 Remove Belt Guard (A) and loosen Screw (C).
- 9 Loosen the (2) (B) Nuts and remove Belt (D) from the motor pulley.
- 10 Remove Pulley Cover (O) and then Bearing Block (P). **NOTE:** The bearing block fits very tightly and may need to be forced out of the brush deck.
- 11 Install the new Bearing Block (P) from the kit. **NOTE:** Put the new Belt (D) on the brush pulley first and make sure that when assembled the side of the bearing block with the number "1" molded on it will face down towards the floor as shown. The bearing block fits very tightly and will need to be tapped in.
- 12 Install the new Belt (D) onto motor pulley and tighten by turning Screw (C) clockwise. Re-tighten the (2) (B) Nuts.
- 13 Re-install Belt Guard (A) and Pulley Cover (O).
- 14 Follow steps 1-6 in reverse order to re-install the brush deck assembly onto the machine. **NOTE:** Level the deck prior to installing the brush. Make sure the brush deck assembly is sitting flat on the floor before tightening Screws (H & I).
- 15 Raise the brush deck and install the new brush, make sure the end with the large slots in it is inserted first.
- 16 Reach under the left end of the brush deck and guide the end of the brush onto the drive lug on Bearing Block (P). Make sure the brush is firmly seated on the drive lug.
- 17 Install Bearing Block (Q) onto Brush Access Door (N) if it was removed. **IMPORTANT!** Make sure that the Bearing Block (Q) is seated securely in the door and orientated with round facing up (as shown) for "old style" machines. For "new style" machines the Bearing Block (Q) is attached to the Access Door (N) with Hardware (R). Hold the end of the brush up while re-installing Brush Access Door (N) to ensure that the Bearing Block (Q) is correctly seated on the end of the brush.
- 18 Re-install Pin (M) and re-secure Latch (L). Latch should secure easily. If it has to be forced, recheck the position of the brush.
- 19 Test the machine for proper operation.

SCRUB BRUSH SYSTEM

FIGURE 2

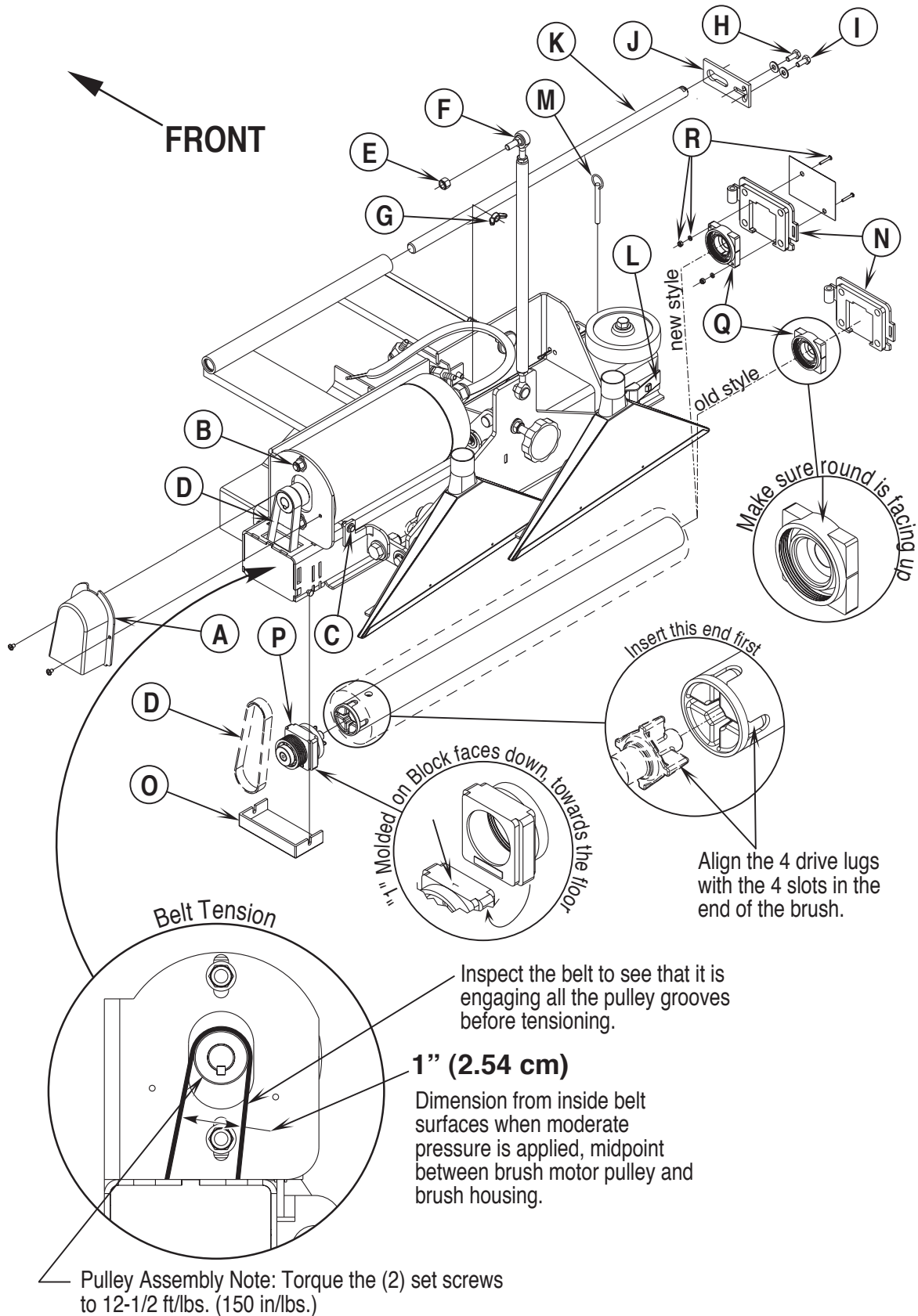

RECOVERY SYSTEM

FUNCTIONAL OVERVIEW VACUUM/RECOVERY SYSTEM GENERAL

To start the extraction wastewater is lifted out of the carpet pile by airflow created by two 3 stage 36V vacuum motors. See Figure 1. The wastewater and air enter at the two vacuum pick-up tools through their small narrow shoe openings that contact the carpet surface. The narrow shape of the shoe openings are designed to help speed up the airflow producing the needed suction to lift the waste water out of the carpet. Two smaller recovery hoses are connected together and direct the high-speed air/water movement to one large hose connected to the tank dome lid inlet. At this point the air and water enters the large flexible sealed recovery bladder. Where the air slows down because of the increased (size) of the tank. With the decreased air speed the heavier water falls to the bottom of the recovery bladder. Then at the same time the airflow continues through shutoff float, vacuum hose, vacuum motors and is exhausted out the bottom of the vacuum motor housing.

The vacuum system uses a shutoff float to prevent the tank from being overfilled and also stops any water from being sucked into the vacuum motors. Note: Under normal operation and maintenance no wastewater should ever enter the vacuum motors, just the working air.

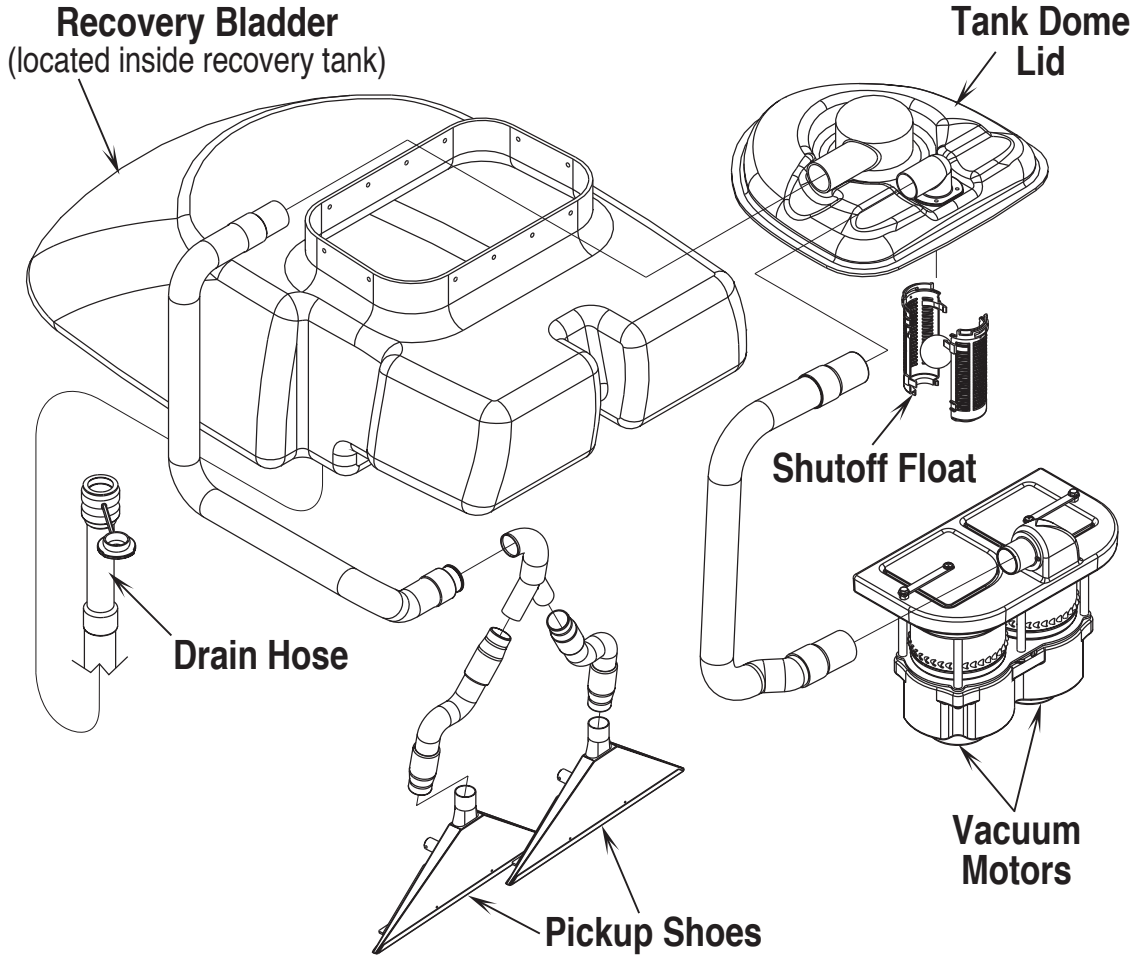

RECOVERY SYSTEM

VACUUM SWITCH CIRCUIT OVERVIEW

There are (2) vacuum switch operator modes, ON for stationary optional accessory use and AUTO for machine transport extraction use. Note: See the Know Your Machine section in this manual for a complete explanation of vacuum switch operation modes.

VACUUM SWITCH ON POSITION CIRCUIT FUNCTION

See Figure 1. With the key switch (S2) closed the Vio wire supplies a 36V (Pos.) input to the vac motor contactor (K3) coil circuit. Therefore completing the positive side of the control circuit. With the vacuum switch (S3) in the ON position the negative ground return circuit side of the vac contactor coil is completed through the switch contacts 5 & 6. This then energizes (closes) the high current K3 load contactor and the vacuum motors run. Note: The vacuum motors will run continuously without any other machine interruptions. To turn off place the (S3) vac switch in its middle OFF position or turn the main key switch (S2) to its off position.

FIGURE 1

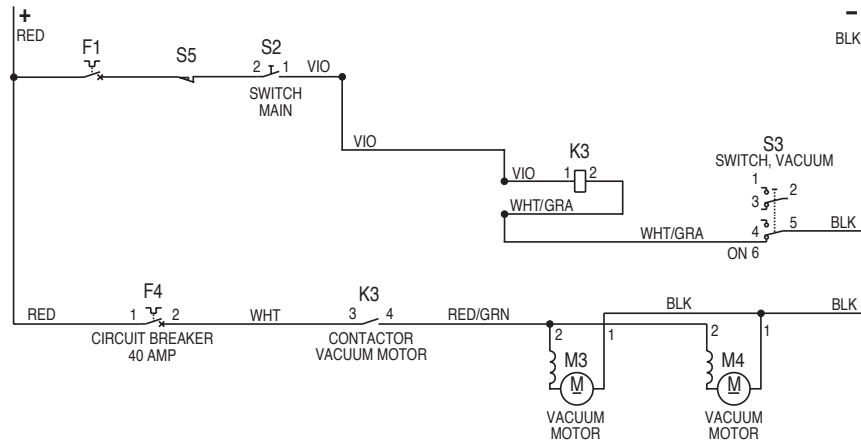

VACUUM SWITCH AUTO POSITION CIRCUIT FUNCTION

See Figure 2. With the key switch (S2) closed the Vio wire supplies a 36V (Pos.) input to the vacuum motor (K3) contactor coil. Therefore completing the positive side of the control circuit. With the vacuum switch (S3) in the AUTO position its switch contacts 5 & 4 provide the negative ground return circuit path from the Wht/Red wire connected to the (*E2) time delay #1 terminal.

The time delay's operation begins with the brush switch (S1) closed and the Grn/Blu wire supplying a Pos. 36V initiating (start) signal to the time delay at terminal #6. The initiating (start) signal causes an internal relay switch to close connecting the pin terminals 1 & 2 to the (neg.) battery ground. The #2 (Wht/Gra wire) then completes the K3 coil circuit and also energizes (closes) the high current K3 load contactor making the vacuum motors run. Note: When the operator raises the brush deck lever the S1 switch opens and the input voltage signal to the E1 time delay is lost. This causes the timer circuit's battery negative return path at terminal #2 to open after 10 seconds. The result is the K3 coil circuit is interrupted (opened) and the vacuum motors stop running.

FIGURE 2

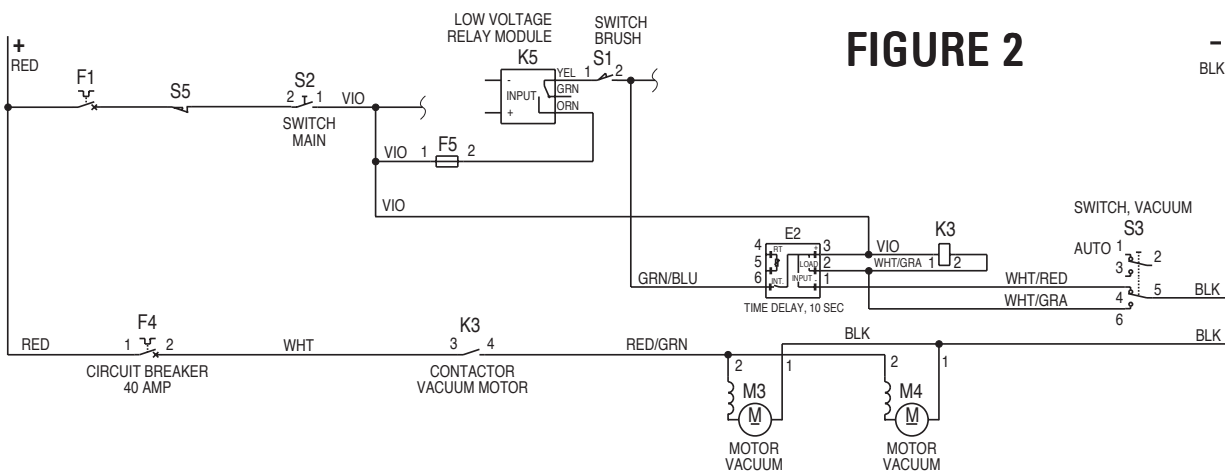

* E2 Note: The purpose (use) of the time delay is to allow the vacuum motors to run an additional 10-seconds after the operator raises the vacuum pick-up shoes up off the carpet. The extra run time prevents any remaining water in the hoses from draining back on to the carpet.

RECOVERY SYSTEM

VACUUM / RECOVERY SYSTEM SERVICE MAINTENANCE CHECKLIST

Whenever there is a vacuum problem it's best to check over the entire system. Use the checklist below as a guide, to thoroughly check the vacuum system.

- Clean built-up dirt from the inside of both vacuum pick-up (shoes) tools.
- Inspect the vacuum motor module housing gaskets and clean filters.
- Inspect the hoses between the pick-up tools and the recovery tank, rinse any built-up dirt from the hoses. Replace the hose(s) if it is kinked or damaged.
- Inspect and make sure the gasket on the recovery tank cover is sealing and not damaged.
- Inspect and clean the vacuum motor shut off float cage.
- Make sure that the recovery tank drain hose cap seals airtight.
- Inspect and clean the vacuum hose between the recovery dome lid and motor module plenum housing.

TROUBLESHOOTING GUIDE

When extracting the operator sees little or no waste recovery water entering the recovery tank dome lid, the vacuum system is not working properly. When a vacuum system performs poorly, it is usually because of one of the following problems:

Vacuum Leak(s) – Air flowing into the vacuum system past a bad gasket or leaky hose, damaged tank, or a leaky drain hose cap. A vacuum leak below the water line will create turbulence in the recovery tank, causing water to enter the vacuum filter and motor.

Restriction(s) – Anything that blocks the flow of air through the system. Restrictions may also be caused by built-up debris in the pick-up tool, vacuum hoses, float cage or wherever the airflow is forced to make a sharp turn.

Both leaks and restrictions decrease the quantity of air flowing through the pick-up tool. The air that does go through the pick-up tool moves slower, so it has less pick-up power.

RECOVERY SYSTEM

TROUBLESHOOTING GUIDE ELECTRICAL

Possible Symptoms

- 1 Vacuum motors will not run in the on accessory mode.
- 2 Vacuum motors will not run in the auto extraction mode.

SYMPTOM ONE

Note: Do all testing with the master key switch ON, vacuum switch S3 ON.

Part A: Vacuum Motor Load Circuit Troubleshooting Guide

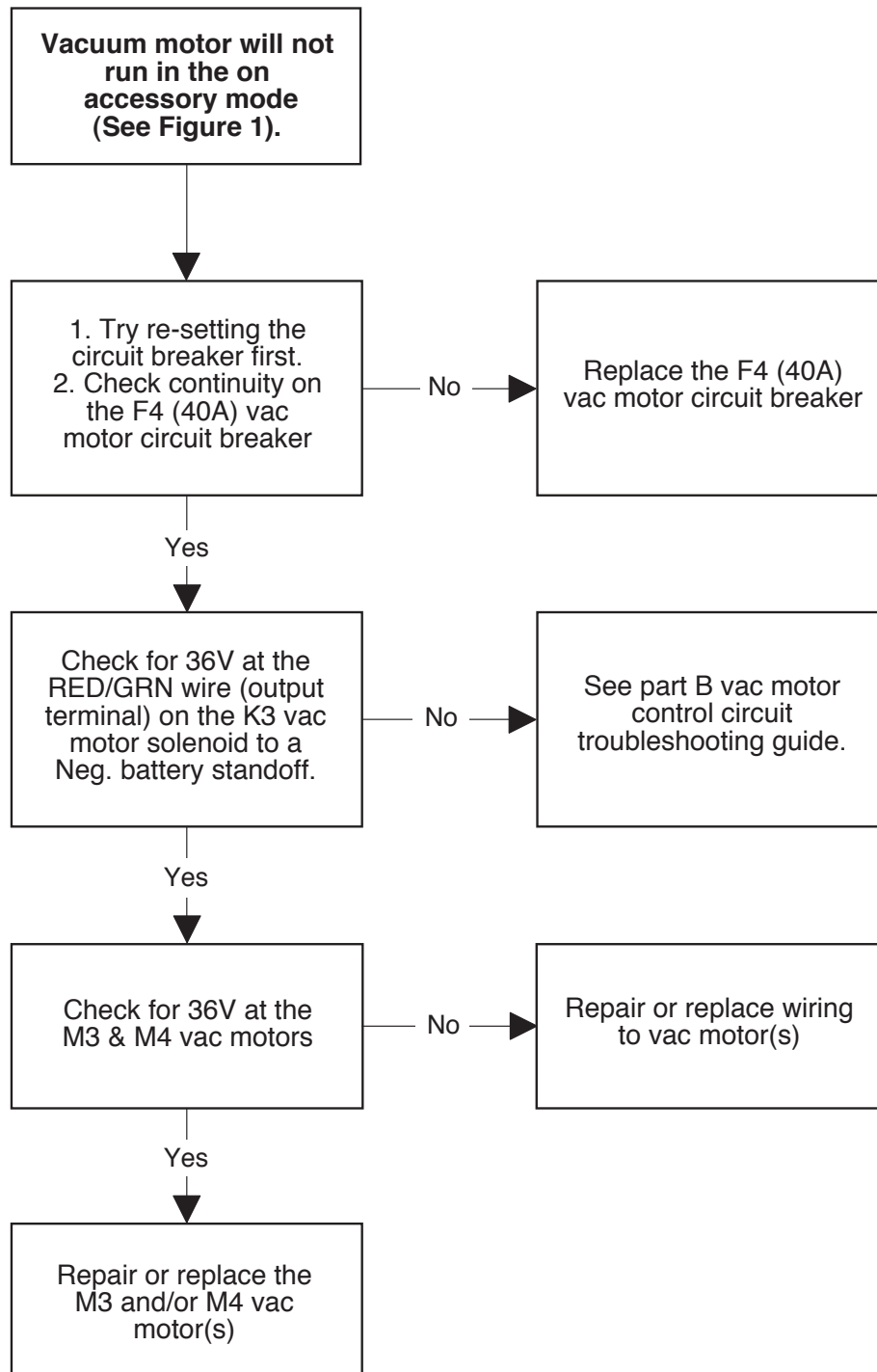

TROUBLESHOOTING GUIDE ELECTRICAL (CONTINUED)

SYMPTOM ONE

Note: Do all testing with the master key switch ON, vacuum switch S3 ON.

Part B: Vacuum Motor Control Circuit Troubleshooting Guide

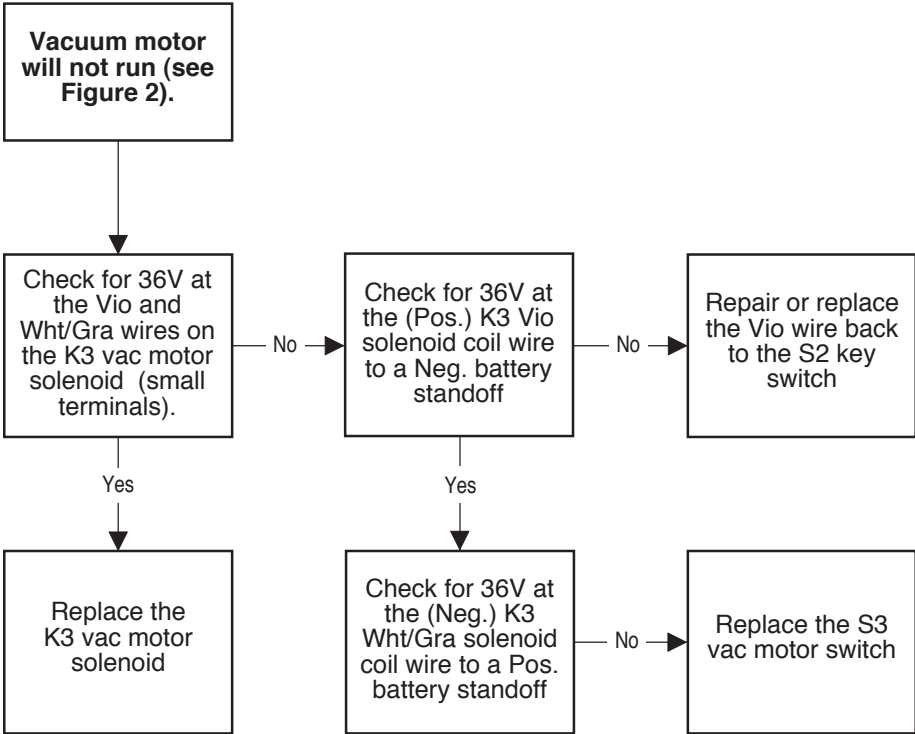

RECOVERY SYSTEM

TROUBLESHOOTING GUIDE ELECTRICAL (CONTINUED)

SYMPTOM TWO

Note: Do all testing with the master key switch (S2) ON, vacuum switch S3 in the auto position and the brush switch (S1) closed (brush lever lowered).

Part A For the vacuum motor load circuit troubleshooting guide follow the steps for the on accessory mode load circuit.

Part B Vacuum motor control circuit troubleshooting guide.

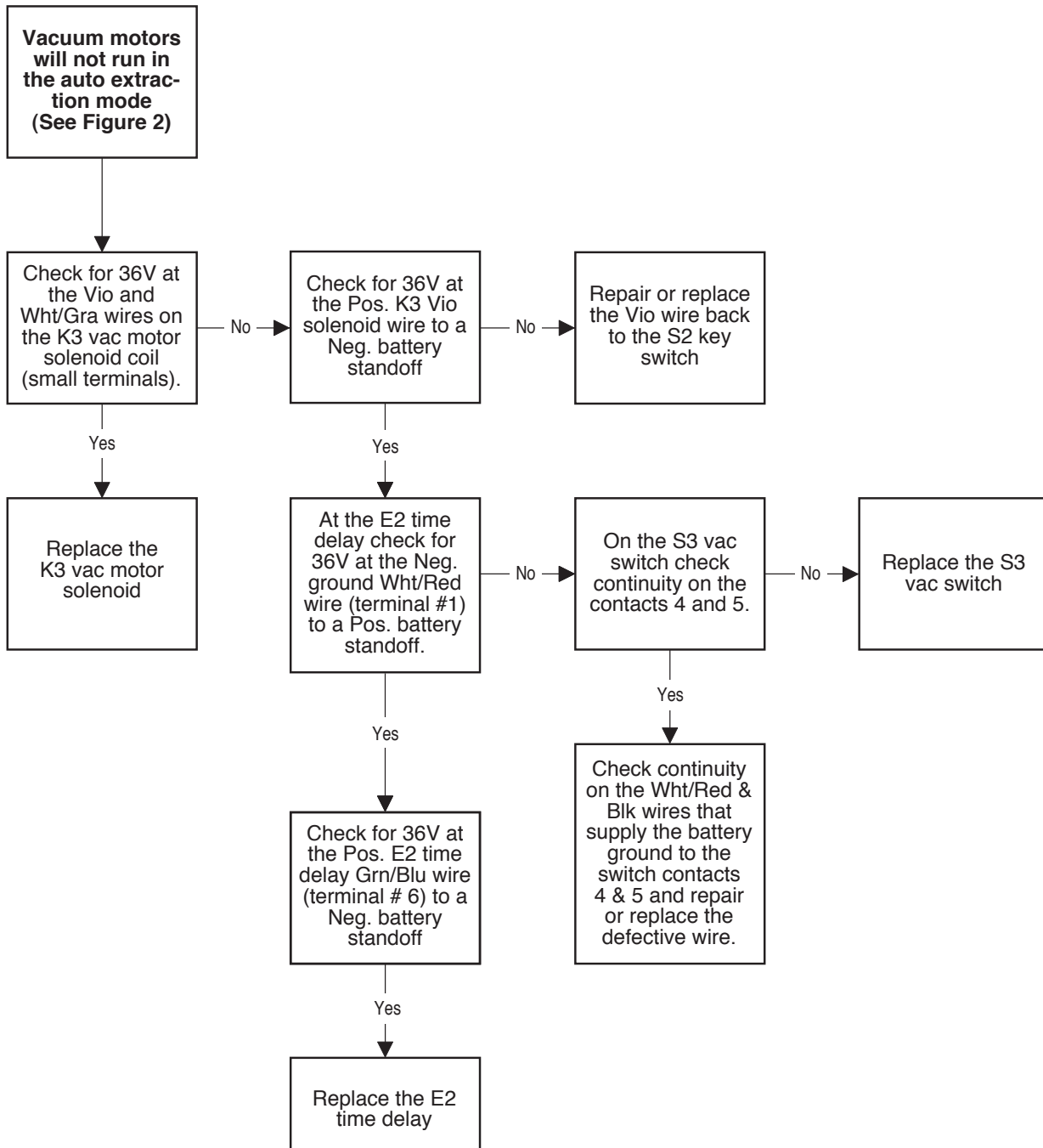

RECOVERY SYSTEM

VACUUM MOTOR REMOVAL

⚠ CAUTION!

Note have the key switch in the Off position before servicing.

- 1 Drain the recovery tank using the drain hose.
- 2 Unlock the rear tank latch then swing open the recovery tank and secure with prop rod.
- 3 Loosen vacuum motor hose clamp and remove the hose from the vac motor housing inlet tube.
- 4 Lift the vacuum motor module straight up and rest it on the lower tank wall. Next disconnect the (2) separate motor wiring harness plugs and complete the removal of the motor housing module from the machine.
- 5 See Figure 3. Using the vacuum motor assembly illustration disassemble and inspect. Make needed service repairs and re-install by following the above listed steps in reverse order.

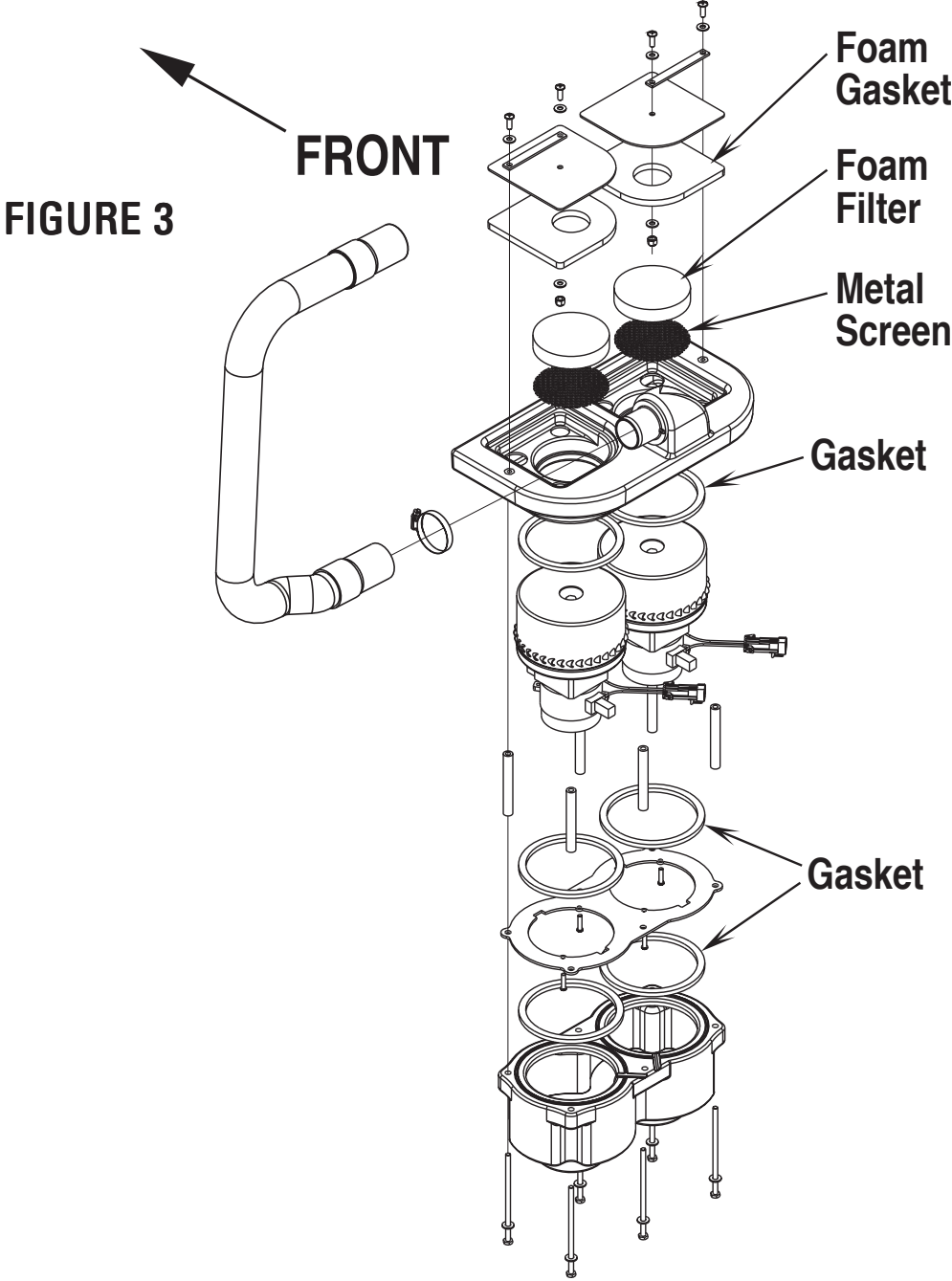

RECOVERY SYSTEM

RECOVERY BLADDER REMOVAL

- 1 Drain both the solution section and the recovery section in the upper tank. Then unlatch the tank and swing open setting the prop rod support.
- 2 See Figure 4. Remove the (3) item **(A)** Hex Nuts that secure the center of the Brace **(B)** to the **(C)** Tank Drain Elbow Weldment.
- 3 Remove the (3) **(D)** Screws that secure the tank brace to the tank bottom. Then remove the brace from the tank. Note: Watch for and save the (3) **(E)** Bushings when disassembling (so they are not lost).
- 4 Loosen the hose clamp that secures the Drain Hose **(F)** and remove the hose from the end of the drain elbow. Next remove the (6) **(G)** Nuts from the **(I)** Bladder Weldment Ring (studs) and pull loose the elbow also saving the Gasket **(J)**.
- 5 Disconnect the two dome lid cover hoses and remove the hardware that secures the Cover Straps **(K)** to allow removal of the lid.
- 6 Next remove the remaining (10) **(L)** Acorn Cuts and **(M)** Washers. Then separate the (2) **(N)** Short Bladder Mount Straps and the (2) **(O)** Long Straps from the bladder and tank walls.
- 7 Reach inside the rubber bladder and remove both the **(I)** Bottom Mount Ring and Gasket **(P)**.
- 8 Close the tank then fold the rubber bladder in half lengthwise and pull it up through the tank opening to complete its removal.
- 9 Reach inside the upper solution tank and remove the Gasket **(H)** which goes between the solution tank and the recovery bladder.

RECOVERY BLADDER INSTALLATION

Important Service Tip: Inspect the rubber bladder for any possible holes cracks or tears before reinstalling. Also check all the screws, washers and gaskets and if worn or damaged replace to prevent any possible leaks.

- 1 Reverse the above removal steps to reinstall the bladder and torque the (6) bottom tank mount Hex Nuts **(G)** to the specifications shown in Figure 5. Note: See Figure 5 for tank drain hardware assembly detail and the torque procedure to follow in preventing any possible tank leakage.

REMOVAL OF THE UPPER SOLUTION/RECOVERY TANK ASSEMBLY

- 1 Drain both the solution section and the recovery section in the upper tank and all the solution from the lower chassis tank. See Figure 4. Remove the two hoses from the recovery tank lid and pull them out of their clamped storage cavities. Next loosen the hose clamp that secures the **(Q)** solution tanks vent hose and pry it off its barbed fitting located on the lower tank. Pull off the solution sight/drain hose from its upper storage fitting (barb).
- 2 Unlatch the tank and swing it open setting the Prop Rod Support **(R)**. Next remove the Nut **(S)** that holds the chassis end of the prop bar and lower the tank assembly further to its maximum open position.
- 3 Loosen the hose clamp securing the tank solution outlet Hose **(T)** and pull it off and lay it to the side.
- 4 Remove the Control Panel Assembly **(U)** held by (4) screws. Remove the wiring harness strain relief Plate **(V)** held in place with (4) screws. Remove the wiring harness Retainer Strap **(W)** secured to the tank by Screw **(X)**.
- 5 With all the screws removed for the above components the (4) item **(Y)** Screws that fasten the Paddle Handle Assembly **(Z)** can now be removed and with the connected control panel wiring harness (carefully) place all these components on the floor.
- 6 **Service Tip 1: The tank is large and heavy, support the tank bottom with a chair or other suitable object. This is suggested to prevent any possible damage to the molded-in brass tank inserts when removing or installing the tank.** Remove the (4) Screws **(AA)** that secure the Hinge **(BB)** to the recovery tank bottom and have the tank rest on the above-mentioned support to complete the separation of the tank from the machine.

RECOVERY SYSTEM

FIGURE 4

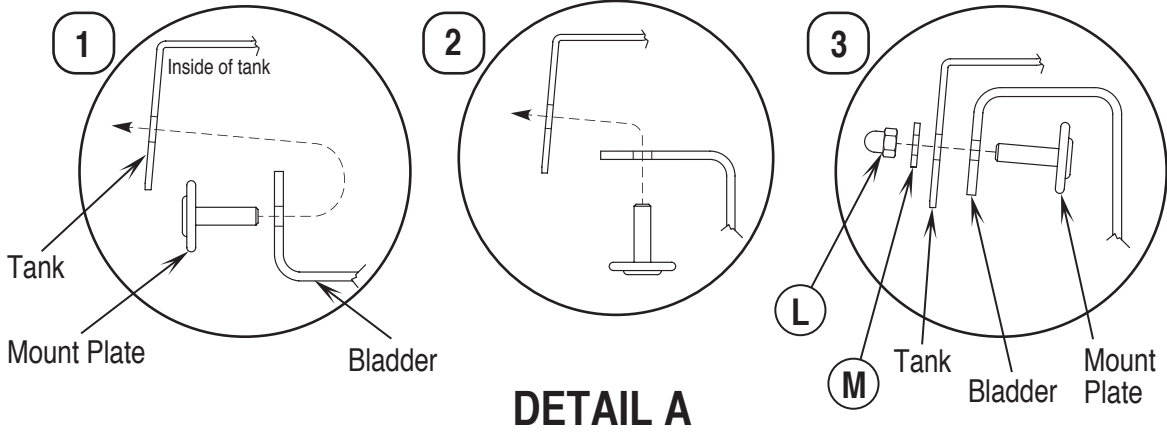
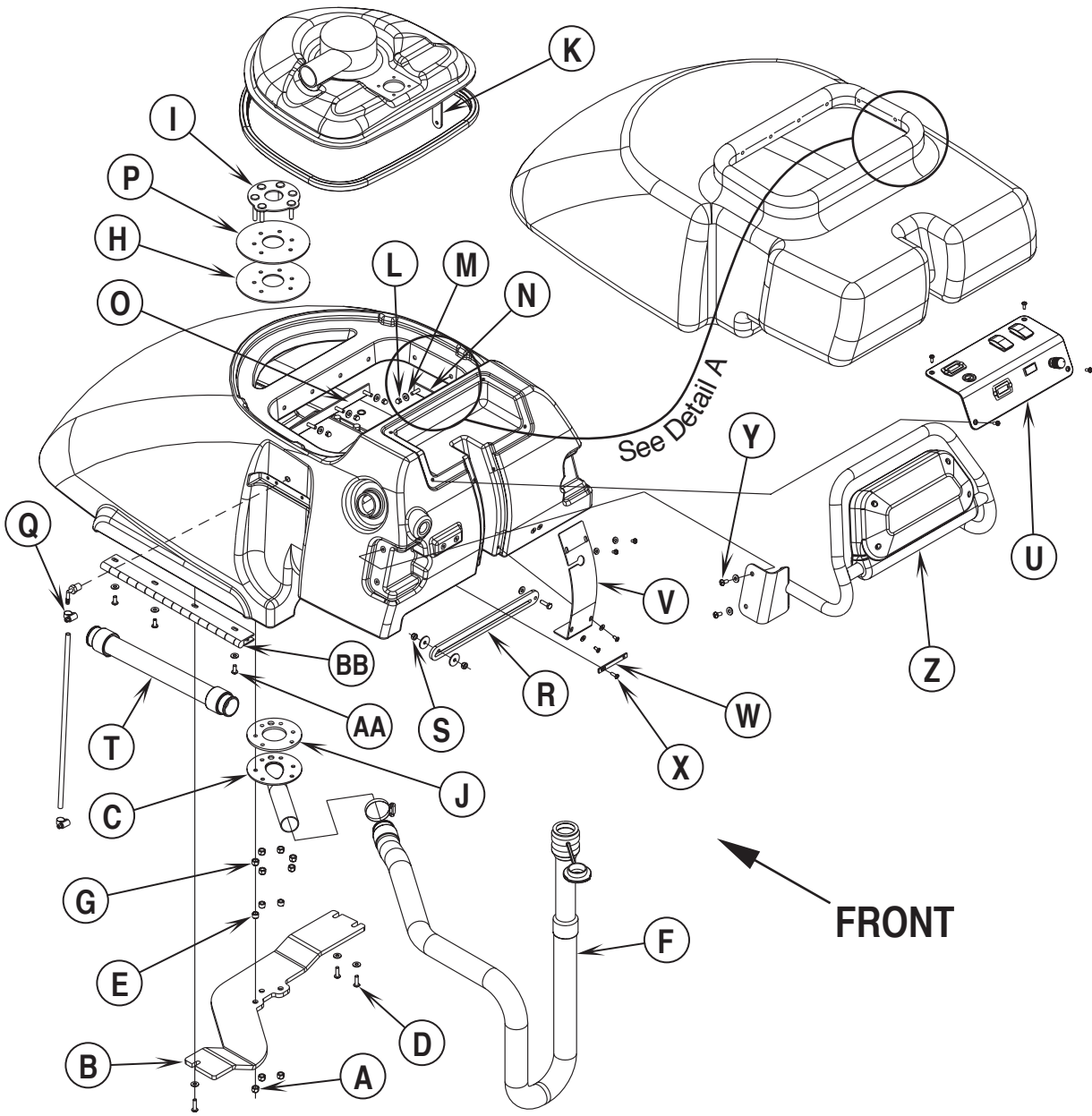

DETAIL A

RECOVERY SYSTEM

FIGURE 5

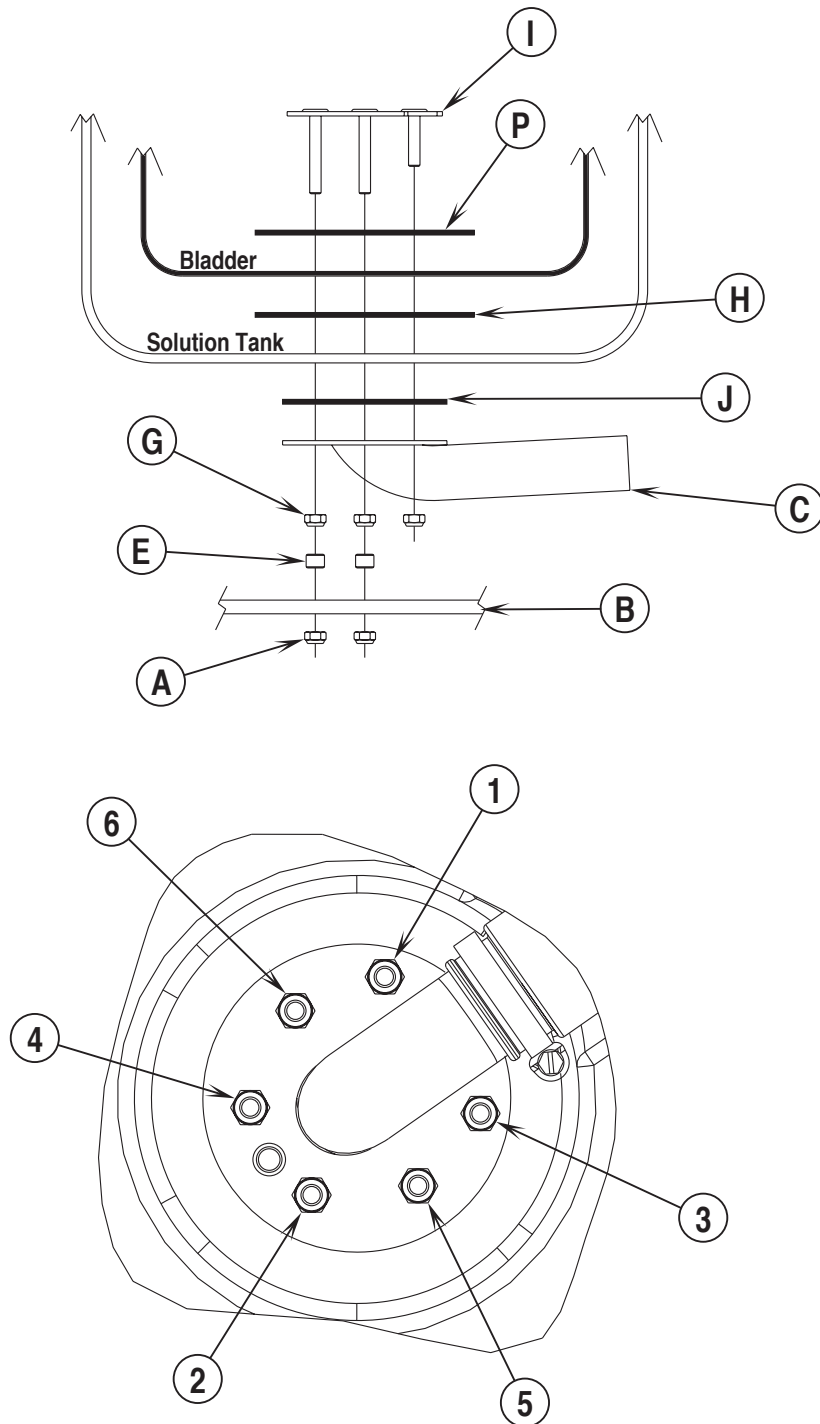

Torquing Procedure for 6 nuts (G):

- 1 Torque nuts in order from 1 to 6.
- 2 Torque each nut to 50 in./lbs.
- 3 Torque each nut to 100 in./lbs.
- 4 Retorque each nut to 100 in./lbs.

WHEEL DRIVE SYSTEM

GENERAL FUNCTIONAL OVERVIEW

A 1/2 horsepower permanent magnet 36V DC motor drives (transports) the machine. See Figure 1. The motor output is delivered to a single front mounted drive wheel driven by a chain. See Figure 2. The speed and direction of the motor is regulated by a solid state speed controller (A1), located in the chassis's rear electrical compartment (mfg. Curtis model 1208). A 5k potentiometer R1 mounted in the drive paddle regulates both machine direction and variable speed demands. The 25K pot R2 mounted in the control panel uses an adjustable knob and controls the machine's maximum transport speed. A third fixed resistor R3 11K Ohms is added into the R2 circuit in parallel. Thus reducing the total circuit resistance and increasing the drive motor's speed when operating in reverse (see the K6 Speed Reverse Relay Function).

Drive Motor System Function

See Figure 2. With the key switch S2 closed the violet wire inputs 36V to the A1 speed controller to make it operational (power it up). The F3 (20Amp) circuit breaker supplies the (Pos.) 36V power input to the B+ (T1) controller terminal (Brn/Yel wire). The black wire from the battery negative standoff supplies the input to the B- (T2) controller terminal. Moving the 5K Ohm R1 direction/throttle pot off its centered balanced neutral setting activates the operator input to the speed control. Forward or reverse movement of the drive paddle rotates the pot shaft and its resistance (variable) changes which generates the internal voltage signals of 0-5 volts needed to determine controller output. This changing voltage value is what energizes the internal Fwd and Rev directional relays, selecting the motor polarity and sending to the motor armature a chopped (*PWM) voltage and current output that varies the motor speed (from the M1 & M2 terminals).

When the operator turns the R2 speed limit pot from min to max clockwise (CW) this causes a controller input resistance change between the pot high (+) and the wiper terminals (high to low Ohms) thus increasing the maximum wheel motor operating speed range. Turning the knob counter-clockwise (CCW) increases the resistance and the motor speed range is reduced.

K6 Speed Reverse Relay Function

The controller's P1 pin #1 outputs a Neg. voltage anytime the R1 pot is in Forward or Reverse. This output is used to change the brush motor rotation with the use of the S6 direction switch (see *Scrub Brush System* for more detail). See Figure 3. Another function of the S6 switch in the drive system is to pull in (energize) the K6 reverse relay coil and create a parallel circuit path for the R2's pot wiper resistance value through the closed K6 load contact. The rule of parallel circuits states the combined resistance is less than the value of any one branch ($R = 1/R1 + 1/R2$). Note: The controller wiper resistance inputs are variable and with the K6 contact closed its path is through both the R2 & R3 thus reducing the total resistance. This causes the M1 drive motor to run faster helping to overcome the sum of the machine's mechanical loads (examples vacuum shoes and caster wheels, etc.).

*PWM; pulse width modulation, also called "chopping" is a technique that switches battery voltage and current On and Off very quickly, thereby controlling the speed of the motor.

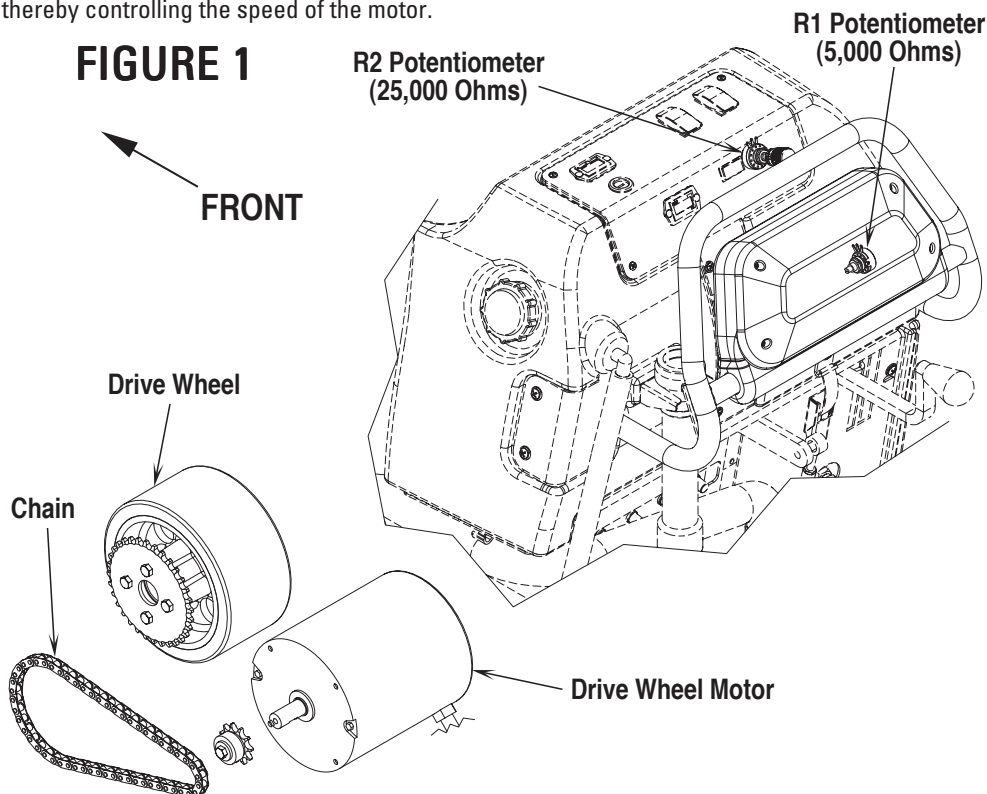

WHEEL DRIVE SYSTEM

FIGURE 2

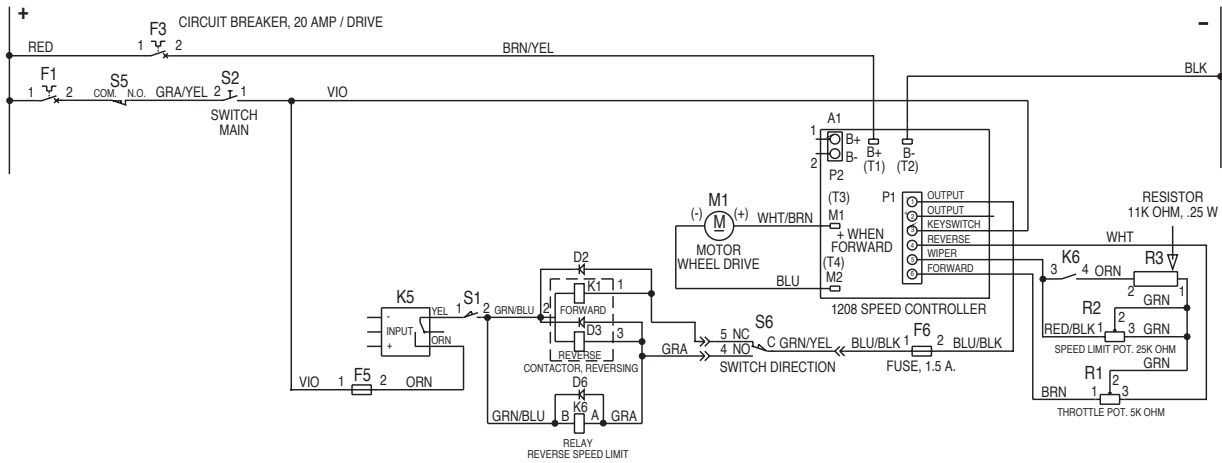

Electrical Diagram

For complete description of all callouts see Electrical System *Wiring Diagram*.

FIGURE 3

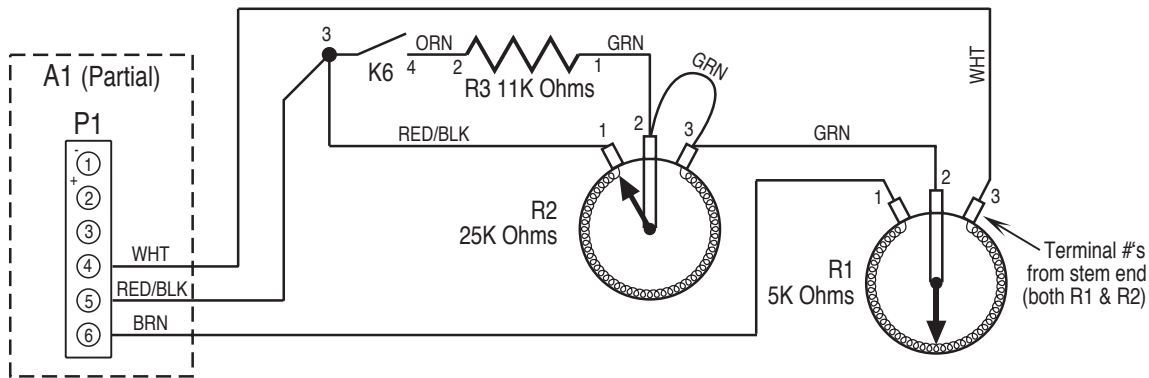

This drawing shows additional controller input circuit detail. The R2 pot is shown at the Max speed limiting setting and the R1 pot in neutral.

WHEEL DRIVE TROUBLESHOOTING GUIDE

Problem	Possible Cause
<ul style="list-style-type: none"> No forward or reverse wheel drive. 	See Electrical Troubleshooting Flowcharts A & B.
<ul style="list-style-type: none"> No wheel drive in one direction, loss of either forward or reverse. 	Controller can't change electrical polarity to wheel motor. Replace the (A1) speed control.
<ul style="list-style-type: none"> Machine creeps (moves) in forward or reverse with only the key switch ON. 	<ul style="list-style-type: none"> Check movement of the drive paddle spring centering device (auto dead-man return to neutral components). Repair or replace needed parts. The R1 drive pot is out of adjustment. Reset to neutral the 5000 Ohm drive paddle potentiometer (*).
<ul style="list-style-type: none"> During normal machine transporting with the 5K drive paddle pot activated the operator also adjusts the control panel maximum speed limiting R2 pot and does not affect the desired maximum machine speed output. 	<ul style="list-style-type: none"> The R2 (25,000 Ohm) speed limiting pot wiper is shorted and machine runs at maximum speed. Replace the R2 pot (**). Note: If the pot wiper is open the machine will not run. Repair pot wiper wiring or pot.

* See *5K Potentiometer Installation and Adjustment* instructions in this manual section and reset the (5K) pot to neutral.

** See *25K Wheel Drive Speed Limit Potentiometer Testing* instructions in this manual section.

WHEEL DRIVE SYSTEM

TROUBLESHOOTING GUIDE ELECTRICAL

Possible Symptom

1 No forward or reverse wheel drive

SYMPTOM ONE

Note: Do all testing with control panel R2 speed limiting pot in the maximum position, the drive wheel jacked up off the floor, key switch ON, and the drive paddle activated (pushed Fwd or pulled into Rev.)

Part A: Wheel drive system motor load circuit troubleshooting guide

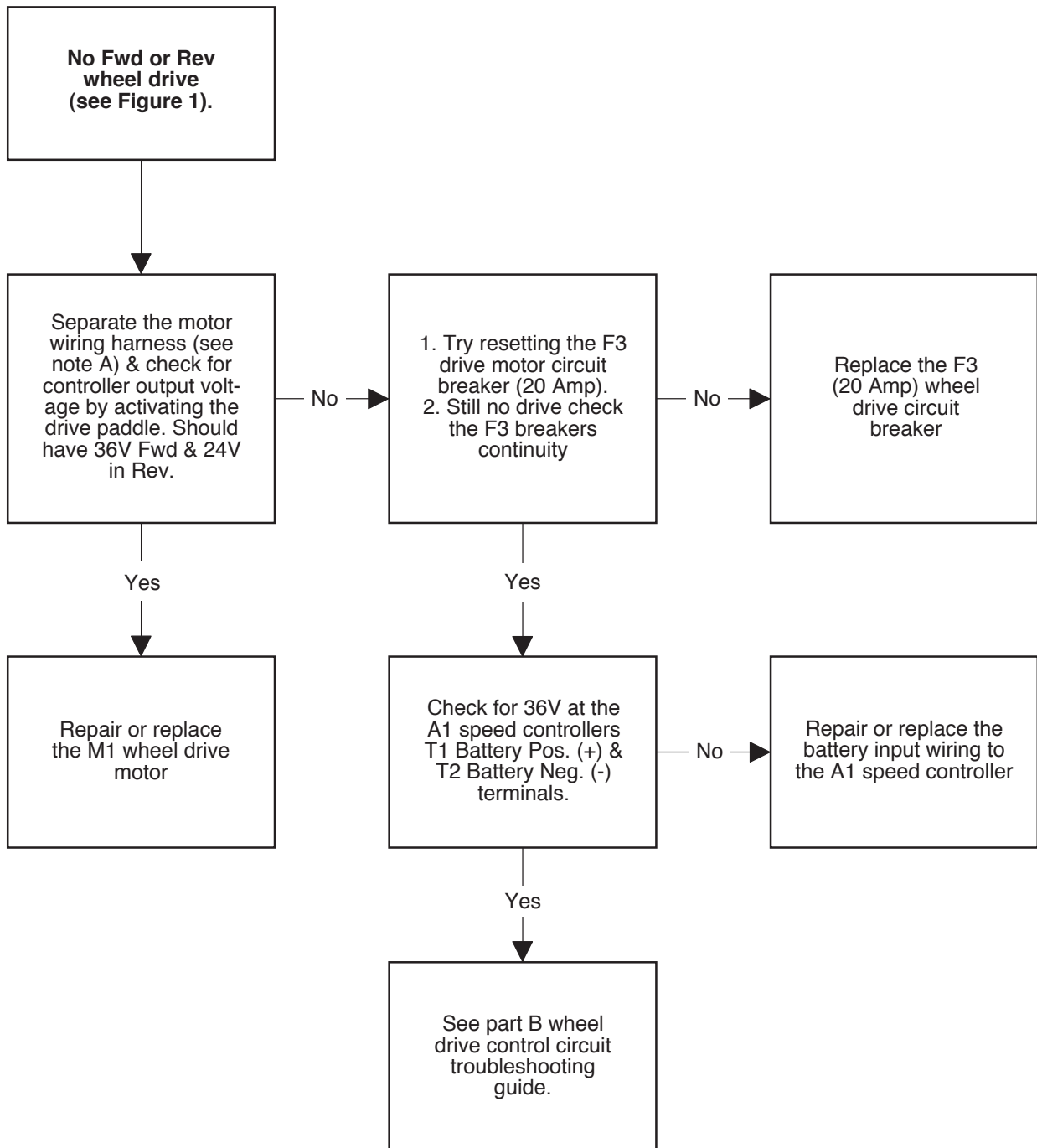

Note A: The drive wheel motor harness disconnect (wires Blu & Wht/Brn) is located in the lower rear of the machine frame in front of the right side caster wheel.

WHEEL DRIVE SYSTEM

TROUBLESHOOTING GUIDE ELECTRICAL (CONTINUED)

SYMPTOM ONE

Note: Do all testing with control panel R2 speed limiting pot in the maximum position, the drive wheel jacked up off the floor, key switch ON, and the drive paddle activated (pushed Fwd or pulled into Rev.)

Part B: Wheel drive system motor control circuit troubleshooting guide

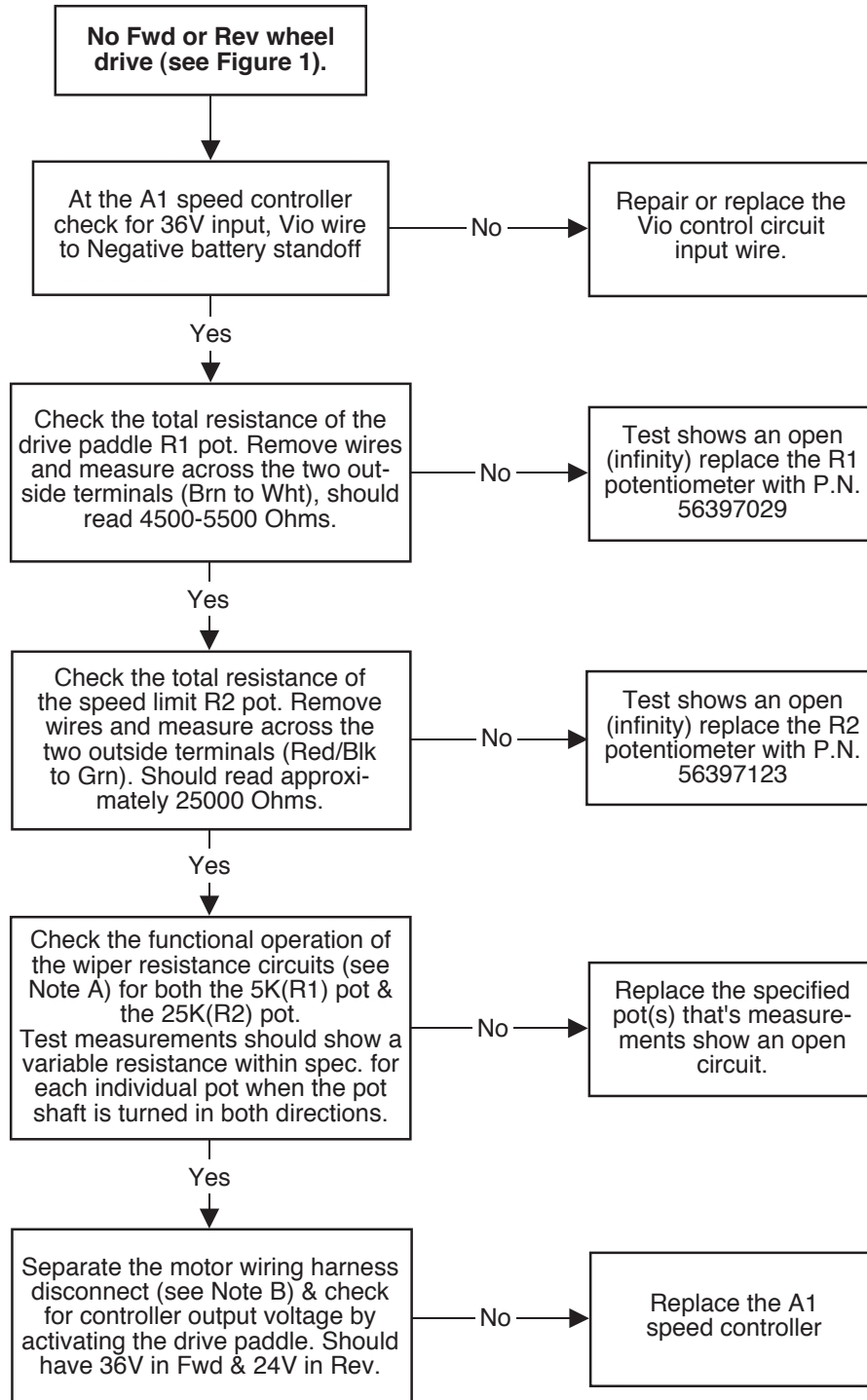

Note A: Follow the potentiometer test instructions shown in the Wheel Drive system section.

Note B: The drive wheel motor harness disconnect (wires Blu & Wht/Brn) is located in the lower rear of the machine frame in front of the right side caster wheel.

WHEEL DRIVE SYSTEM

CHAIN MAINTENANCE

- Every two months check the chain tension, 1/2 inch (13mm) deflection at mid point.
- Once a month check chain for binding and dryness, apply oil to lube the chain links.
- Yearly remove chain, clean and re-oil.

CHAIN REMOVAL AND ADJUSTMENT

Chain Removal:

WARNING!

Disconnect a battery cable at the battery pack before servicing.

- 1 See Figure 4. Loosen the Lock Nut **(A)** and back out Bolt **(B)** several turns to loosen the drive chain tension.
- 2 Remove the retainer clip from the chain's master link, separate and remove the chain from the sprockets.
- 3 To re-install chain loosen the (3) **(C)** drive motor mount screws and push the drive motor all the way forward. Note: The reason for this step is to shorten the distance between the sprockets to make it easier to reconnect the master link.
- 4 Install a new chain and reconnect the master link and tension chain. **Service Tip:** Attach a cable tie strap to the end of the chain to help guide it between the sprockets.

Adjustment:

- 1 Loosen the (3) motor mount Bolts **(C)** and the adjustment Lock Nut **(A)** to adjust chain tension.
- 2 Turn the Adjustment Bolt **(B)** in (CW) to obtain a 1/2 inch (13mm) chain deflection between the sprockets when moderate pressure is applied to the chain.
- 3 Tighten the adjustment bolt lock nut, the (3) motor mount bolts and test the drive system for proper operation.

WHEEL DRIVE MOTOR REMOVAL

- 1 Disconnect the drive motor wiring connector.
- 2 See Figure 4. Loosen the Lock Nut **(A)** and back out Bolt **(B)** several turns to loosen the drive chain tension.
- 3 Remove the retainer clip from the chain's master link, separate and remove the chain from the sprockets.
- 4 Remove both the Setscrews **(D)** and Hex Screw **(E)** from the Drive Motor Sprocket **(F)** then remove the sprocket from the motor shaft. **Note:** When reassembling, torque the Setscrews **(D)** to 80 in/lbs.
- 5 Support the Drive Motor **(G)** then remove the (3) motor mount Bolts **(C)** and remove the motor and Chain Tension Bracket **(H)** from the machine.
- 6 Follow steps 1-5 in reverse order to reassemble, then refer to the *Chain Adjustment* section to retension the chain.

DRIVE WHEEL REMOVAL

WARNING!

Never work under machine without safety stands or blocking to support the machine.

- 1 Block caster wheels and jack front of machine too where the drive wheel is 1-1/2 inches (38mm) off the floor. **Service Tip:** Place a small automotive type scissors or bottle jack underneath the front of tank bottom or metal frame support in the middle being careful not to damage any solution components.
- 2 Remove the drive chain (follow instructions in the *Chain Removal* manual section).
- 3 See Figure 4. Use a 10mm socket and wrench to remove the Hex Screws **(I)** and Nuts **(J)** that secure the Axle Retainer Bar **(K)** to the machine frame. Then slide the axle bar off the end of the Axle **(L)** to remove.
- 4 Pull the drive wheel assembly forward to remove the left side axle end from its side frame-mounting hole. Then maneuver the wheel assembly out from underneath the machine.
- 5 Follow steps 1-4 in reverse order to reassemble, then refer to the *Chain Adjustment* section to retension the chain.
- 6 Test-drive the machine for proper operation.

WHEEL DRIVE SYSTEM

FIGURE 4

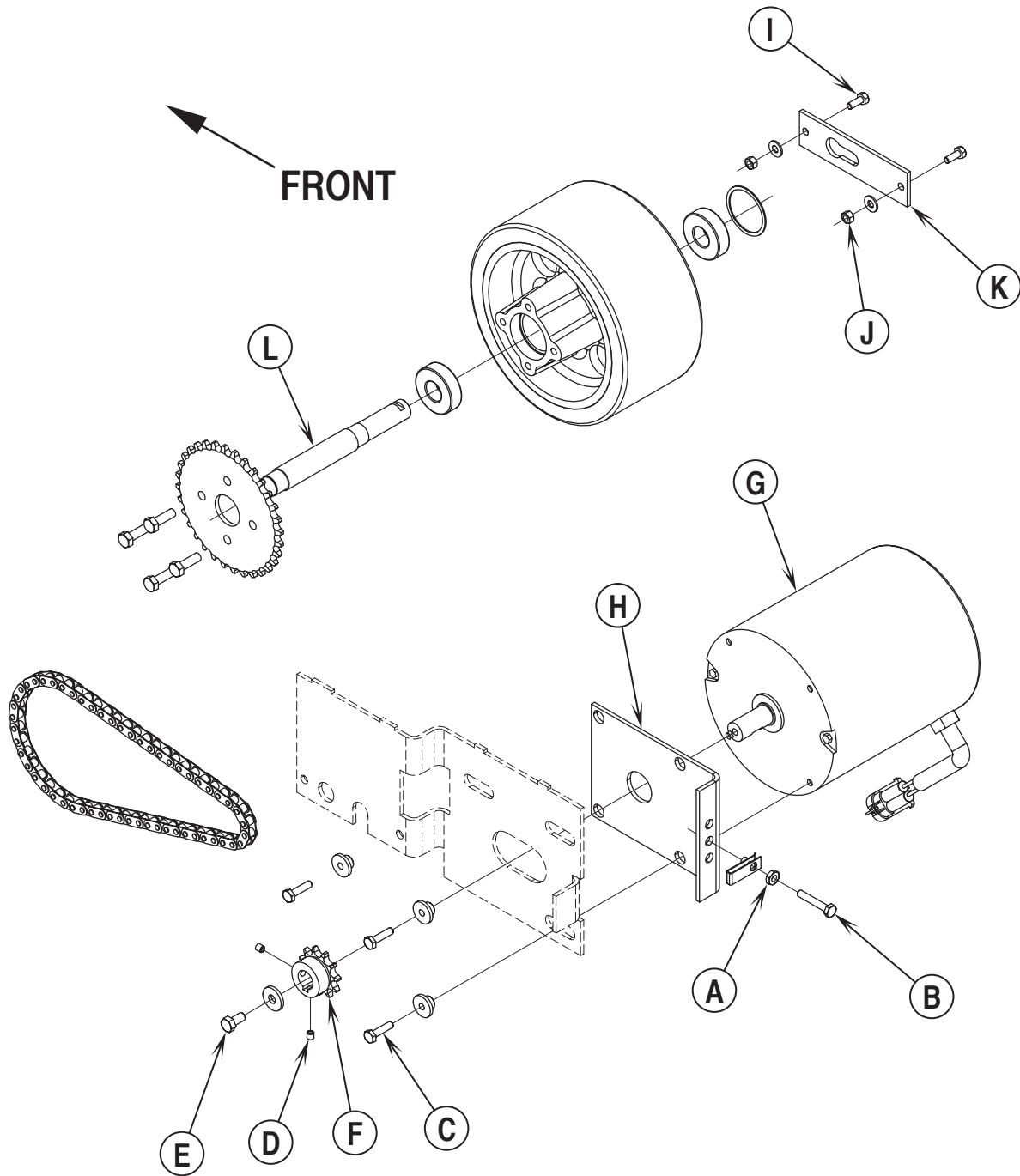

WHEEL DRIVE SYSTEM

5K POTENTIOMETER TESTING AND REMOVAL

⚠ WARNING!

Disconnect a battery cable at the battery pack before servicing.

Testing the 5K Potentiometer

Note: The potentiometer (pot) doesn't have to be removed from its housing mount to test.

- 1 See Figure 5. Remove the front drive paddle Cover (M) from the rear Cover (N) held together with (4) item (O) Screws.
- 2 See inset of Figure 6. Observe the 3 wires connected to the pot and disconnect. Note the proper wire numbers and their terminal connections for re-assembly.
- 3 Test the Pot (P) using an ohmmeter, the potentiometer specification is 5K Ohms. Connect the meter leads to each of the outside terminals (1 high & 3 low) on the pot, it should read approximately 5000 ohms (range 4500-5500 ohms).
- 4 Next, take the 1 high pot test lead and connect to the middle terminal (2 wiper), then push and pull the rear cover to turn the shaft in both directions. The readings should be approximately half the total resistance (2500 ohms) towards 5000 ohms and 2500 ohms towards 0 ohms. Example "A" total resistance of pot 4840 ohms (1 high/3 low) test terminals. Example "B" test middle connection (2 wiper) and outside rear (3 low) Fwd reading 2420 ohms to 4700 ohms, Rev 2420 ohms to 430 ohms.
- 5 Testing Summary: The above tests are to show the increase and decrease of the pot through its working range. If you do not get similar readings replace the Potentiometer (P).

Potentiometer Removal

- 6 See Figure 6. Loosen the pot shaft anchor nut and unthread it to the end of the shaft.
- 7 Back out the Screw (Q) from the pot Fork (R).
- 8 Maneuver the pot out from its mounting bracket hole and separate the Fork (R) from the shaft end.
- 9 Finish unthreading the anchor nut from the end of the pot and then remove the pot completely from the handle mount.
- 10 To reinstall a potentiometer see the *5K Potentiometer Installation and Adjustment* section in this manual.

FIGURE 5

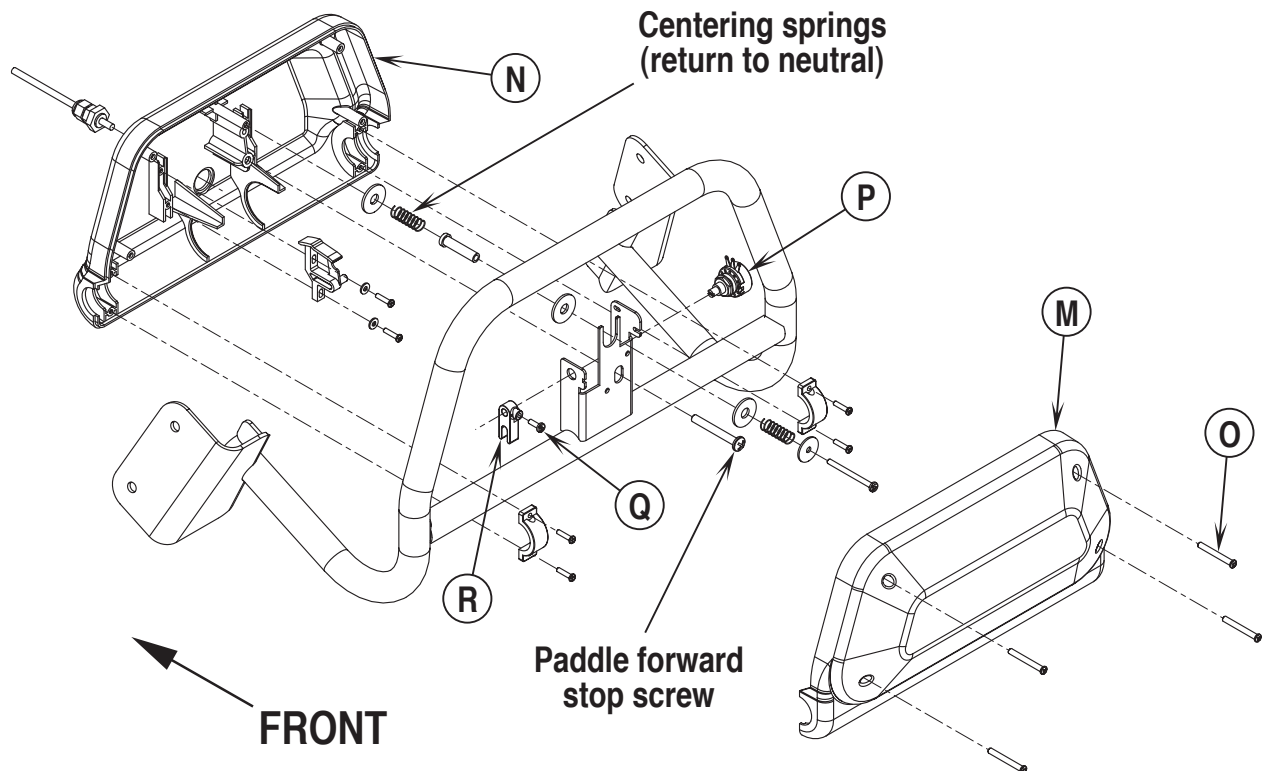

WHEEL DRIVE SYSTEM

5K POTENTIOMETER INSTALLATION AND ADJUSTMENT

⚠ WARNING!

Disconnect a battery cable at the battery pack before servicing.

⚠ WARNING! Operator Safety Hazard

The adjustment of the potentiometer is to set the drive paddle for a neutral drive motor operation. If the potentiometer is not adjusted properly the machine could move in either forward or reverse without any operator input.

- 1 See Figure 6. Install the pot and washer into the handle mount hole, then tighten the anchor nut.
- 2 Install the Fork (**R**) on the end of the pot shaft and paddle bracket Drive Pin (**S**) as shown. Note: Do not tighten the fork/shaft Set Screw (**Q**) at this time.
- 3 Using an ohmmeter connect test leads to the pot wiper terminal #2 and pot low terminal #3. Then adjust (turn) pot shaft to obtain half of the R1's total resistance. Service Tip: Use a small screwdriver inserted into the end of the fork housing to easily turn the slotted shaft end.
- 4 Next tighten the (**Q**) Set Screw, being careful not to turn the shaft. Install the pot wires (three black #'s 1, 2, & 3) as shown below.
- 5 Reconnect the battery cable and turn the key switch on and test the drive system for proper Neutral, Forward and Reverse operations. Note: The dash mounted Speed Control Knob (**9**) should be turned to its Max. speed setting.

FIGURE 6

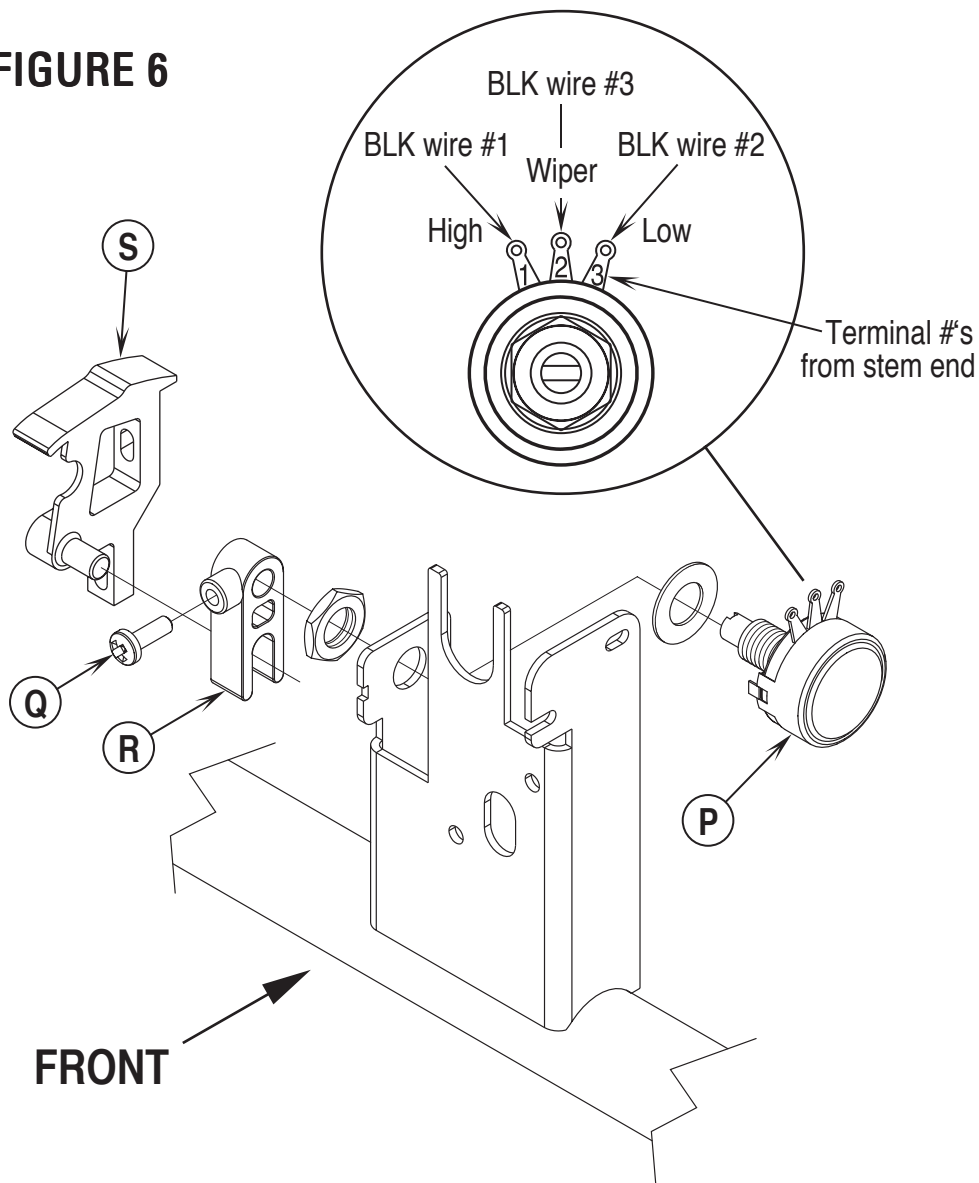

WHEEL DRIVE SYSTEM

25K WHEEL DRIVE SPEED LIMIT POTENTIOMETER TESTING

⚠ WARNING!

Disconnect a battery cable at the battery pack before servicing.

Testing the 25K Potentiometer

Note: The potentiometer (pot) doesn't have to be removed from the instrument panel to test.

- 1 See Figure 7. Remove the instrument panel, to access the Speed Adjustment Pot (**T**), secured with (4) item (**U**) Screws as shown.
- 2 Observe the wires connected to the pot and disconnect all three. Note the proper wire colors and their correct terminal connections to re-assemble.
- 3 Test the Potentiometer (**T**) using an ohmmeter, the specification is 25000 ohms. Connect the meter leads to each of the outside connections on the potentiometer, should read approximately 25000 ohms. Next, take one of the test leads and connect to the middle terminal, then turn the stem both directions. The resistance value will change (vary) increasing and decreasing through its full range of 0-25000 ohms and 25000-0 ohms approximately. If you do not get these readings replace the potentiometer.

FIGURE 7

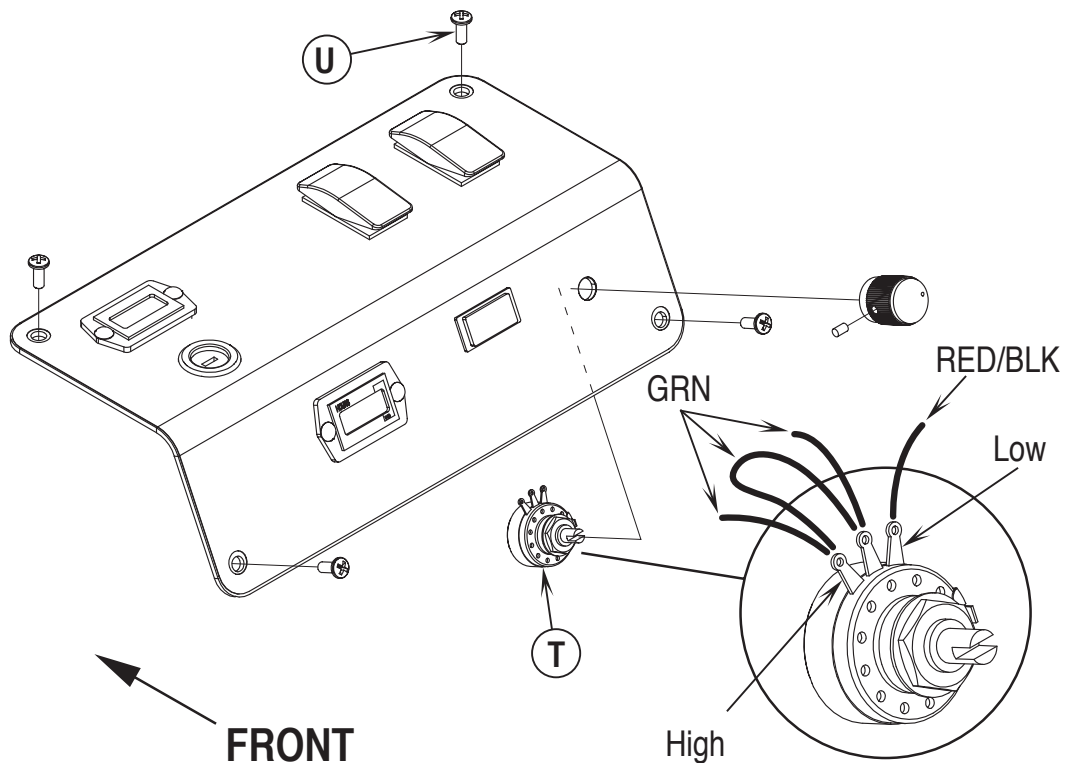

WHEEL DRIVE SYSTEM

DIRECTION SWITCH S6 INSTALLATION & ADJUSTMENT

- 1 See Figure 8. Loosely install the S6 switch to its paddle mount holes.
- 2 Loosen the (2) screws securing the Cam Controller (V).
- 3 Make rough switch adjustment by moving the switch in or out and the cam controller up or down to position the switch arm and cam ramp angle as shown. Then tighten the switch mount screws.
- 4 Make the final switch adjustment by moving the cam controller up to where you hear the switch click (switch arm compressed) then pull the cam down just enough to where it un-clicks (arm is not compressed) then tighten the cam controller screws. Note: The correct switch installation is where the switch arm is not compressed and is in its normally closed position.
- 5 To test the normal closed (NC) switch function connect an ohmmeter to the Com and NC switch terminals. You should read continuity when the drive paddle is in neutral or forward. To test the normal open (NO) switch function connect the ohmmeter leads to the Com and NO switch terminals. You should read continuity when the drive paddle is moved into reverse.

FIGURE 8

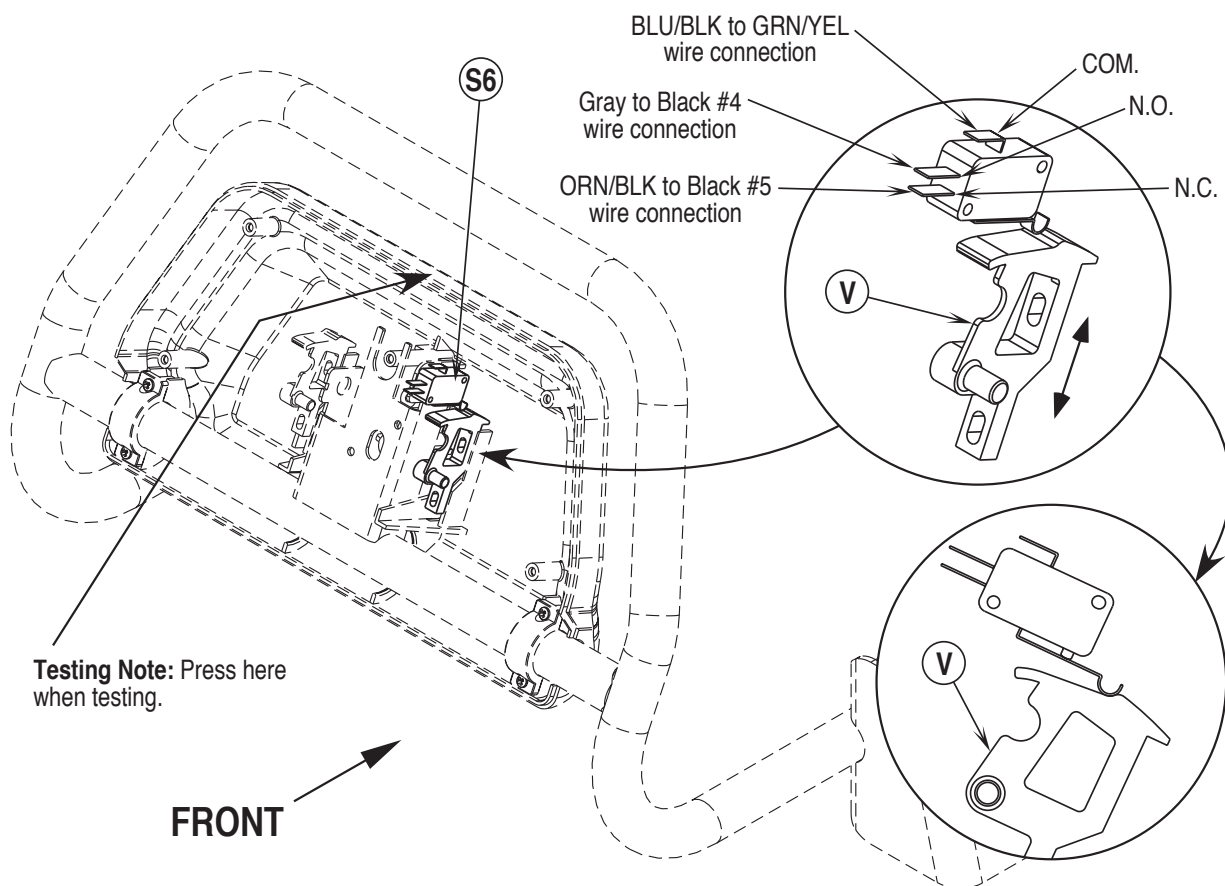

ELECTRICAL SYSTEM

RECOMMENDED BATTERIES AND CHARGERS

	Qty	Description	Weight	Length	Width	Height
	6	Battery, 195AH @ 20hr, 6V	59 lbs.	10.25"	7.08"	10.88"
Standard	6	Battery, 238AH @ 20hr, 6V	66 lbs.	10.25"	7.08"	10.88"
	1	Automatic Battery Charger, 36VDC-20 Amp (120V, 60Hz)				

INSTALL THE BATTERIES

⚠ WARNING!

Use extreme caution when working with batteries. Sulfuric acid in batteries can cause severe injury if allowed to contact the skin or eyes. Explosive hydrogen gas is vented from inside the batteries through openings in the battery caps. This gas can be ignited by any electrical arc, spark or flame.

When Servicing Batteries...

- Remove all jewelry.
- Do not smoke.
- Wear chemical goggles, rubber gloves and a protective apron.
- Work in a well-ventilated area.
- Do not allow tools to touch more than one battery terminal at a time.

⚠ CAUTION!

Electrical components in this machine can be severely damaged if the batteries are not installed and connected properly. Batteries should be installed by Nilfisk-Advance or by a qualified electrician.

- 1 Remove the batteries from their shipping crate and carefully inspect them for cracks or other damage. If damage is evident, contact the carrier that delivered them or the battery manufacturer to file a damage claim.
- 2 Turn the Master Key Switch **(4)** OFF and remove the key.
- 3 Tip the recovery tank to the side, locked position. Remove the battery cables from inside the battery compartment.
- 4 Your machine comes from the factory with enough battery cables to install six (6 volt), 238 Amp hour batteries. Carefully lift the batteries into the battery compartment and arrange them exactly as shown.
- 5 The terminals on the battery cables are marked "+" for positive and "-" for negative. Install the battery cables as shown, with the terminals marked "+" on the positive battery terminals and the terminals marked "-" on the negative terminals. Position the cables so the battery caps can be easily removed for battery service.
- 6 Carefully tighten the nut in each battery terminal until the terminal will not turn on the battery post. Then tighten the nut an additional 1/2 turn. Do not over-tighten the terminals, or they will be very difficult to remove for future service.
- 7 Coat the terminals and posts with spray-on battery terminal coating (available at most auto parts stores).
- 8 Put one of the black rubber boots over each of the terminals.

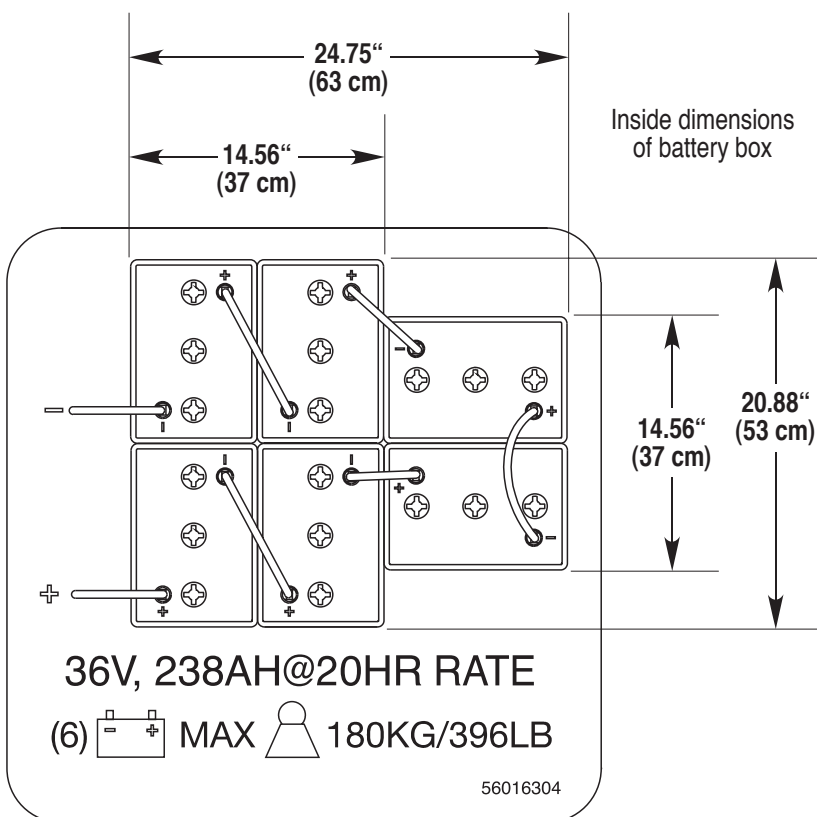

FIGURE 1

ELECTRICAL SYSTEM

DESCRIPTION OF THE BATTERY LOW VOLTAGE CUTOUT FEATURE

The model discussed in this manual is equipped with a low voltage cutout feature to prevent over-discharging of the batteries. When a machine's battery pack voltage falls below specifically defined thresholds (voltage settings) the scrub, solution and vacuum systems are automatically shut down. The standard lead acid battery (wet cell) setting is 1.75V per cell.

LOW VOLTAGE CUTOUT MODULE FUNCTION

Special Operational Note: This machine uses a special low voltage cutout system to help prolong battery life. The brush motor, solution pump and vacuum motors will turn off automatically and cease to function when the batteries reach an 80% depth of discharge. The discharge value of 80% is 31.5 volts (1.75V per cell). The machine's control panel mounted battery fuel gauge (P3) will double flash to notify the operator that the battery pack is at an 80% depth of discharge and all the above machine functions will stop running. Note: The voltage cutout function doesn't affect the operation of the wheel drive motor. All the machine systems will return to normal when the battery pack is recharged.

Explanation of the component functions used in the low voltage cutout system.

See Figure 2. The battery fuel gauge (P3) terminals 1 & 2 (pos. & neg.) are wired direct to the battery pack and monitors (reads) its changing voltage condition. Terminal #4 is a positive input from the key switch (S2) that causes the gauge to turn on its display (LED lights). This shows the battery pack's condition state of discharge to the operator. The terminal #3 deep discharge signal output +5 volts (operational) and 0 volts (battery discharged/cutout) turns ON or OFF the K5 low voltage relay module. The Org wire is a 1.5Amp fused (pos.) load voltage input to K5. When battery pack voltage is sensed above 31.5 volts P3's #3 (Wht wire) output is 5 volts and it energizes the K5 relay coil (Blk & Red wires). This outputs 36 volts to the (S1) brush switch (Yel wire). This allows all the down stream control circuits to function brush, solution and vacuum ON. A voltage of less than 31.5 volts at P3 and the #3 output is 0 volts and the K5 coil is de-energized. This opens the output to the S1 switch and all the circuit functions brush, solution and vacuum are turned OFF.

DESCRIPTION OF THE BATTERY FUEL GAUGE

See Figure 3. The Battery Fuel Gauge (3) uses a 10 bar LED display that indicates the state of the batteries charge, successively, bar by bar, from full to empty. At 70% depth of discharge a single flashing light signals an energy reserve alert. At 80% of discharge, a double flashing light signals an empty alarm. The battery gauge will retain the last state-of-charge condition even when the machine has been turned off. The battery fuel gauge state-of-charge display indication is automatically reset to full charge when the battery pack is recharged.

FIGURE 2

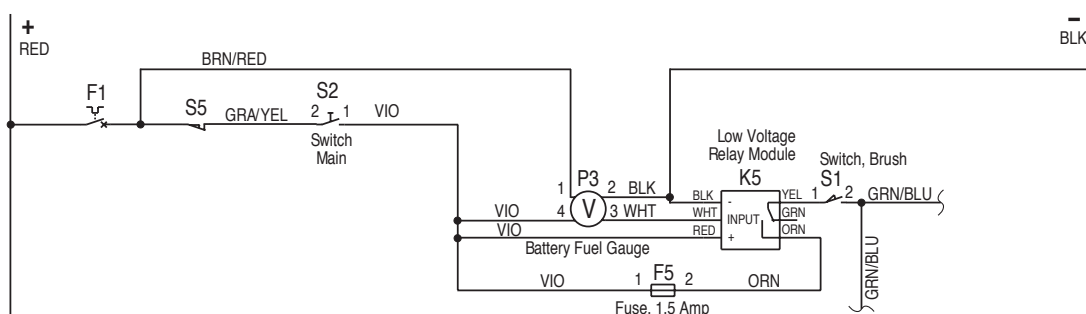

ELECTRICAL SYSTEM

CHARGING THE BATTERIES

Charge the batteries each time the machine is used, or whenever the Battery Fuel Gauge **(3)** shows a double flashing red LED indicator. Note: The machine also uses a special low voltage cutout that inhibits the scrub, solution and vacuum systems, see in this manual section the description for the low voltage cutout feature.

To Charge the Batteries...

- 1 Push the connector from the charger into the machine Battery Charger Connector port **(16)** located on the rear electrical panel.
- 2 Follow the instructions on the battery charger.
- 3 Check the fluid level in all the battery cells **after** charging the batteries. Add distilled water, if necessary, to bring the fluid level up to the bottom of each battery cell's filler tube.

WARNING!

Do not fill the batteries before charging.
Only charge batteries in a well-ventilated area.
Do not smoke while servicing the batteries.

CAUTION!

To avoid damage to floor surfaces, always wipe water and acid from the top of the batteries after charging.

FIGURE 3

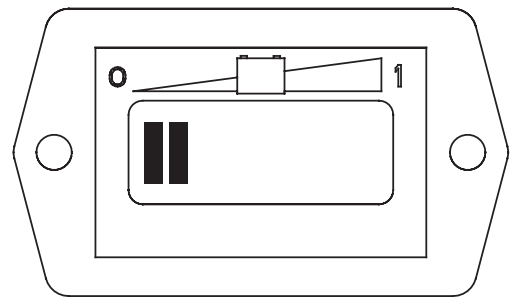

P3

BATTERY MAINTENANCE

Proper maintenance of electric vehicle batteries can greatly extend their life. Well-maintained batteries may last up to 3 years, but failure after 1 year is common if maintenance has been poor.

There are 3 simple rules for good battery maintenance:

- **Maintain Proper Electrolyte Level** - Use distilled water in batteries whenever possible. If batteries are discharged, add just enough water to cover the plates in each cell. If batteries are fully charged, fill each cell to the bottom of the filler tube. **Do not over-fill the batteries! Do not add acid to batteries!**
- **Keep the Batteries Charged** - Batteries should be charged each time that a machine is used for more than one hour. Machine operators should open the battery compartment cover for charging, to avoid a concentrated build-up of hydrogen gas. Operators should follow the instructions provided with their specific battery charger, to determine how long the batteries should be charged. Even when a machine is stored, the batteries should be charged once a month to prevent the batteries from "sulfating". Almost all battery caps are vented, so there's no need to loosen or remove them for charging.
- **Keep the Batteries Clean** - Use a damp cloth to wipe dirt from the top of the batteries. Battery terminals must be clean and tight. If the tops of the batteries are wet after charging, the batteries have probably been over-filled or over-charged. Note: If there is acid on the batteries, wash the tops of the batteries with a solution of baking soda and water (2) tablespoons of baking soda to 1 quart of water.

BATTERY TESTING

A battery problem is usually recognized by the machine operator, as a decrease in the machine's running time. This condition is usually caused by one (or more) "dead cell" in the battery system- that is, one (or more) cell that is putting out less voltage than the other cells.

Note: Always charge batteries before testing.

There are 2 ways to find a dead cell:

- Use a hydrometer to check the specific gravity (or "state of charge") of the fluid in each cell. A dead cell is one that reads 50 points (or more) lower than the other cells.
- Use a volt meter to check the voltage of each battery with the vacuum and brush drive motors running. The battery with the dead cell will read 1 or 2 volts lower than the other batteries in the system.

If the batteries in the machine are more than 1 year old, it's usually best to replace the whole set, rather than replacing just one battery.

ELECTRICAL SYSTEM

FIGURE 4

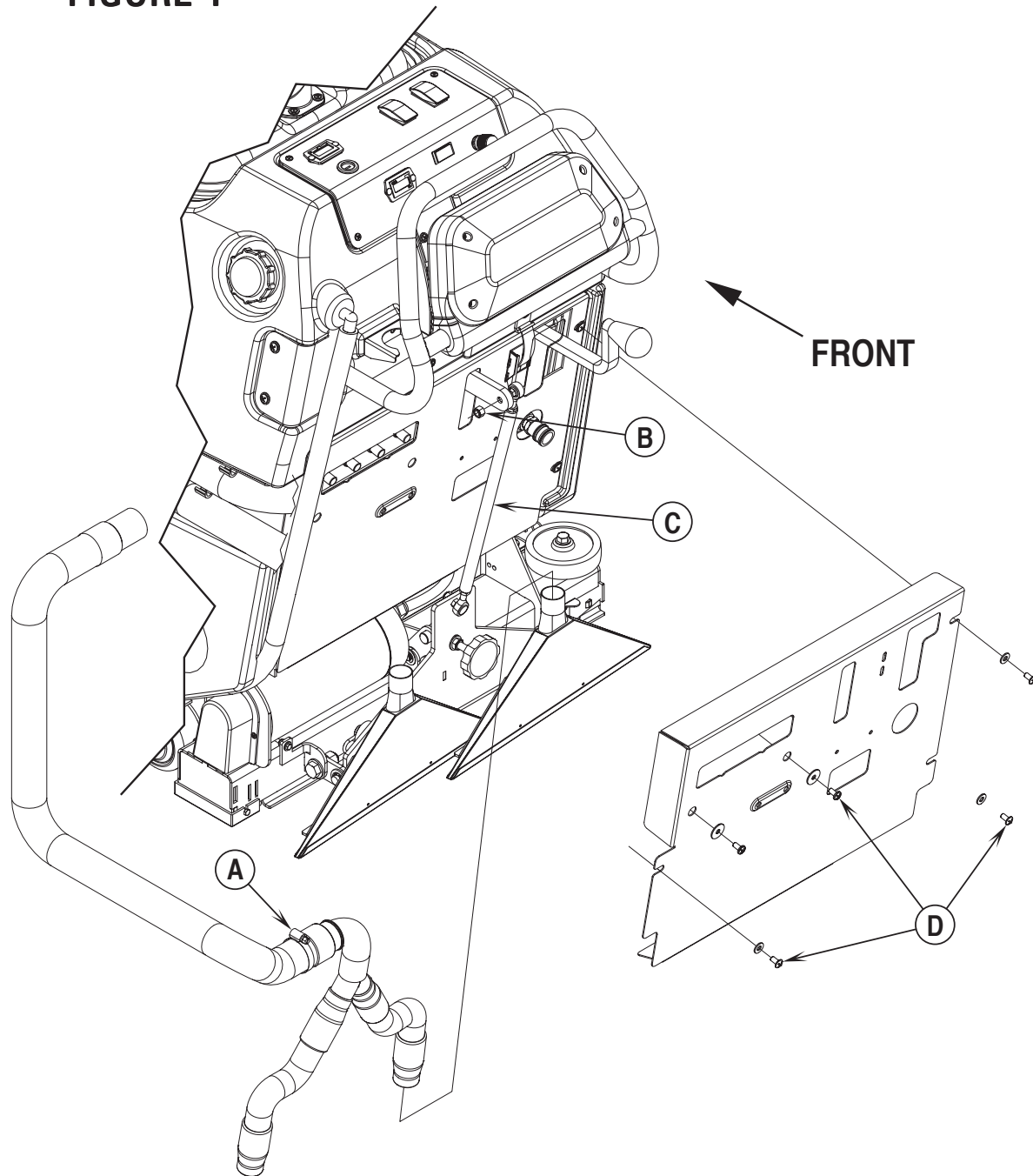

REMOVAL OF ELECTRICAL PANEL LOWER CHASSIS

- 1 Drain the upper solution tank, unlatch the tank support and swing open. Then disconnect one of the battery cables.
- 2 Unhook the recovery tank drain hose from its storage location and lay it to the side.
- 3 See Figure 4. Loosen Hose Clamp **(A)** securing the main waste water return hose at the Y fitting and then pull all (3) hoses off.
- 4 From the top of the brush housing lift linkage remove the Hex Nut **(B)** and separate then swing the Lift Rod **(C)** down and to the side.
- 5 Remove the (5) panel Screws **(D)** as shown. Then pull the panel cover up and to the rear guiding the brush lever knob through the opening to completely remove it from the chassis.

ELECTRICAL SYSTEM

COMPONENT LOCATION

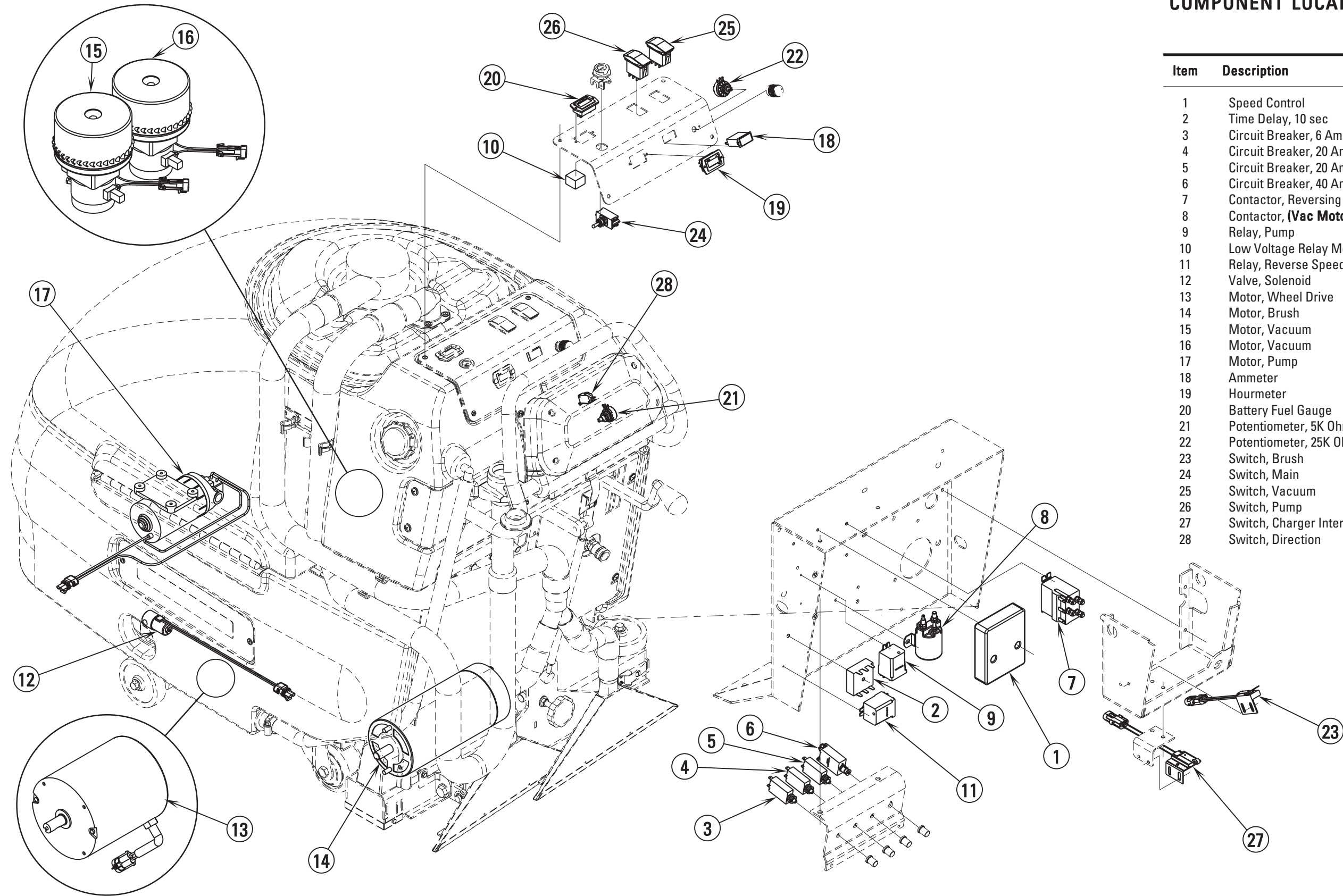

Item	Description
1	Speed Control
2	Time Delay, 10 sec
3	Circuit Breaker, 6 Amp (Controls)
4	Circuit Breaker, 20 Amp (Brush Motor)
5	Circuit Breaker, 20 Amp (Drive)
6	Circuit Breaker, 40 Amp (Vac Motor)
7	Contactor, Reversing (Brush)
8	Contactor, (Vac Motor)
9	Relay, Pump
10	Low Voltage Relay Module
11	Relay, Reverse Speed Limit
12	Valve, Solenoid
13	Motor, Wheel Drive
14	Motor, Brush
15	Motor, Vacuum
16	Motor, Vacuum
17	Motor, Pump
18	Ammeter
19	Hourmeter
20	Battery Fuel Gauge
21	Potentiometer, 5K Ohm (Throttle)
22	Potentiometer, 25K Ohm (Speed Limit)
23	Switch, Brush
24	Switch, Main
25	Switch, Vacuum
26	Switch, Pump
27	Switch, Charger Interlock
28	Switch, Direction

ELECTRICAL SYSTEM

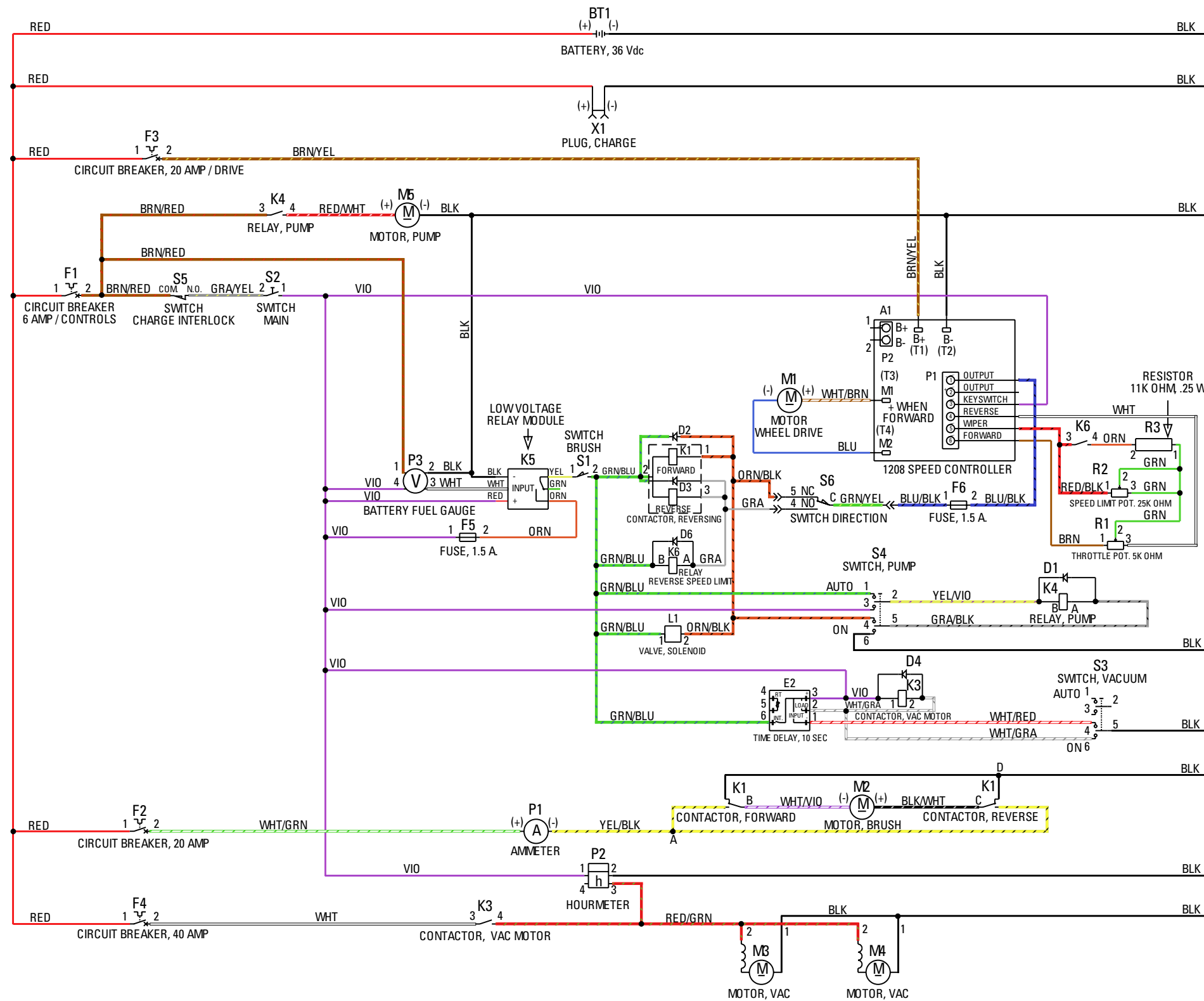

WIRING DIAGRAM / SCHEMATIC

Item	Qty	Description
A1	1	Speed Controller
BT	1	36Vdc Battery
D1	1	Diode
D2	1	Diode
D3	1	Diode
D4	1	Diode
D5	1	Diode
D6	1	Diode
E2	1	Time Delay, 10 sec
F1	1	Circuit Breaker, 6 Amp (Control Circuit)
F2	1	Circuit Breaker, 20 Amp (Brush Motor)
F3	1	Circuit Breaker, 20 Amp (Drive)
F4	1	Circuit Breaker, 40 Amp (Vacuum Motor)
F5	1	Fuse, 1.5 Amp
F6	1	Fuse, 1.5 Amp
K1	1	Contactor, Reversing (Brush)
K3	1	Contactor, Vac Motor
K4	1	Relay, Pump
K5	1	Low Voltage Relay Module
K6	1	Relay, Reverse Speed Limit
L1	1	Solenoid Valve
M1	1	Motor, Wheel Drive
M2	1	Motor, Brush
M3	1	Vacuum Motor
M4	1	Vacuum Motor
M5	1	Motor, Pump
P1	1	Ammeter
P2	1	Hourmeter
P3	1	Battery Fuel Gauge
R1	1	Potentiometer, 5K Ohm (Throttle)
R2	1	Potentiometer, 25K Ohm (Speed Limit)
R3	1	Resistor, 11K Ohm
S1	1	Switch, Brush
S2	1	Switch, Main
S3	1	Switch, Vacuum
S4	1	Switch, Pump
S5	1	Switch, Charger Interlock
S6	1	Switch, Direction
X1	1	Plug, Charge

ELECTRICAL SYSTEM

WIRING DIAGRAM / SCHEMATIC

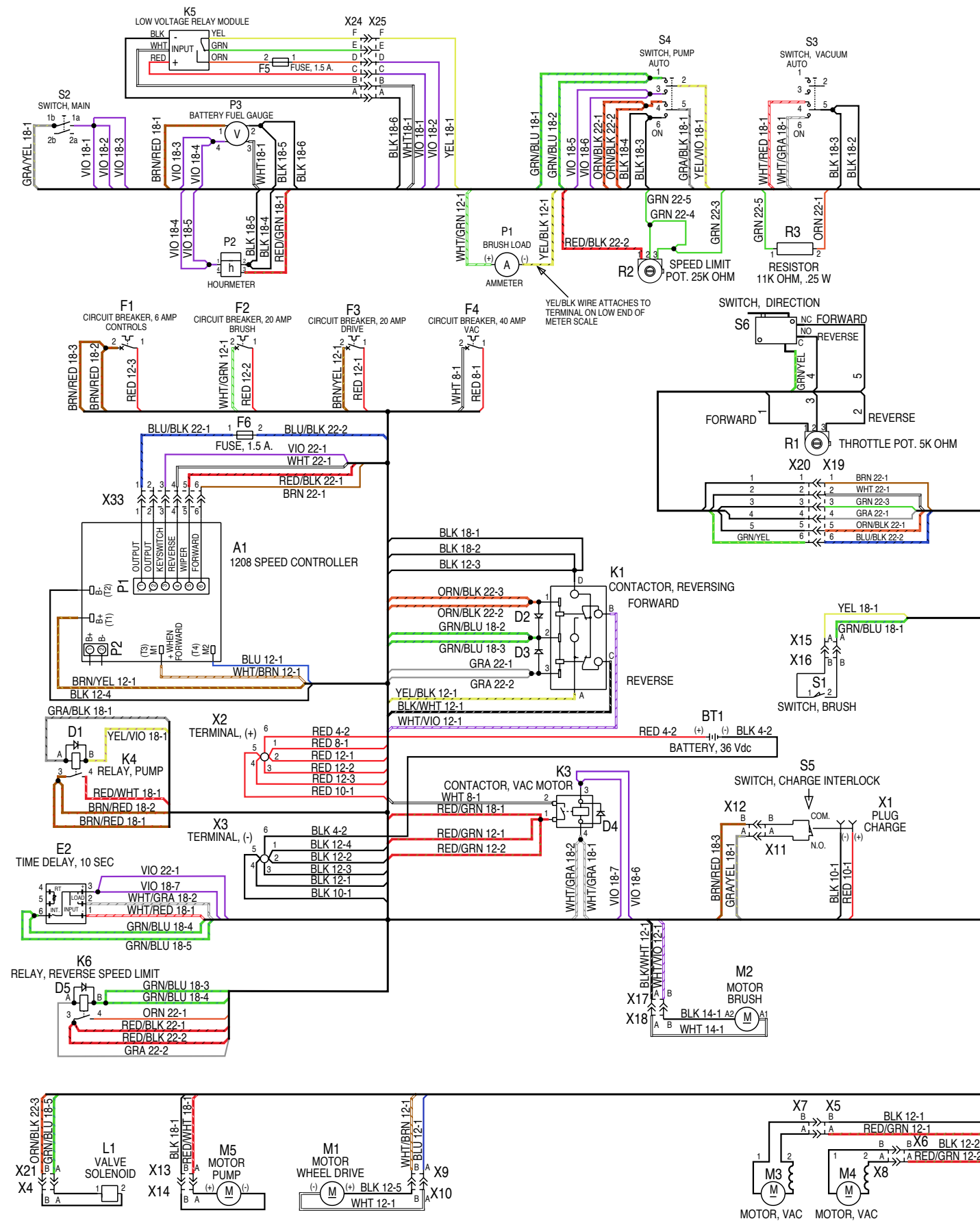

DANMARK

Nilfisk-Advance Nordic A/S
Sognevej 25 - Box 344
DK-2605 Broendby
☎ 43 23 83 50 – Fax 43 42 15 95

NORGE

Nilfisk-Advance AS
Enebakkvn, 119, 0680 Oslo, Postboks 196, Manglerud,
0612 Oslo
☎ 22 08 63 50 – Fax 22 08 63 63
Distriktsrepresentanter over hele landet

SVERIGE

Nilfisk-Advance AB
Sjöbjörnsvägen 5, 117 67 Stockholm
☎ 085 55 944 00 – Fax 085 55 944 30

FINLAND/ SUOMI

BERNER Ltd. Facotek Department
Etäleranta 4B, 00130 Helsinki
☎ +358 9 1345 1382

AUSTRALIA

Nilfisk-Advance Pty. Ltd.
48 Egerton Street
Silverwater NSW 2128
☎ (02) 8748 5905 – Fax (02) 9648 2711
Customer Responce Centre:
☎ 1 800 011 013

BELGIQUE / BELGIË/ LUXEMBOURG

Nilfisk-Advance s.a./n.v.
Doornveld/ Sphere Business Park
Industrie Asse 3, nr 11 – bus 41
1731 Zellik-Asse
☎ (02) 467.60.50 Fax (02) 463.44.16

CANADA

Nilfisk-Advance Ltd.
396 Watline Avenue
Mississauga, Ontario L4Z 1X
☎ (905) 712-3260 – Fax (905) 712-3255

DEUTSCHLAND

Nilfisk-Advance AG
Siemensstraße 25-27
25462 Rellingen
☎ (041 01) 3990 – Fax (04101) 399191
Zentraler Kundenservice
☎ für die Industrie: 0180 535 67 97
☎ Institutionen und Gebäudereiniger: 0180 500 11 70

FRANCE

Nilfisk-Advance S.A.
BP 246
91944 Courtaboeuf Cedex
☎ (01) 69.59.87.00 Télécopie (01) 69.59.87.01

HONG KONG

Nilfisk-Advance Ltd.
2001, 20/F HK Worsted Mills
Industrial Building
31-39 Wo Tong Tsui Street
Kwai Chung, N.T.
☎ 2427 59 51 – Fax 2487 5828

IRELAND

Nilfisk-Advance Ltd.
28 Sandford Office Park
Dublin 18
☎ +353 1 2943838 – Fax +353 1 2943845

JAPAN

Nilfisk-Advance Inc.
3-4-9 Chigasaki Minami
Tsuzuki-Ku Yokohama 224 0037
☎ 045-942-7741 – Fax 045-942-6545

MALAYSIA

Nilfisk-Advance Sdn Bhd
Lot 2, 1st. Floor
Lorong 19/1A
46300 Petaling Jaya
Selangor Darul Ehsan
☎ 03-7568188/03-7568189/03-7568388 – Fax 03-7566828

NEDERLAND

Nilfisk-Advance B.V.
Flevolaan 7, Postbus 341
1380 AH Weesp
☎ 0294-462121 – Fax 0294-430053

NEW ZEALAND

Nilfisk-Advance Limited
477 Great South Road, Penrose
Auckland
☎ (09) 525 0092 – Fax (09) 525 6440

SCHWEIZ / SUISSE

Nilfisk-Advance AG
Ringstrasse 19, 9533 Kirchberg/Wil
☎ 719 23 52 83 – Fax 719 23 84 44

SINGAPORE

Nilfisk-Advance Pte. Ltd.
22, Woodlands Industrial Park E1
Singapore 757740
☎ (65) 759 9100 – Fax (65) 759 9133

TAIWAN

Nilfisk-Advance Ltd.
1 F, No.23, Lane 132, Sec. 2
Ta An Road, Taipei
☎ 700 22 68 – Fax 784 08 43

UNITED KINGDOM

Nilfisk-Advance Limited
Newmarket Road
Bury St. Edmunds
Suffolk IP 33 3SR
☎ (01284) 763163 – Fax (01284) 750562

USA

Nilfisk-Advance Inc.
14600 21st Avenue North
Plymouth, MN 55447-3408
☎ +1 800 989 2235 – Fax 1 800 989 6566

Nilfisk-Advance of America, Inc.
300 Technology Drive
Malvern, PA 19355
☎ (610) 647 647-6427

ÖSTERREICH

Nilfisk-Advance GmbH
Vorarlberg Allee 46
1230 Wien
☎ 1 616 58 30 – Fax 1 616 58 30 40

ESPAÑA

Nilfisk-Advance, S.A.
Torre D'Ara
Passeig del Rengle, 5 Pl.9-10
E-08302 – Mataró (Barcelona)
☎ Tel. 93 741 24 00 – Fax: 93 757 80 20
Central atención al cliente: 902 200 201
nilfisk@nilfisk-advance.es – www.nilfisk-advance.com
Distribuidores y Servicio Técnico en toda España y Andorra

ITALIA

Nilfisk-Advance Italia Spa
Località Novella Terza
26862 Guardamiglio (LO)
Italy
☎ +39 0377 414067-54 – Fax +39 0377 414097
www.nilfisk-advance.com

PORTUGAL

Nilfisk-Advance Lda.
Rua Cândido de Figueiredo, 91-i, 1500-133 LISBOA
☎ 01/7784142 – Fax 01/7785613
Porto 02/526766 – Fax 02/520739
Açores 096/628092/3 – Fax 096/628129
Madeira 091/228965 – Fax 091/228796

GREECE

Embiom S.A.
Λεωφ. Βουλιαγμένης 60
Αργυρούπολη
164 52 Αθήνα
☎ 9950613 - Fax 9951680

